

TECHNICAL CATALOGUE

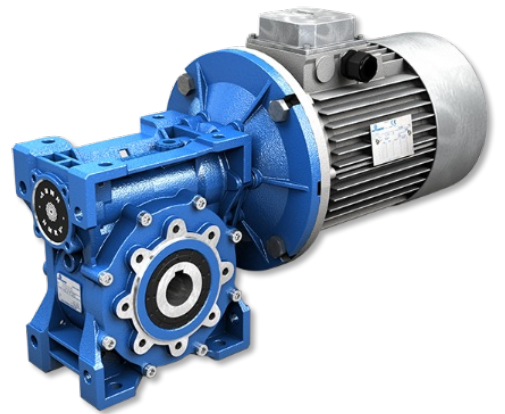

WORM GEARED MOTORS

STANDARD **IEC**
DIRECTIVE **ATEX** 

1. GENERAL INFORMATION

1.1	COMPANY PROFILE	4
1.2	PRODUCTS AND SOFTWARE MOTOVARIO	6
1.3	ATEX	9
1.4	SYMBOLS AND FORMULAS	10
1.4.1	Symbols	10
1.4.2	Formulas	11
1.5	PRODUCT SELECTION	12
1.5.1	Product selection	12
1.6	SERVICE FACTOR	13
1.7	INSTALLATION	14

2. PRODUCT INFORMATION

2.1	DESIGN FEATURES	15
2.2	TYOLOGY	16
2.2.1	Designation	16
2.2.2	Versions	19
2.2.3	Modularity	21
2.3	MOUNTING POSITIONS	23
2.3.1	Mounting positions	23
2.3.2	Position of terminal box	25
2.4	EFFICIENCY	26
2.4.1	Efficiency	26
2.4.2	Irreversibility	26
2.5	MESH DATA	27
2.6	ANGULAR BACKLASH	28
2.7	DIRECTION OF ROTATION	29
2.8	CRITICAL APPLICATIONS	30
2.8.1	Critical applications	30
2.8.2	Information	30
2.9	MOTOR FLANGE AVAILABILITY	31
2.9.1	NMRV - NMRV-P Motor flange availability	31

2.9.2	NMRV - NMRV-P HYBRID Motor flange availability	32
2.9.3	HA31+NMRV Motor flange availability	33
2.9.4	NMRV-P/HW Motor flange availability	34
2.9.5	Ratios NRV/NMRV/NMRV-P+NMRV/NMRV-P	35
2.10	OUTPUT SHAFT BEARINGS	37
2.11	OVERHUNG LOAD	38
2.11.1	Information	38
2.11.2	Input	38
2.11.3	Output	39
2.12	LUBRICATION	40
2.12.1	Information	40
2.12.2	Lubricants	40
2.12.3	Special lubricants	41
2.12.4	Quantity	42
2.13	MOMENTS OF INERTIA	43

3. DIMENSIONS

3.1	REDUCERS/GEARED MOTORS	44
3.1.1	NMRV 025	44
3.1.2	NMRV 030-150	45
3.1.3	NRV	46
3.1.4	HA31+NMRV	47
3.1.5	NMRV-P/HW	47
3.1.6	NMRV-P/IHW	49
3.1.7	NMRV/NMRV-P+NMRV/NMRV-P	50
3.1.8	NRV/NRV-P+NMRV/NMRV-P	51
3.2	WEIGHTS	52
3.3	SHAFT END	53
3.4	ELECTRIC MOTORS	54
3.4.1	Electric motors	54
3.4.2	Standard high efficiency (TS), high (TH) and premium (TP) motors	56
3.4.3	Nominal power - [kW]	56

4. ACCESSORIES AND OPTIONS

4.1	LOW SPEED SHAFTS	57
4.2	OUTPUT FLANGE	58
4.3	SHAFT MOUNTING FASTENING	59
4.3.1	Torque arm: Mounting position	59
4.3.2	Torque arm: Dimensions	61
4.4	MACHINE AXIS	62

5. NMRV - PERFORMANCES

5.1	NMRV/NMRV-P WORM GEARED MOTOR (50Hz)	63
5.2	NRV/NRV-P WORM GEAR REDUCER - 2800 rpm	100
5.3	NRV/NMRV-P COMBINED WORM GEAR REDUCER - 2800 rpm	102
5.4	NRV/NRV-P WORM GEAR REDUCER - 1750 rpm	107
5.5	NRV/NMRV-P COMBINED WORM GEAR REDUCER - 1750 rpm	110
5.6	NRV/NRV-P WORM GEAR REDUCER - 1400 rpm	116
5.7	NRV/NMRV-P COMBINED WORM GEAR REDUCER - 1400 rpm	119
5.8	NRV/NRV-P WORM GEAR REDUCER - 1140 rpm	125
5.9	NRV/NMRV-P COMBINED WORM GEAR REDUCER - 1140 rpm	128
5.10	NRV/NRV-P WORM GEAR REDUCER - 900 rpm	134
5.11	NRV/NMRV-P COMBINED WORM GEAR REDUCER - 900 rpm	137
5.12	NRV/NRV-P WORM GEAR REDUCER - 500 rpm	143
5.13	NRV/NMRV-P COMBINED WORM GEAR REDUCER - 500 rpm	146
5.14	IHW/NMRV-P WORM GEAR REDUCER WITH PRESTAGE - 1750 rpm	152
5.15	IHW/NMRV-P WORM GEAR REDUCER WITH PRESTAGE - 1400 rpm	154
5.16	IHW/NMRV-P WORM GEAR REDUCER WITH PRESTAGE - 1140 rpm	156
5.17	IHW/NMRV-P WORM GEAR REDUCER WITH PRESTAGE - 900 rpm	158

6. SALES CONDITIONS

6.1	SALES CONDITIONS	160
-----	------------------------	-----

Motovario® corporate philosophy aims to promote the company's brand and products at an international level with determination and transparency, while constantly striving to offer innovative solutions for satisfying and anticipating the demand of the market. Motovario® provides technologically advanced solutions in the transmission components field for industrial and civil applications worldwide.

The company

At Formigine, the heart of Modena's industrial district, Motovario® boasts a production plant spanning 50,000 m² that employs 500 people.

1965 Foundation of Motovario

1998 Acquisition of Spaggiari Trasmissioni, an important brand in the mechanical technology sector.

2006 Motovario acquisition by a private investment fund managed by Synergo SGR, in order to guarantee its development and support its expansion throughout the world.

2014 Acquisition of Pujol.

2015 Acquisition by TECO.

At the core of Motovario® lies an evolved production process based on technological solutions that convert power into movement. Motovario® is at the heart of the production processes that drive industries worldwide. Quality and reliability are the company's fundamental assets. Motovario® is present throughout the world with branches in France, Spain, Germany, England, China, the United States and India. The sales network and customer service guarantee immediate and high-quality support to all customers. In addition, the company boasts a worldwide network of MAC (Motovario Assembly Centre). Qualified assembly centres are present, in Italy, Australia, Benelux, Bulgaria, China, Finland, France, India, Ireland, Israel, Malaysia, Poland, Portugal, South Korea, Spain, Sweden, Turkey, United Kingdom, Ukraine and USA. The company is able to offer a wide range of products: speed variators, right-angle, helical-bevel, shaft-mounted, worm gear reducers and gearmotors, electric motors, inverter and inverter drives. Maximum quality and precision are ensured by the cutting-edge technologies implemented in the production process. 170 numerical control machines, served by LGV lines for storage in automatic warehouses, ensure a high standard of efficiency for the Motovario® production department.

The highly automated assembly lines are supported by a specific computerised system. The process statistical control system manages the production process to avoid rejects, by enabling the operator to monitor all the processing phases. The annealing, tempering, hardening and carburizing treatments are carried out inside the plant. The plant operates on a 24-hour basis, including holidays. Reliability, resilience and versatility are the distinctive features of Motovario® products, the most qualified solution to any power transmission requirement.

Main fields OF APPLICATIONS

- Mechanical-electromechanical industry (car washing, pumps, barriers & automatic doors, circuit breakers)
- Ceramic industry (ovens, press feeding systems)
- Food, farming, oenology industry
- Wood, marble, glass industry
- Packaging & bottling industry
- Textile, shoes, leather industry
- Transport, logistic industry
- Construction industry
- Milling, animal husbandry, flower industry
- Machine tools & steel industry
- Mining, quarry, cement industry
- Energy industry (solar, nuclear, biomass, wind)
- Amusement industry (theatres, leisure parks, kiddy rides)
- Chemical & pharmaceuticals industry
- Paper & printing industry
- Plastic & rubber industry
- Telecommunications industry (satellite orientation systems, military radar)
- Engineering and consultant companies

Certifications

Our products can be manufactured to conform with the ATEX Directive 2014/34/UE. In addition, the safety and quality of our motors, geared motors and motovariators is guaranteed by the EAC (EurAsian Conformity) certification, an essential requirement for products exported to the Russian Federation. Our motors are UL certified, which guarantees their safety and quality requirements for the North American market.

Quality CONCEPT

Motovario® has obtained the quality certification renewal of its production system in conformity to the UNI EN ISO 9001:2008 standard. This internationally recognised certification acknowledges the company's commitment and drive geared towards constantly improving products, projects and services offered. Moreover, the company has obtained the OHSAS 18001:1999 (Occupational Health and Safety Assessment Series) certification, which defines the requirements of the workplace safety and health management system.

Research & DEVELOPMENT

Technological innovation: a crucial factor for competing in the market. In the company's 50-year history, research and change have been the pivotal factors in guaranteeing competitiveness at a global level, thanks to increasingly advanced products in terms of performance and reliability. Each year the company invests an increasing amount of its turnover in research and development, geared towards promoting the constant study and analysis of products, control processes and performance certification. In order to ensure that customers receive products that comply with the requested performance levels, the company carries out simulations on all new products, including NVH (Noise, Vibration, Harshness) tests effected in the advanced semi-anechoic chamber.

Customer CARE

Innovative instruments and software applications supporting the technical and logistic requirements of our partners worldwide guarantee a timely and customised service. The experience acquired by Motovario® has led to the creation of the new online portal MyMotovario 4.0, which allows for selecting products and exporting their 3D file. As a result, designers and engineering departments can download the three-dimensional model of the requested product and implement it directly in their own layout. In order to maximise customer service and quality, Motovario® offers all its customers the following online services: Order Tracking, which allows for monitoring the progress of an order in real time, and the Stock Availability service, through which users may check the availability (stock) of our products, both in the Italian plant and in the various branches.

Motovario chooses technological evolution.

Motovario® has chosen technological evolution and actively collaborates with the Faculty of Engineering of the University of Modena and Reggio Emilia and of the University of Bologna.

Reliability, sturdiness, versatility

These are the distinctive traits of Motovario products. A broad range of transmission products that provide a competent, innovative solution to each and every power application need. Cutting-edge tools, unrelenting research efforts and ongoing commitment to upgrading manufacturing equipment to the latest state-of-the-art enable us to offer high quality and performance standards to cater to industry requirements and the broadest variety of applications. Motovario ranks among the leading, well-reputed companies in Italy engaged in the design, manufacture and sales of transmission products for industrial and civil applications. The entire manufacturing process takes place in Formigine and Ubersetto plants, in Modena area, with an overall surface area of over 50.000 sq m. and a workforce of about 500 people. 170 numerically controlled machines and cutting-edge handling, storage and assembly automated systems ensure that all products meet high quality standards. The network includes more than 40 Motovario-certified assembly centres, with the capability to supply products in a broad range of versions, including customised versions, high service capacity and fast response. As a result, our product offering can cater to the needs of all plant engineering sectors, in all industries and for different applications, and includes: speed variators, helical, bevel-helical, parallel helical, worm gear reducers and gearmotors, electric motors and motor-inverters. All of the products we manufacture share such common features as reliability, sturdiness and versatility, topped with a high innovation content. At the heart of a company's technological innovation is the ability to develop integrated tools for computer-aided calculation simulation and management of different processes as part of product development. When simulating operating, setup and process conditions, it is also necessary to analyse and optimize the overall functional design of a product using a synergistic approach. This is achieved by implementing an exhaustive experimental plan, without using interpolation or approximation, as they frequently allow criticalities or any oversizing which is not conducive to maximising quality/cost ratio to go unnoticed.

High-efficiency method for calculation according to standards

A set of specific functions have been developed to this end. A few significant examples include functions to:

- Optimise individual reduction ratios and the combinations of the different reduction stages based on parametrisable target normal series;
- Calculate torque values and maximum permissible external forces for gear reducer units, using iterative numeric algorithms to confirm target life/safety values of components;
- Create databases for loading a FEM structural analysis model by automatically writing all reaction components of bearings under all load conditions to a specific file, with automatic selection of critical cases that need to be verified.

Another goal of the method is to create synergy between calculation according to standards and FEM structural calculation and the implementation of FEM model loading procedures, so as to simplify input data, meshing and constraint criteria

Competitiveness and operational benefits of the new method

This method offers many practical advantages over traditional calculation procedures within the company, namely:

- Iterative optimisation of project since setup stage;
- Accurate assessment of the various service factors and reliability levels for the entire gear reducer unit and for all operating conditions as per catalogue rating or customer specific requirements;
- Faster support to customers in analysing tailored product configurations;
- Integrated corporate databases that can be updated in real-time.

Range extension and ongoing evolution

The steady, significant growth of Motovario Group is achieved thanks to an ongoing search for new calculation and design tools, as well as to customer service. The new tools identified have led to innovation, improved product reliability as well as positive developments in market management. The following software products are used for design, calculation and management:

- Solidworks;
- Kisoft;
- Kissys;
- Ansys;
- FEM modelling analysis software;
- Circuit design and simulation software;
- Specific spreadsheets;
- SAP.

In MyMotovario 4.0 portal, PRODUCT SELECTION includes a section named APPLICATIONS where customers can enter application data and find out which gear reducer suits them best in a matter of minutes.

MOTOVARIO Products

<p>HELICAL GEAR REDUCERS</p> <p>Cast iron or aluminum casing Output shaft up to 90 mm Mn₂ up to 8.600 Nm Reduction stages 1, 2, 3 Ratios up to 354 Atex units</p>	
<p>HELICAL BEVEL GEAR REDUCERS</p> <p>Cast iron or aluminum casing Output shaft up to 110 mm Mn₂ up to 14.000 Nm Reduction stages 2, 3 Ratios up to 443 Atex units</p>	
<p>SHAFT MOUNTED GEAR REDUCERS</p> <p>Cast iron Output shaft up to 90 mm Mn₂ up to 10.250 Nm Reduction stages 2, 3 Ratios up to 395 Atex units</p>	
<p>WORM GEAR REDUCERS</p> <p>Cast iron or aluminum casing Output shaft up to 50 mm Mn₂ up to 2.700 Nm Ratios up to 1083 Atex units</p>	

PARALLEL HELICAL AND BEVEL HELICAL GEAR REDUCERS FOR MIDDLE HEAVY INDUSTRY

Cast iron casing
 Output shaft up to 180 mm
 Mn₂ up to 110.000 Nm
 Reduction stages 1, 2, 3, 4
 Ratios up to 636
 Atex units



MOTOVARIATORS AND MOTOVARIATOR-GEAR REDUCERS

Cast iron or aluminum casing
 Ratios infinite
 Mn₂ up to 5.000 Nm
 Atex units



ELECTRIC MOTORS

Power ratings up to 90 kW
 Poles 2, 4, 6
 Three-phase and single-phase, built-in brake, dual polarity
 Protection class up to IP66



DRIVES

DRIVON - motoinverter

Three phase and single phase power supply
 High dynamics sensorless vectorial control
 Power ratings up to 5,5 kW
 Standard integrated STO
 Integrated field bus
 Optional field bus





ATEX Certification

The gear reducers described in this catalogue, defined as “ATEX”, were designed and manufactured in compliance with: Directive **ATEX 2014/34/UE**.

If used by following the instructions set forth in the INSTALLATION AND USE INSTRUCTIONS Atex Manual (provided as an attachment to the supplied products), ATEX MOTOVARIO gear reducers can be used in one of the following environments:

Group II

Category 2G and 2D

Zone 1/21 for gases and dusts (gas group IIB) with the following protection methods:

Protection against ignition:

EN13463-5 (c) constructional safety

EN13463-8 (k) liquid immersion

Group II

Category 3G and 3D

Zone 2/22 for gases and dusts

Protection against ignition:

EN13463-5 (c) constructional safety

The room temperature envisaged for the application must range between -20 and + 40 °C (*).

The products certified for use in Zone 1/21 can be used also in Zone 2/22. To identify the environment inside which the Atex certification of the special gear reducer is limited, refer to Atex Performance Tables.

The classified units are manufactured and marked to comply with the provisions of Directive **ATEX 2014/34/UE**.

UNINTENDED USE

It is strictly forbidden to use the gear reducer:

- inside an area with equipment category I (mines likely to become endangered by firedamp);
- inside an Area classified as more severe than specified on product label;
- at a room temperature not falling within the specified limits (*);
- under conditions (P1, n1, M2) that, even individually, exceed the values specified inside Atex Performance Tables.

1.4.1 Symbols

Physical dimension	Symbol	Symbol units of measure	Input	Output
Power	P	[kW]	P ₁	P ₂
Requested power	Pr	[kW]	Pr ₁	Pr ₂
Nominal power	Pn	[kW]	Pn ₁	Pn ₂
Torque	M	[Nm]	M ₁	M ₂
Nominal torque	Mn	[Nm]		Mn ₂
Requested torque	Mr	[Nm]	Mr ₁	Mr ₂
Speed	n	[rpm]	n ₁	n ₂
Load	F	[N]		
Radial load	Fr	[N]	Fr ₁	Fr ₂
Radial axial	Fa	[N]	Fa ₁	Fa ₂
Reduction ratio	i			
Dynamic efficiency	η _d			
Service factor	f.s.			
Static	s			
Dynamic	d			
Calculated	c			
Maximum	max			
Minimum	min			
Moment of inertia	J	[kgm ²]	J ₁	
Ambient temperature	T _{amb}	[°C]		
Dimension		[mm]		
Number of screw threads	Zl			
Lead angle	Υ	[° ' "]		
Axial module	Mx			
Dynamic efficiency of n1= 1400 rpm	η _δ (1400)			
Static efficiency	η _s			

1.4.2 Formulas

REDUCER		
Starting or stopping time	$t = v / a$	[s]
Velocity in rotary motion	$v = \pi * d * n / 60$ $v = \omega * r$	[m/s]
Speed velocity Angular velocity	$n = 60 * v / (\pi * d)$ $\omega = v / r$	[rpm] [rad/s]
Acceleration or deceleration according to a starting / stopping time	$a = v / t$	[m/s ²]
Angular acceleration	$\alpha = n / (9,55 * t)$ $\alpha = \omega / t$	[rad/s ²]
Starting or stopping distance (according to acceleration / deceleration or angular velocity)	$s = a * t^2 / 2$ $s = v * t / 2$	[m]
Horizontal translation force	$F = \mu * m * g$	[N]
Vertical translation force (lifting)	$F = m * g$	
Inclined plane translation force	$F = m * g (\mu * \cos\beta + \sin\beta)$	
m= mass [kg]; g= gravity acceleration [m/s ²]; μ = friction coefficient; β = angle of inclination		
Moment of inertia	$J = m * v^2 / \omega^2$	[kgm ²]
Torque	$M = F * d / 2$ $M = J * \omega / t$	[Nm]

MOTOR and GEARMOTOR		
Starting time	$t_a = (J_{ext} + J_m) * n_n / 9,55 + (M_{peak} - M_r)$	[s]
Braking time	$t_s = (J_{ext} + J_m) * n_n / 9,55 + (M_{peak} + M_r)$	[s]
Motor rotation angle during starting	$\varphi = n_n * t_a / 19,1$	[rad]
Motor rotation angle during braking	$\varphi = n_n * t_s / 19,1$	[rad]
Power available at the shaft of single phase motor	$P = V * I * \eta * \cos\omega$	[W]
Power available at the shaft of three phase motor	$P = 1,73 * V * I * \eta * \cos\omega$	[W]

RUNNING at 60Hz		
Speed velocity at 60Hz	$n_{60Hz} = 1,2 * n_{50Hz}$	[rpm]
Power at 60Hz	$P_{60Hz} = P_{50Hz} * V_{60Hz} / V_{50Hz}$	[kW]
If input voltage at 60 Hz (V_{60Hz}) corresponds to winding voltage at 50 Hz (V_{50Hz}), power doesn't change $P_{60Hz} = P_{50Hz}$		
If input voltage at 60 Hz (V_{60Hz}) is 20% higher than winding voltage at 50 Hz (V_{50Hz}), power increases by 20% $P_{60Hz} = 1,2 P_{50Hz}$		
Torque at 60Hz	$M_{60Hz} = M_{50Hz} * P_{60Hz} / (1,2 * P_{50Hz})$	[Nm]
Service factor at 60Hz	$f.s_{60Hz} = f.s_{50Hz} * 1,175 * P_{50Hz} / P_{60Hz}$	-

1.5.1 Product selection

For correctly selecting a gear reducer or geared motor, several essential pieces of data are required:

1. The rotational input speed to the gear reducer (n_1) and the rotational output speed (n_2). Through these two values it is possible to calculate the reduction ratio (i) of the gear reducer using the following formula: $i = n_1/n_2$
2. The torque required by the application (Mr_2).

The geared motor or gear reducer can be selected once this data is known.

This guide helps you to select the right product in just a few steps:

Geared motor selection

1. Determine the application's actual service factor (**s.f.**). This parameter depends on the type of load of the powered machine, the number of starts per hour and the hours of operation (refer to the "Service factor" paragraph).
2. Calculate the input power Pr_1 using the required torque value Mr_2 , the speed n_2 and dynamic efficiency value. $Pr_1 = (Mr_2 * n_2) / (9550 * \eta_d)$. The dynamic efficiency value depends on the type of gear reducer and on the number of gear reduction stages. (To calculate the efficiency value see its page).
3. Consult the geared motor performance tables and identify a normalised power value Pn_1 exceeding the required power Pr_1 , such that: $Pn_1 \geq Pr_1$
4. Once the suitable nominal power has been identified, select the geared motor capable of generating the rotational speed closest to the desired n_2 value and with service factor s.f. greater or equal to that required by the application.

In the geared motor selection tables the combinations include 2-pole, 4-pole and 6-pole motors powered at 50Hz.

Gear reducer selection

1. Determine the application's service factor (**s.f.**) (consult to the "Service factor" paragraph on its page).
2. Calculate the reduction ratio i from the requested output speed n_2 and from the input speed n_1 . $i = n_1/n_2$
3. Calculate the torque Mc_2 for selecting the gear reducer through the torque required by the application Mr_2 and the service factor s.f.: $Mc_2 = Mr_2 * (f.s.)$
4. Consult the Gear Reducer Performance tables looking for the reducer that, with the reduction ratio closer to the calculated one, has a nominal torque Mn_2 so that: $Mn_2 \geq Mc_2$

Checks

Once the gear reducer or geared motor has been selected, the following checks should be performed:

A. Maximum torque

Generally, the maximum torque (peak instantaneous load) that can be applied to the gear reducer must not exceed 200% of the nominal torque Mn_2 (ATEX - M_{2max}).

B. Radial loads

1. Verify that the radial loads acting on the input and/or output shafts are within with the values indicated in the catalogue. If they exceed these values, increase the size of the gear reducer or modify the external load capacity. During the checking phase, it is important to remember that the values indicated in the catalogue refer to loads acting on the mid-point of the shaft protrusion, therefore, if the load is applied to a different position, appropriate formulas must be used to calculate the admissible load in the desired position (refer to the "Radial loads" paragraph).

2. If accessory output shafts are present, make sure that the applied load is compatible with shaft size. If help is needed: contact MOTOVARIO TECHNICAL SERVICE.

C. If an electric motor is going to be fitted to the selected gear reducer, check for its applicability by referring to the configuration table (see paragraph "Motor flange availability"). From IEC 180 motors, verify if necessary to support the motor with feet. In case of need please contact MOTOVARIO TECHNICAL SERVICE.



**For Atex product selection, use the service factor "f.s. Atex".
For Atex product Selection, refer to Atex Gear Reducer Performance tables.**

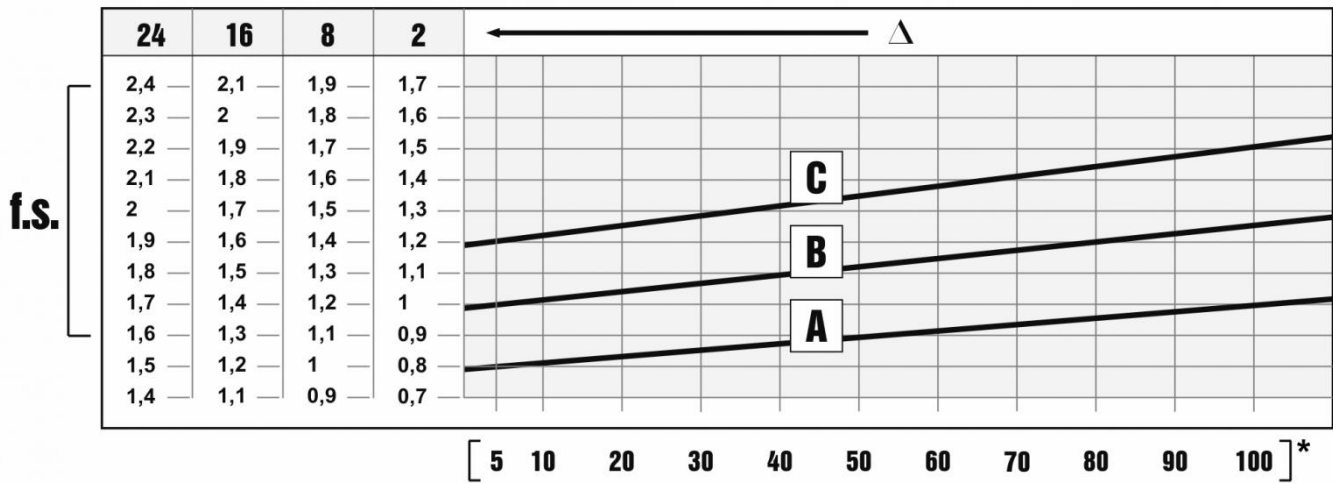

The service factor (f.s.) depends on the operating conditions the gear reducer is subjected to. The parameters that need to be taken into consideration to select the most adequate service factor correctly comprise:

- type of load of the operated machine : A - B - C
- length of daily operating time: hours/day (Δ)
- start-up frequency: starts/hour (*)

LOAD:

- **A** - uniform = $f_a \leq 0,3$
- **B** - moderate shocks = $f_a \leq 3$
- **C** - heavy shocks = $f_a \leq 10$

$f_a = J_e/J_m$

- J_e [kgm^2] moment of reduced external inertia at the drive-shaft
- J_m [kgm^2] moment of inertia of motor

If $f_a > 10$ call MOTOVARIO TECHNICAL SERVICE.

In the case of a variable speed reducer, once determined the service factor of the application it is necessary to compare this value with the safety factor of the S reducer reported in the selection tables, verifying $S \geq f.s.$ condition. The maximum number of admissible starts depends on the type of application. Approximately, the figure must not exceed 5-10 for minute. Contact MOTOVARIO TECHNICAL SERVICE if you have any special requirements.

- A. Screw feeders for light materials, fans, assembly lines, conveyor belts for light materials, small mixers, lifts, cleaning machines, fillers, control machines.
- B. Winding devices, woodworking machine feeders, goods lifts, balancers, threading machines, medium mixers, conveyor belts for heavy materials, winches, sliding doors, fertilizer scrapers, packing machines, concrete mixers, crane mechanisms, milling cutters, folding machines, gear pumps.
- C. Mixers for heavy materials, shears, presses, centrifuges, rotating supports, winches and lifts for heavy materials, grinding lathes, stone mills, bucket elevators, drilling machines, hammer mills, cam presses, folding machines, turntables, tumbling barrels, vibrators, shredders.

To install the gear reducer it is necessary to note the following recommendations:

- Check the correct direction of rotation of the gear reducer output shaft before fitting the unit to the machine.
- In the case of particularly lengthy periods of storage (4/6 months), if the oil seal is not immersed in the lubricant inside the unit, it is recommended to change it since the rubber could stick to the shaft or may even have lost the elasticity it needs to function properly.
- Whenever possible, protect the gear reducer against solar radiation and bad weather.
- Ensure the motor cools correctly by ensuring good passage of air from the fan side.
- In the case of ambient temperatures $< -5^{\circ}\text{C}$ or $> +40^{\circ}\text{C}$ call MOTOVARIO TECHNICAL SERVICE.
- The various parts (pulleys, gear wheels, couplings, shafts, etc.) must be mounted on the solid or hollow shafts using special threaded holes or other systems that anyhow ensure correct operation without risking damage to the bearings or external parts of the units. Lubricate the surfaces in contact to avoid seizure or oxidation.
- Painting must definitely not go over rubber parts and the holes on the breather plugs, if any.
- For units equipped with oil plugs, replace the closed plug used for shipping with the special breather plug.
- Check the correct level of the lubricant through the indicator, if there is one.
- Starting must take place gradually, without immediately applying the maximum load.
- When there are parts, objects or materials under the motor drive that can be damaged by even limited spillage of oil, special protection should be fitted.

Please note: in the event of a cover with adhesive label having to be replaced, you will have to stick a new label onto the new cover. Please contact Motovario and we can supply you with one.

Motovario products are supplied with the following surface treatment features:

Die-cast aluminium alloy cases for gears (sizes 025-110)

Die-cast materials undergo the following surface cleaning operations:

- De-burring by means of a mechanically operated shearing system.
- Accurate shot-peening.
- Painting.
- Washing and passivation.

Grey-coloured cast-iron cases for gears (sizes 130-150)

- Die-cast materials are always painted.

Painting specifications:

- Orange-peel blue epoxy-polyester RAL 5010. Polyester resin based heat-hardening powders, altered with epoxy resins.

Mechanical properties: Tests carried out onto degreased Unichim white lattens (film thickness: 60 microns) comply with the following specifications: adherence (ISO2409).

Heat resistance: 24 HOURS AT 150°C.

Corrosion strength: ASTM B 117/97 salt fog from 100 to 500 hours depending on the support's preliminary treatment.

Performance:

- Loading capacity in accordance with: ISO 14521, DIN 3996, BS 721, AGMA 6034, ISO 6336, DIN 3990, DIN 743, ISO 281.

2.2.1 Designation

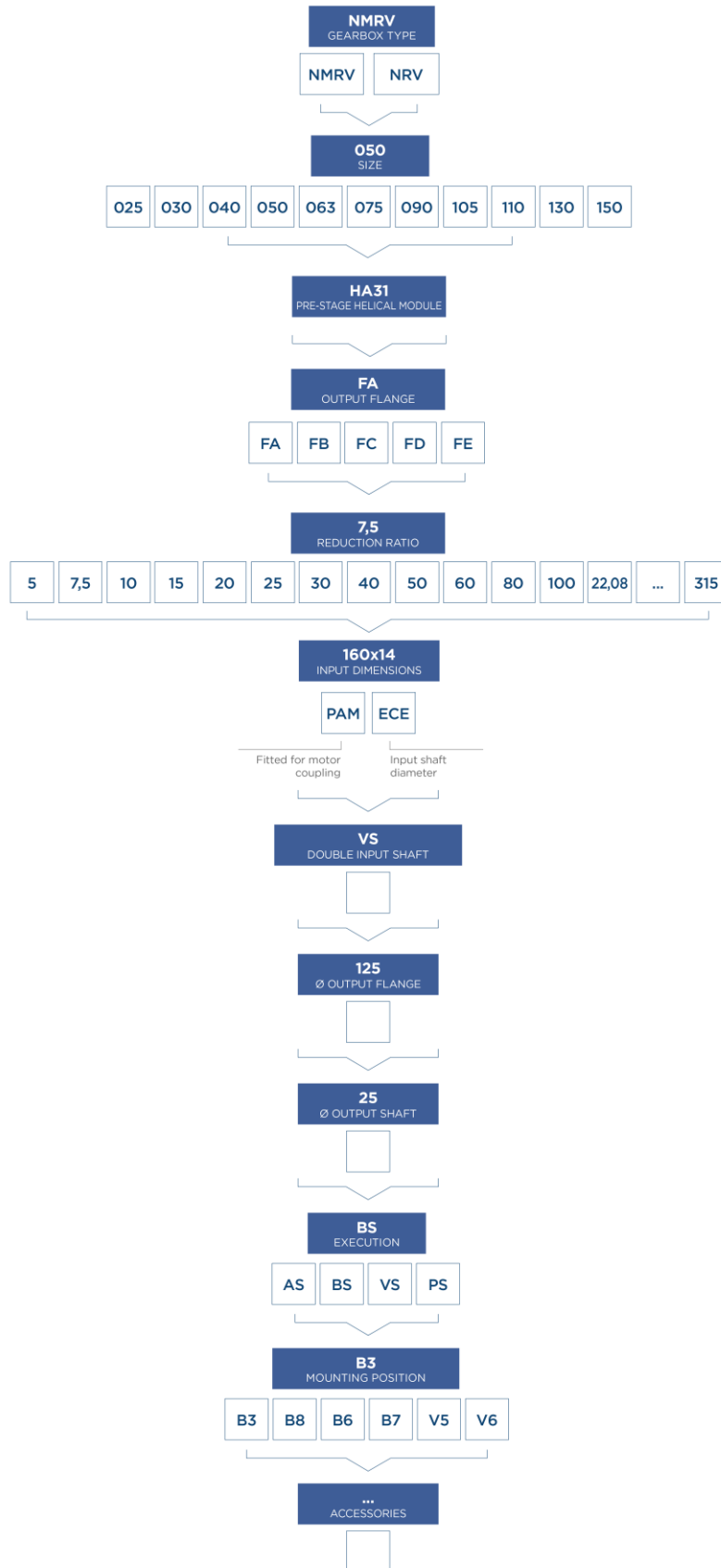

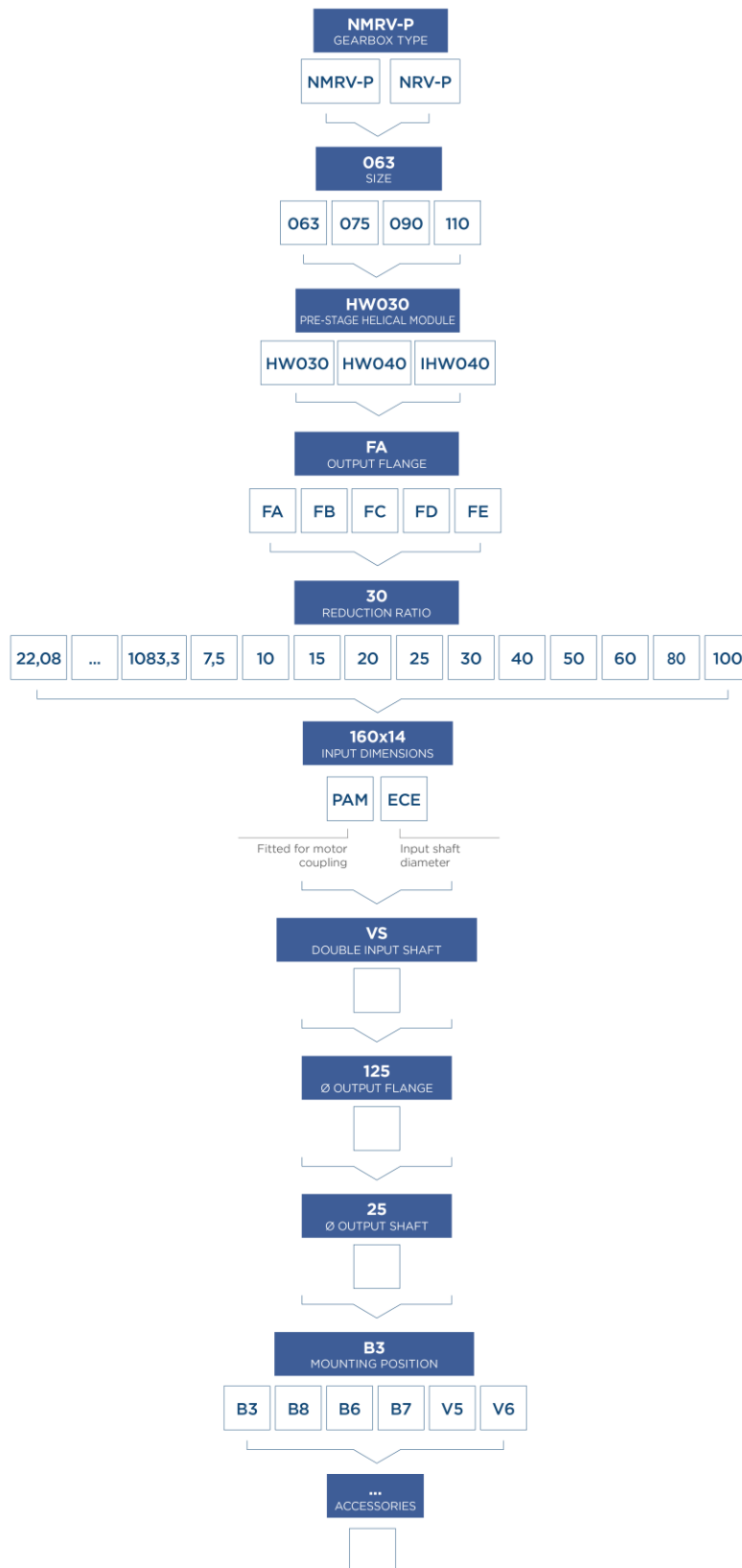

2.2.2 Versions

NMRV

NMRV 025-050 / NMRV 130-150

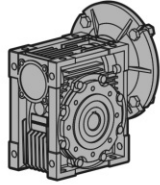

NMRV 025-050 F / NMRV 130-150 F

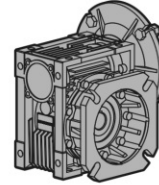

NRV 030-050 / NRV 130-150

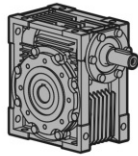

NRV 030-050 F / NRV 130-150 F

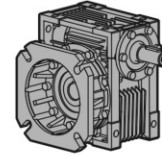

NMRV-NMRV...

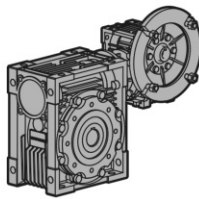

NRV-NMRV... F

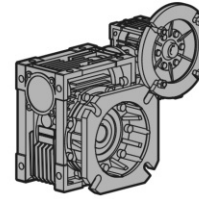

NRV-NMRV...

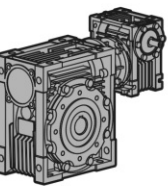

NRV-NMRV... F

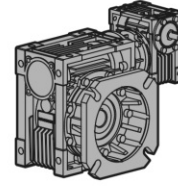

HA31+NMRV...

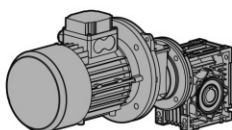

HA31+NMRV... F

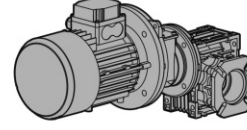

NMRVpower

NMRVpower 063-110

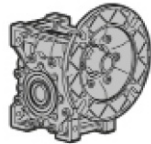

NMRVpower 063-110 F

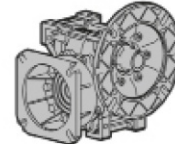

NRVpower 063-110



NRVpower 063-110 F

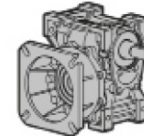

**NMRV-NMRVpower...
NMRVpower-NMRV...
NMRVpower-NMRVpower...**

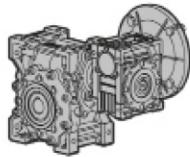

**NMRV-NMRVpower... F
NMRVpower-NMRV... F
NMRVpower-NMRVpower... F**

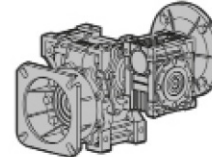

**NRV-NMRVpower...
NRVpower-NMRV...
NRVpower-NRVpower...**

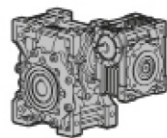

**NRV-NMRVpower... F
NRVpower-NRV... F
NRVpower-NRVpower...F**

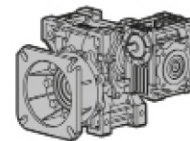

NMRVpower/HW...

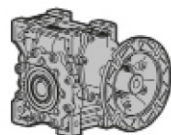

NMRVpower/HW... F

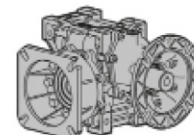

2.2.3 Modularity

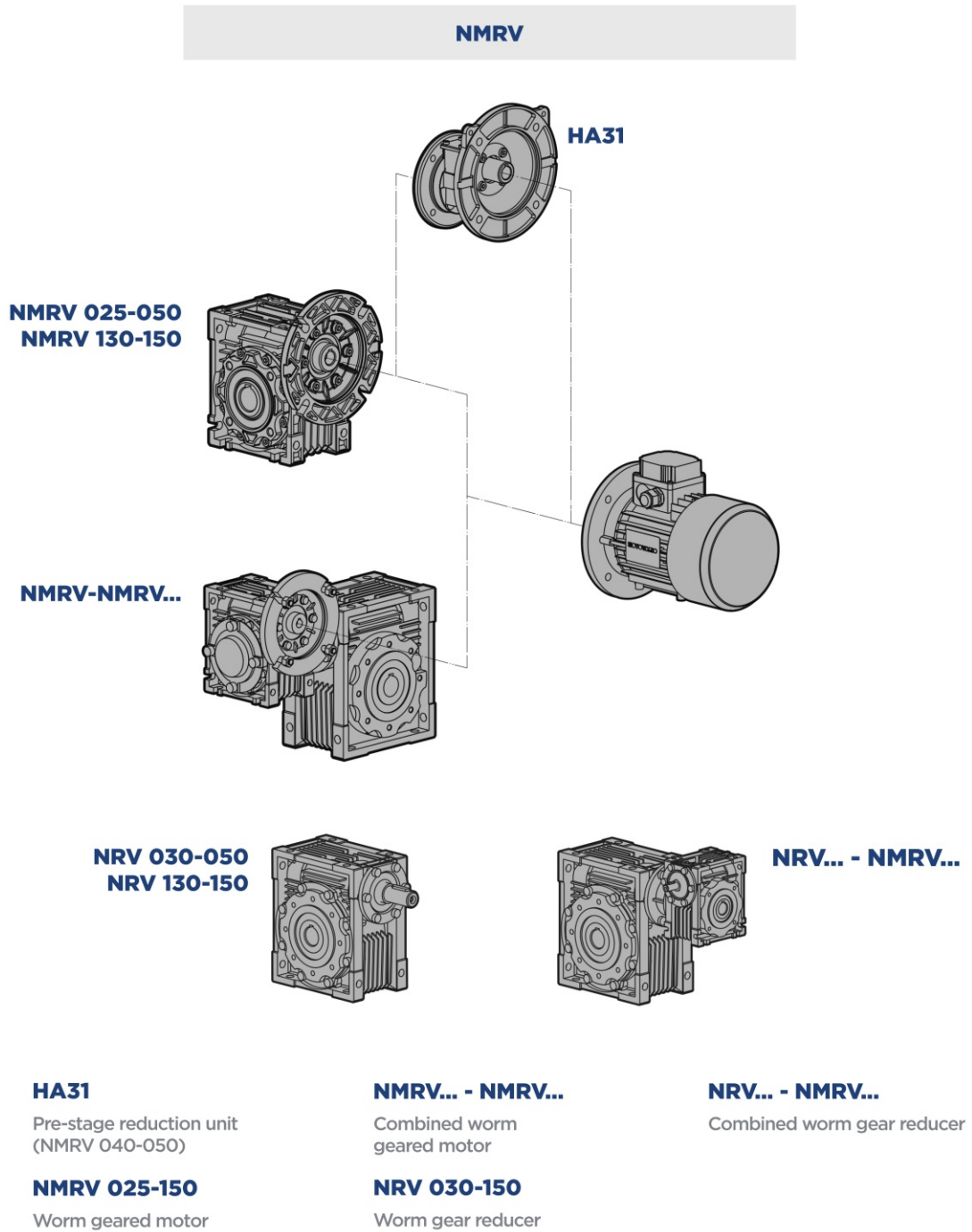

NMRVpower

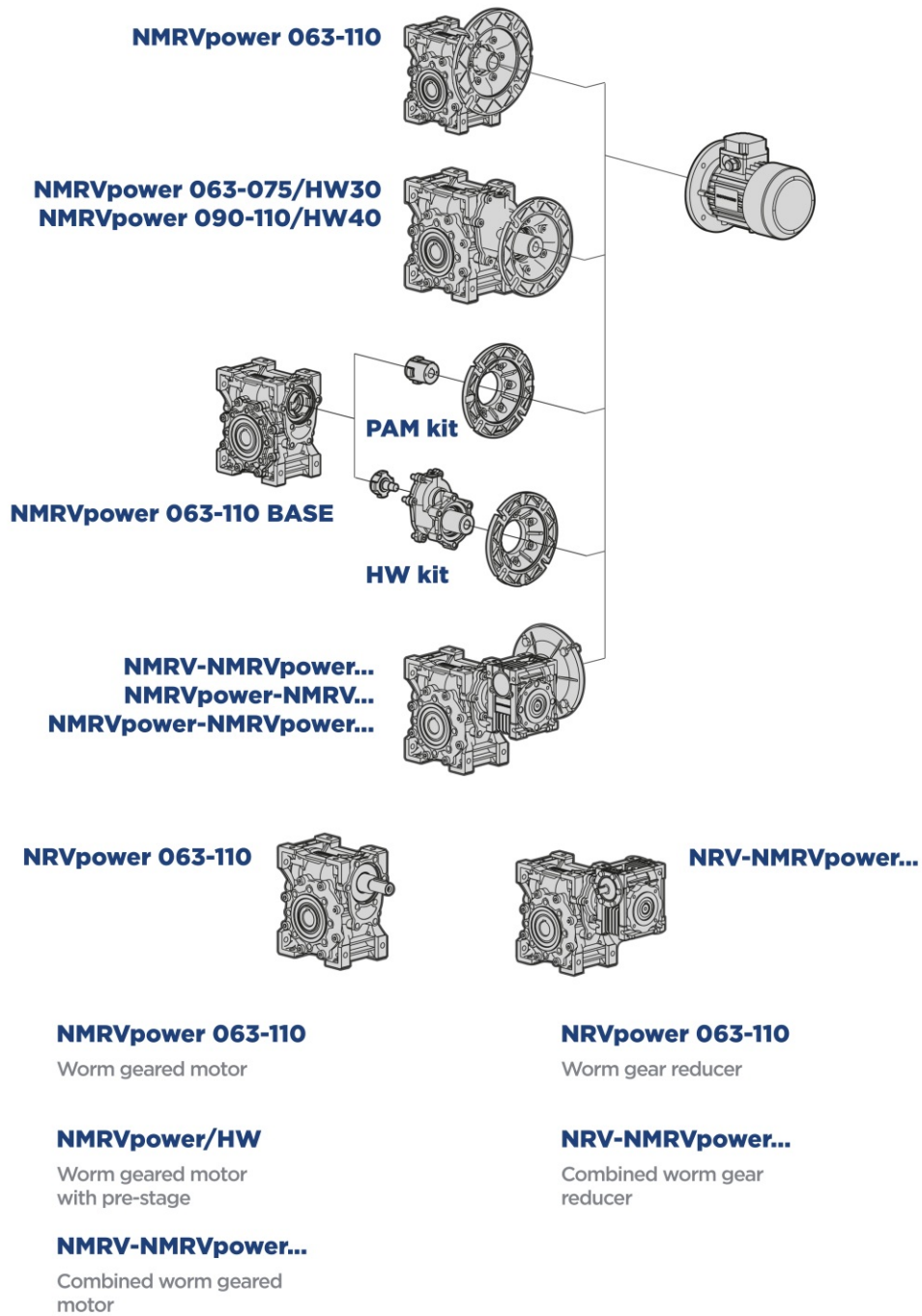

2.3.1 Mounting positions

The mounting position of the gear unit identifies its space orientation. Unless specified otherwise, the standard positions are B3/BS. B3 mounting position, as from a technical point of view, ensures lower oil splash, better lubrication and less heating. For positions not envisaged, it is necessary to call our Technical Service. "U" version is related to sizes from NMRV/NMRV-P 025-075 and NRV/NRV-P 030-063. For these sizes it is not necessary to specify mounting position. For NMRV 090-110 mounting position B3 is valid also for B6-B7-B8. Mounting positions V5 and V6 must be specified. For NMRV 130-150 mounting positions B3-B6-B7-B8-V5-V6 must be specified.

(*NMRV-P - HW) Execution only in BS. For NMRV-P/HW 063-075 mounting position B3 is valid also for B6-B7-B8-V6. Mounting position V5 must be specified.

(**HA31+NMRV) The mounting position is U and it is valid for all mounting positions.

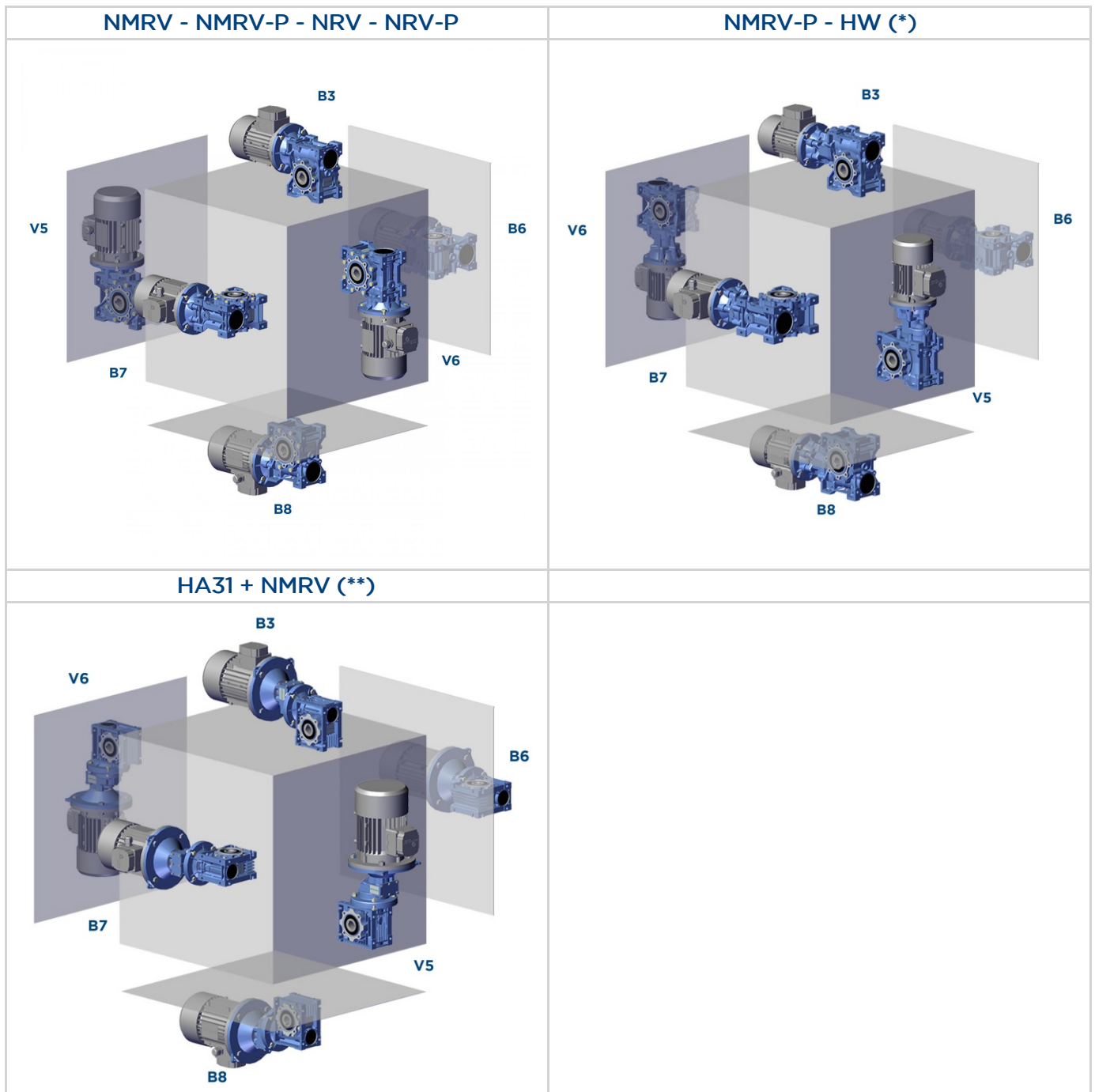

Execution

NMRV/NMRV-P+NMRV/NMRV-P - NRV/NRV-P+NMRV/NMRV-P

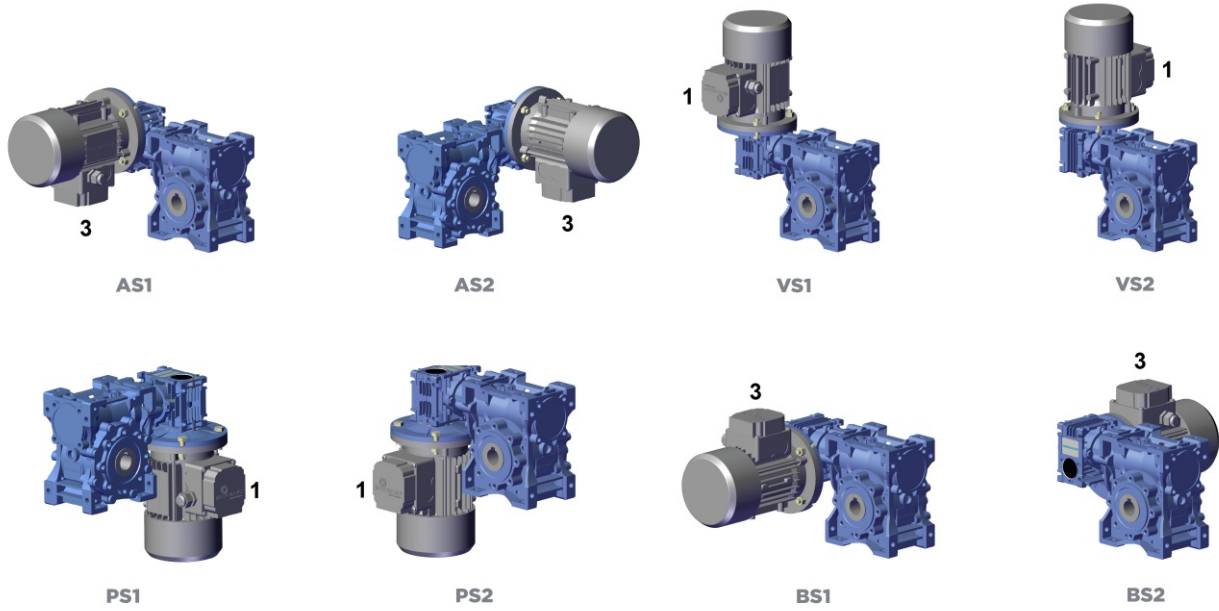

HA31+NMRV

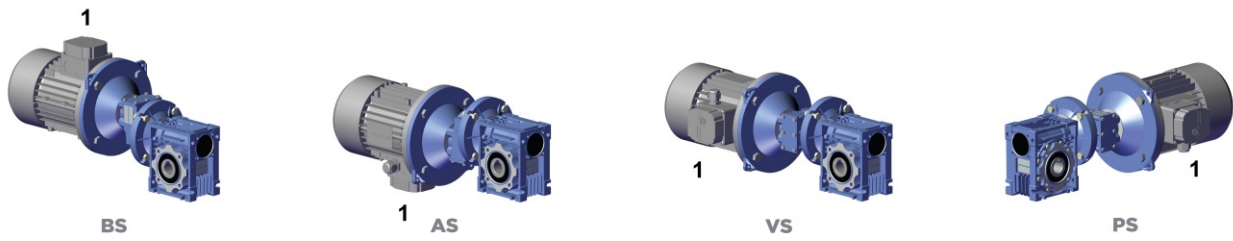

2.3.2 Position of terminal box

In the case of specific requirements, when ordering, specify the position of the terminal box as shown in the diagram. Unless otherwise specified, the gear reducer is supplied with terminal box in position 1. Terminal box position always refers to HA31 position.

NMRV - NMRV-P

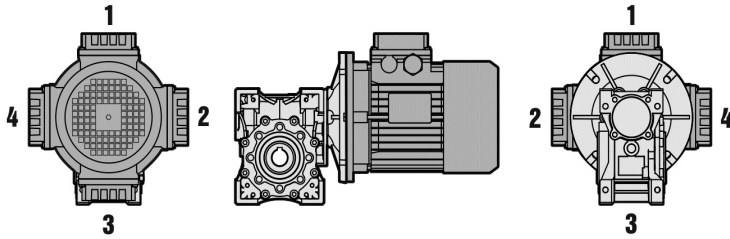

HA31+NMRV

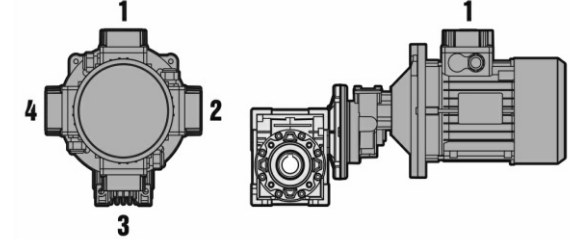

2.4.1 Efficiency

Efficiency is a parameter which has a major influence on the sizing of certain applications, and basically depends on gear pair design elements. The mesh data table shows dynamic efficiency ($n_1=1400$) and static efficiency values. These values are only valid after the unit has been run in, is being used at ambient temperatures of 25°C, where service factor is 1 and with standard lubricant.

Dynamic irreversibility

Dynamic irreversibility is achieved when the output shaft stops instantly when drive is no longer transmitted through the worm shaft. This condition requires a dynamic efficiency of $\eta_d < 0.5$.

Static irreversibility

Static irreversibility is achieved when, with the gear reducer at a standstill, the application of a load to the output shaft does not set in motion the worm shaft. This condition requires a static efficiency of $\eta_s < 0.5$.

N.B.: Vibrations and shocks can affect a gear reducer's irreversibility.

2.4.2 Irreversibility

η_d	DYNAMIC IRREVERSIBILITY
>0.6	dynamic reversibility
0.5÷0.6	low dynamic reversibility
0.4÷0.5	good dynamic irreversibility
<0.4	dynamic irreversibility

η_s	STATIC IRREVERSIBILITY
>0.55	static reversibility
0.5÷0.55	low static reversibility
<0.5	static irreversibility

The table shows approximate irreversibility classes.

The irreversibility condition of combined gear reducers is given by the units with the lowest efficiency.

	i	5	7,5	10	15	20	25	30	40	50	60	80	100
025	Z1	6	4	3	2	2	-	1	1	1	1	-	-
	Υ	35°02'	25°03'	19°19'	13°09'	10°41'		6°40'	5°23'	4°31'	3°53'		
	Mx	1,3	1,3	1,3	1,3	0,995		1,3	0,995	0,8	0,67		
	ηδ(1400)	0,87	0,85	0,83	0,79	0,75		0,67	0,62	0,58	0,55		
	ηs	0,72	0,71	0,68	0,61	0,56		0,46	0,41	0,36	0,34		
030	Z1	6	4	3	2	2	1	1	1	1	1	1	-
	Υ	27°04'	18°49'	14°20'	9°40'	7°42'	5°35'	4°52'	3°52'	3°12'	2°45'	2°07'	
	Mx	1,44	1,44	1,44	1,44	1,09	1,7	1,44	1,09	0,89	0,74	0,56	
	ηδ(1400)	0,87	0,85	0,83	0,78	0,74	0,69	0,66	0,6	0,56	0,52	0,45	
	ηs	0,72	0,67	0,63	0,55	0,5	0,43	0,39	0,35	0,31	0,27	0,23	
040	Z1	6	4	3	2	2	2	1	1	1	1	1	1
	Υ	34°19'	24°28'	18°51'	12°49'	10°23'	8°43'	6°29'	5°14'	4°23'	3°47'	2°57'	2°25'
	Mx	2,06	2,06	2,06	2,06	1,57	1,27	2,06	1,57	1,27	1,06	0,81	0,65
	ηδ(1400)	0,89	0,87	0,85	0,83	0,79	0,76	0,71	0,66	0,63	0,59	0,53	0,48
	ηs	0,74	0,71	0,67	0,6	0,55	0,51	0,45	0,4	0,36	0,32	0,28	0,24
050	Z1	6	4	3	2	2	2	1	1	1	1	1	1
	Υ	33°37'	23°54'	18°23'	12°30'	10°06'	8°29'	6°19'	5°06'	4°16'	3°40'	2°52'	2°21'
	Mx	2,56	2,56	2,56	2,56	1,95	1,58	2,56	1,95	1,58	1,32	1	0,8
	ηδ(1400)	0,89	0,88	0,87	0,83	0,8	0,77	0,73	0,68	0,64	0,6	0,54	0,5
	ηs	0,74	0,7	0,66	0,59	0,55	0,51	0,44	0,39	0,35	0,32	0,27	0,23
063	Z1	-	4	3	2	2	2	1	1	1	1	1	1
	Υ		24°31'	18°53'	12°51'	10°25'	8°45'	6°30'	5°15'	4°24'	3°47'	2°58'	2°26'
	Mx		3,25	3,25	3,25	2,48	2	3,25	2,48	2	1,68	1,27	1,02
	ηδ(1400)		0,89	0,87	0,84	0,82	0,79	0,75	0,71	0,67	0,63	0,58	0,52
	ηs		0,71	0,67	0,6	0,55	0,51	0,45	0,4	0,36	0,33	0,28	0,24
075	Z1	-	4	3	2	2	2	1	1	1	1	1	1
	Υ		26°17'	20°20'	13°52'	11°18'	9°32'	7°02'	5°42'	4°48'	4°08'	3°14'	2°40'
	Mx		3,94	3,94	3,94	3	2,42	3,94	3	2,42	2,03	1,54	1,24
	ηδ(1400)		0,89	0,88	0,86	0,83	0,81	0,77	0,73	0,7	0,66	0,61	0,56
	ηs		0,71	0,68	0,61	0,57	0,53	0,46	0,42	0,38	0,35	0,29	0,26
090	Z1	-	4	3	2	2	2	1	1	1	1	1	1
	Υ		29°11'	22°44'	15°36'	12°50'	10°54'	7°57'	6°30'	5°30'	4°46'	3°45'	3°06'
	Mx		4,84	4,84	4,84	3,69	2,98	4,84	3,69	2,98	2,5	1,89	1,52
	ηδ(1400)		0,9	0,89	0,87	0,85	0,83	0,79	0,76	0,73	0,7	0,64	0,6
	ηs		0,73	0,7	0,64	0,6	0,56	0,49	0,45	0,41	0,38	0,32	0,28
110	Z1	-	4	3	2	2	2	1	1	1	1	1	1
	Υ		28°15'	21°57'	15°02'	14°41'	12°34'	7°39'	7°28'	6°22'	5°32'	4°24'	3°39'
	Mx		5,875	5,875	5,875	4,62	3,73	5,875	4,62	3,73	3,13	2,37	1,91
	ηδ(1400)		0,9	0,89	0,87	0,86	0,85	0,8	0,79	0,76	0,73	0,68	0,64
	ηs		0,72	0,69	0,63	0,62	0,59	0,48	0,48	0,44	0,41	0,36	0,32
130	Z1	-	4	3	2	2	2	1	1	1	1	1	1
	Υ		28°41'	22°19'	15°18'	13°52'	11°49'	7°47'	7°02'	5°58'	5°11'	4°07'	3°24'
	Mx		6,97	6,97	6,97	5,4	4,37	6,97	5,4	4,37	3,67	2,77	2,23
	ηδ(1400)		0,91	0,89	0,87	0,87	0,85	0,81	0,79	0,76	0,73	0,69	0,65
	ηs		0,72	0,69	0,63	0,61	0,58	0,49	0,46	0,43	0,39	0,34	0,3
150	Z1	-	6	4	3	2	2	2	1	1	1	1	1
	Υ		32°09'	24°35'	17°27'	12°53'	11°19'	9°50'	6°32'	5°43'	4°57'	3°55'	3°14'
	Mx		5,5	6,155	5,5	6,155	5	4,193	6,155	5	4,193	3,17	2,55
	ηδ(1400)		0,91	0,9	0,88	0,87	0,85	0,84	0,79	0,77	0,74	0,69	0,65
	ηs		0,73	0,71	0,66	0,6	0,57	0,54	0,45	0,42	0,39	0,33	0,29

These values can be detected on the output shaft, with the input shaft locked. For applications requiring controlled or reduced backlash, please contact our technical department.

NMRV 030	NMRV 040	NMRV 050	NMRV-P 063	NMRV-P 075	NMRV-P 90	NMRV-P 110	NMRV 130	NMRV 150
20' - 44'	18' - 34'	18' - 32'	18' - 28'	16' - 24'	6' - 18'	6' - 14'	6' - 12'	6' - 12'

The worm screw rotation is right-handed.

DIRECTION OF ROTATION - HIGH SPEED SHAFT

NMRV - NRV - SW - ISW



MOUNTING POSITION **B3**

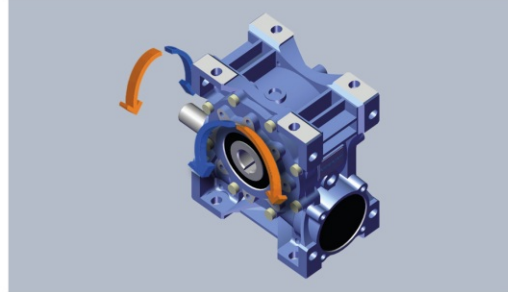

MOUNTING POSITION **B8**

NMRV + NMRV - SW + SW - NRV + NMRV - ISW + SW

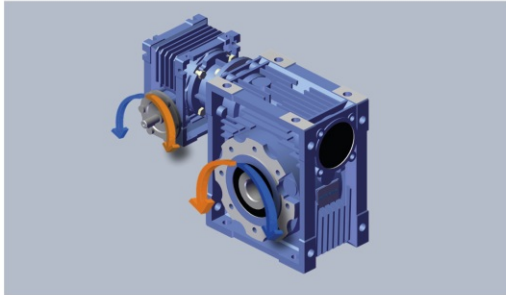

MOUNTING POSITION **AS1**

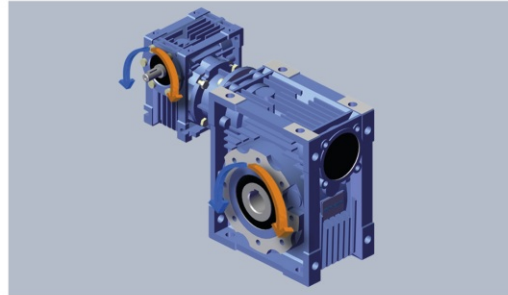

MOUNTING POSITION **BS1**

2.8.1 Critical applications

NMRV - NMRV-P	NMRV				NMRV-P				NMRV	
	025	030	040	050	063	075	090	110	130	150
V5: 1500 < n1 < 3000	✓	✓	✓	✓	B	B	B	B	B	B
n1 > 3000	B	B	B	B	B	B	A	A	A	A
V6	B	B	B	B	B	B	B	B	B	B

H	A31	HW+NMRV-P	030+063	030+075	040+090	040+110
V5 - V1: 1500 < n1 < 3000	✓	1500<n1<3000	B	B	B	B
n1 > 3000	B	n1>3000	A	A	A	A
V3 - V6	B	V5 - V6	B	B	B	B

✓ Verified application

A Application not recommended

B Check the application and/or call MOTOVARIO TECHNICAL SERVICE.

2.8.2 Information

The performance given in the catalogue correspond to mounting position B3 or similar, when the first stage is not entirely immersed in oil. For other mounting positions and/or particular input speeds, refer to the tables that highlight different critical situations for each size of gear reducer. It is also necessary to take due consideration of and carefully assess the following applications by calling MOTOVARIO TECHNICAL SERVICE:

- To avoid the use as multiplier.
- Use in services that could be hazardous for people if the gear reducer fails.
- Applications with especially high inertia.
- Use as a lifting winch.
- Applications with high dynamic strain on the case of the gear reducer.
- In places with T_{amb} under -5°C or over 40°C .
- Use in chemically aggressive environments.
- Use in a salty environment.
- Mounting positions not envisaged in the catalogue.
- Use in radioactive environments.
- Use in environments pressures other than atmospheric pressure.

Avoid applications where even partial immersion of the reducer is required.

In the presence of overloading due to full load, braking, shocks or other static and dynamic causes, please verify that the peak torque is less than $2 \cdot M_{n2}$.

2.9.1 NMRV - NMRV-P Motor flange availability

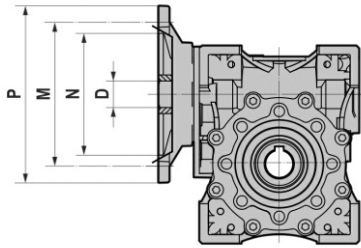

- (*) Low profile key supplied by Motovario.
- (•) Motor-ratio combination feasible.
- (**) Motor-ratio combination not feasible.
- (+) Motor-ratio combination not to be used, out of warranty terms.

The table report possible configurations strictly based on geometric criteria. To determine the compatibility of a motor-gear unit assembly in terms of mechanical factors, double check the selected configuration against the rating charts for NRV/NRV-P performances.

NMRV NMRV-P	PAM IEC	N	M	P	D	i											
						5	7,5	10	15	20	25	30	40	50	60	80	100
025	56B14	50	65	80	9	•	•	•	•	•	**	•	•	•	•	**	**
	63B5	95	115	140	11	•	•	•	•	•	•	•	•	•	**	**	**
030	63B14	60	75	90	11	•	•	•	•	•	•	•	•	•	**	**	**
	56B5	80	100	120	9	•	•	•	•	•	•	•	•	•	•	•	**
040	56B14	50	65	80	9	•	•	•	•	•	•	•	•	•	•	•	**
	71B5	110	130	160	14	•	•	•	•	•	•	•	•	**	**	**	**
040	71B14	70	85	105	14	•	•	•	•	•	•	•	•	•	•	•	•
	63B5	95	115	140	11	•	•	•	•	•	•	•	•	•	•	•	•
050	63B14	60	75	90	11	•	•	•	•	•	•	•	•	•	•	•	•
	56B5	80	100	120	9	**	**	**	**	**	**	**	**	•	•	•	•
050	80B5	130	165	200	19	•	•	•	•	•	•	•	**	**	**	**	**
	80B14	80	100	120	19	•	•	•	•	•	•	•	**	**	**	**	**
050	71B5	110	130	160	14	•	•	•	•	•	•	•	•	•	•	•	**
	71B14	70	85	105	14	•	•	•	•	•	•	•	•	•	•	•	**
063	63B5	95	115	140	11	**	**	**	**	**	**	**	•	•	•	•	•
	90B5	130	165	200	24	**	•	•	•	•	•	•	•	+	+	+	+
063	90B14	95	115	140	24	**	•	•	•	•	•	•	•	+	+	+	+
	80B5	130	165	200	19	**	•	•	•	•	•	•	•	•	•	•	+
063	80B14	80	100	120	19	**	•	•	•	•	•	•	•	•	•	•	•
	71B5	110	130	160	14	**	•	•	•	•	•	•	•	•	•	•	•
075	71B14	70	85	105	14	**	•	•	•	•	•	•	•	•	•	•	•
	100/112B5	180	215	250	28	**	•	•	•	•	•	•	•	+	+	+	+
075	100/112B14	110	130	160	28	**	•	•	•	•	•	•	•	+	+	+	+
	90B5	130	165	200	24	**	•	•	•	•	•	•	•	•	•	+	+
075	90B14	95	115	140	24	**	•	•	•	•	•	•	•	•	•	•	•
	80B5	130	165	200	19	**	•	•	•	•	•	•	•	•	•	•	•
090	80B14	80	100	120	19	**	•	•	•	•	•	•	•	•	•	•	•
	71B5	110	130	160	14	**	•	•	•	•	•	•	•	•	•	•	•
090	71B14	70	85	105	14	**	•	•	•	•	•	•	•	•	•	•	•
	100/112B5	180	215	250	28	**	•	•	•	•	•	•	•	+	+	+	+
090	100/112B14	110	130	160	28	**	•	•	•	•	•	•	•	+	+	+	+
	90B5	130	165	200	24	**	•	•	•	•	•	•	•	•	•	•	+
110	90B14	95	115	140	24	**	•	•	•	•	•	•	•	•	•	•	•
	80B5	130	165	200	19	**	•	•	•	•	•	•	•	•	•	•	•
110	80B14	80	100	120	19	**	•	•	•	•	•	•	•	•	•	•	•
	132B5	230	265	300	38	**	**	**	**	•	•	•	•	+	+	+	+
110	100/112B5	180	215	250	28	**	**	**	**	•	•	•	•	•	•	+	+
	100/112B14	110	130	160	28	**	**	**	**	•	•	•	•	•	•	+	+
130	90B5	130	165	200	24	**	**	**	**	•	•	•	•	•	•	•	•
	80B5	130	165	200	19	**	**	**	**	•	•	•	•	•	•	•	•
130	80B14	80	100	120	19	**	**	**	**	•	•	•	•	•	•	•	•
	132B5	230	265	300	38	**	**	**	**	**	**	**	**	**	**	**	**
150	100/112B5	180	215	250	28	**	**	**	**	**	**	**	**	•	•	•	•
	90B5	130	165	200	24	**	**	**	**	**	**	**	**	**	**	•	•
150	160B5	250	300	350	42	**	**	**	**	**	**	**	**	**	**	**	**
	132B5	230	265	300	38	**	**	**	**	**	**	**	**	**	•	**	**
150	100/112B5	180	215	250	28	**	**	**	**	**	**	**	**	**	•	•	•

2.9.2 NMRV - NMRV-P HYBRID Motor flange availability

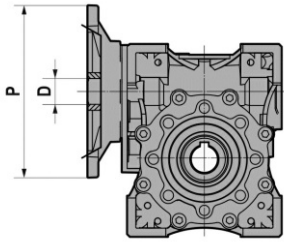

- (*) Low profile key supplied by Motovario.
- (**) For NMRV-P 110 flange Ø300 only possible solution bush Ø38.
- (+) Motor-ratio combination not to be used, out of warranty terms.

The table report possible configurations strictly based on geometric criteria. To determine the compatibility of a motor-gear unit assembly in terms of mechanical factors, double check the selected configuration against the rating charts for NRV/NRV-P performances.

NMRV NMRV-P	P	i											
		5	7,5	10	15	20	25	30	40	50	60	80	100
D													
025	80	9	9	9	9	9	-	9	9	9	9	-	-
030	140												
	120	11	11	11	11	11	11	11	11	11	9	9	-
	90	9	9	9	9	9	9	9	9	9	9	9	-
040	80												
	160												
	140												
	120	14	14	14	14	14	14	14	14	14	11	11	11
050	105	11	11	11	11	11	11	11	11	11	9	9	9
	90												
	200												
	160	19	19	19	19	19	19	19	14	14	14	14	11
	140	14	14	14	14	14	14	14	11	11	11	11	11
063	120												
	105												
	200												
	160		24	24	24	24	24	24	24	19	19	19	14
	140	-	19	19	19	19	19	19	19	14	14	14	14
075	120												
	105												
	250												
	200												
	160	-	28	28	28	28	28	28	24	24	24	19	19
	140		24	24	24	24	24	24	19	19	19	14	14
090	120												
	105												
	250												
	200												
	160	-	28	28	28	28	28	28	28	24	24	24	19
110	140												
	120												
	300		38**	38**	38**	38**	38**	38**	38**	+	+	+	+
	250												
	200												
130	160												
	350												
	250												
	200	-	38*	38*	38*	38*	38*	38*	38*	28	28	28	28
150	160												
	350												
	300												
150	250	-	42	42	42	42	42	38	38	38	38	28	28
	250												

2.9.3 HA31+NMRV Motor flange availability

HA31	NMRV 040	flx12	63	71	80
2,94	7,5	22,08	B5	B5	B5
4,75	5	23,75	B5	B5	B5
5,10	5	25,50	B5	B5	
2,94	10	29,44	B5	B5	
6,30	5	31,50	B5	B5	
4,75	7,5	35,63	B5	B5	
5,45	7,5	40,91	B5	B5	
2,94	15	44,17	B5	B5	
4,75	10	47,50	B5	B5	
5,45	10	54,55	B5	B5	
2,94	20	58,89	B5	B5	
6,30	10	63,00	B5	B5	
4,75	15	71,25	B5	B5	
7,88	10	78,75	B5		
2,94	30	88,33	B5		
6,30	15	94,50	B5		
5,10	20	102,00	B5		
5,45	20	109,09	B5		
7,88	15	118,13	B5		
5,10	25	127,50	B5		
4,75	30	142,50	B5		
3,87	40	154,67	B5		
5,45	30	163,64	B5		
6,30	30	189,00	B5		
5,10	40	204,00	B5		

HA31	NMRV 050	flx12	63	71	80
2,94	7,5	22,08		B5	B5
4,75	5	23,75	B5	B5	B5
5,10	5	25,50	B5	B5	
2,94	10	29,44	B5	B5	B5
6,30	5	31,50	B5	B5	
4,75	7,5	35,63	B5	B5	B5
5,45	7,5	40,91	B5	B5	
2,94	15	44,17	B5	B5	B5
4,75	10	47,50	B5	B5	B5
5,45	10	54,55	B5	B5	
2,94	20	58,89	B5	B5	
6,30	10	63,00	B5	B5	
4,75	15	71,25	B5	B5	
7,88	10	78,75	B5	B5	
2,94	30	88,33	B5	B5	
6,30	15	94,50	B5	B5	
5,10	20	102,00	B5	B5	
5,45	20	109,09	B5	B5	
7,88	15	118,13	B5	B5	
5,10	25	127,50	B5	B5	
4,75	30	142,50	B5	B5	
3,87	40	154,67	B5	B5	
5,45	30	163,64	B5	B5	
6,30	30	189,00	B5		
5,10	40	204,00	B5		
7,88	30	236,25	B5		
6,30	40	252,00	B5		
5,45	50	272,73	B5		
4,75	60	285,00	B5		
6,30	50	315,00	B5		

2.9.4 NMRV-P/HW Motor flange availability

HW030	NMRV-P 063	i/xi2	56	63	71	80
2,94	7,5	22,08			B5-B14	B5-B14
3,86	7,5	29,00			B5-B14	B5-B14
3,86	10	38,67			B5-B14	B5-B14
2,94	15	44,17			B5-B14	B5-B14
4,75	10	47,50		B5	B5-B14	B5-B14
3,86	15	58,00		B5	B5-B14	B5-B14
4,75	15	71,25		B5	B5-B14	B5-B14
3,86	20	77,33		B5	B5-B14	B5-B14
5,45	15	81,82		B5	B5-B14	B5-B14
2,94	30	88,33		B5	B5-B14	B5-B14
4,75	20	95,00		B5	B5-B14	B5-B14
5,45	20	109,09		B5	B5-B14	B5-B14
7,88	15	118,13		B5	B5-B14	B5-B14
5,45	25	136,36		B5	B5-B14	B5-B14
4,75	30	142,50		B5	B5-B14	B5-B14
7,88	20	157,50		B5	B5-B14	B5-B14
5,45	30	163,64		B5	B5-B14	B5-B14
2,94	60	176,67	B5	B5	B5-B14	
7,88	25	196,88	B5	B5	B5-B14	
5,45	40	218,18	B5	B5	B5-B14	
7,88	30	236,25	B5	B5	B5-B14	
5,45	50	272,73	B5	B5	B5-B14	
7,88	40	315,00	B5	B5	B5-B14	
7,88	50	393,75	B5	B5	B5-B14	
10,83	40	433,33	B5	B5		
7,88	60	472,50	B5	B5		
10,83	50	541,67	B5	B5		
10,83	60	650,00	B5	B5		
7,88	100	787,50	B5			
10,83	80	866,67	B5			
10,83	100	1083,33	B5			

HW030	NMRV-P 075	i	56	63	71	80
2,94	7,5	22,08				B5-B14
3,86	7,5	29,00			B5-B14	B5-B14
3,86	10	38,67			B5-B14	B5-B14
2,94	15	44,17			B5-B14	B5-B14
4,75	10	47,50			B5-B14	B5-B14
3,86	15	58,00			B5-B14	B5-B14
4,75	15	71,25			B5-B14	B5-B14
3,86	20	77,33			B5-B14	B5-B14
5,45	15	81,82		B5	B5-B14	B5-B14
2,94	30	88,33		B5	B5-B14	B5-B14
4,75	20	95,00		B5	B5-B14	B5-B14
5,45	20	109,09		B5	B5-B14	B5-B14
7,88	15	116,00		B5	B5-B14	B5-B14
5,45	25	136,36		B5	B5-B14	B5-B14
4,75	30	142,50		B5	B5-B14	B5-B14
7,88	20	154,67		B5	B5-B14	B5-B14
5,45	30	163,64		B5	B5-B14	B5-B14
2,94	60	176,67		B5	B5-B14	B5-B14
7,88	25	196,88		B5	B5-B14	B5-B14
5,45	40	218,18		B5	B5-B14	B5-B14
7,88	30	236,25		B5	B5-B14	B5-B14
5,45	50	272,73		B5	B5-B14	B5-B14
7,88	40	315,00		B5	B5-B14	
7,88	50	393,75	B5	B5	B5-B14	
7,88	60	472,50	B5	B5	B5-B14	
10,83	50	541,67	B5	B5		
10,83	60	650,00	B5	B5		
7,88	100	787,50	B5	B5		
10,83	80	866,67	B5	B5		
10,83	100	1083,33	B5			

HW040	NMRV-P 090	i	63	71	80	90
3,11	7,5	23,29			B5-B14	B5-B14
3,11	10	31,05			B5-B14	B5-B14
4,20	10	42,00			B5-B14	B5-B14
3,11	15	46,58			B5-B14	B5-B14
4,20	15	63,00		B5-B14	B5-B14	B5-B14
3,11	25	77,63		B5-B14	B5-B14	B5-B14
4,20	20	84,00		B5-B14	B5-B14	B5-B14
3,11	30	93,16		B5-B14	B5-B14	B5-B14
5,50	20	110,00		B5-B14	B5-B14	B5-B14
4,20	30	126,00		B5-B14	B5-B14	B5-B14
5,50	25	137,50		B5-B14	B5-B14	B5-B14
3,11	50	155,26	B5	B5-B14	B5-B14	B5-B14
5,50	30	165,00		B5-B14	B5-B14	B5-B14
3,11	60	186,32	B5	B5-B14	B5-B14	
5,50	40	220,00	B5	B5-B14	B5-B14	B5-B14
4,20	60	252,00	B5	B5-B14	B5-B14	
5,50	50	275,00	B5	B5-B14	B5-B14	
6,09	50	304,55	B5	B5-B14	B5-B14	
5,50	60	330,00	B5	B5-B14	B5-B14	
7,67	50	383,33	B5	B5-B14	B5-B14	
8,75	50	437,50	B5	B5-B14		
7,67	60	460,00	B5	B5-B14		
8,75	60	525,00	B5	B5-B14		
7,67	80	613,33	B5	B5-B14		
8,75	80	700,00	B5	B5-B14		
7,67	100	766,67	B5			
8,75	100	875,00	B5			

HW040	NMRV-P 110	i	63	71	80	90
3,11	7,5	23,29			B5-B14	B5-B14
3,11	10	31,05			B5-B14	B5-B14
4,20	10	42,00			B5-B14	B5-B14
3,11	15	46,58			B5-B14	B5-B14
3,105	20	62,11			B5-B14	B5-B14
3,11	25	77,63			B5-B14	B5-B14
4,20	20	84,00			B5-B14	B5-B14
3,11	30	93,16			B5-B14	B5-B14
4,200	25	105,00			B5-B14	B5-B14
4,20	30	126,00			B5-B14	B5-B14
5,50	25	137,50		B5-B14	B5-B14	B5-B14
3,11	50	155,26		B5-B14	B5-B14	B5-B14
4,200	40	168,00		B5-B14	B5-B14	B5-B14
3,11	60	186,32		B5-B14	B5-B14	B5-B14
5,50	40	220,00		B5-B14	B5-B14	B5-B14
4,20	60	252,00		B5-B14	B5-B14	B5-B14
5,50	50	275,00		B5-B14	B5-B14	B5-B14
6,09	50	304,55	B5	B5-B14	B5-B14	B5-B14
5,50	60	330,00	B5	B5-B14	B5-B14	
7,67	50	383,33	B5	B5-B14	B5-B14	
5,500	80	440,00	B5	B5-B14	B5-B14	
7,67	60	460,00	B5	B5-B14	B5-B14	
8,75	60	525,00	B5	B5-B14		
7,67	80	613,33	B5	B5-B14	B5-B14	
8,75	80	700,00	B5	B5-B14		
7,67	100	766,67	B5	B5-B14		
8,75	100	875,00	B5	B5-B14		

2.9.5 Ratios NRV/NMRV/NMRV-P+NMRV/NMRV-P

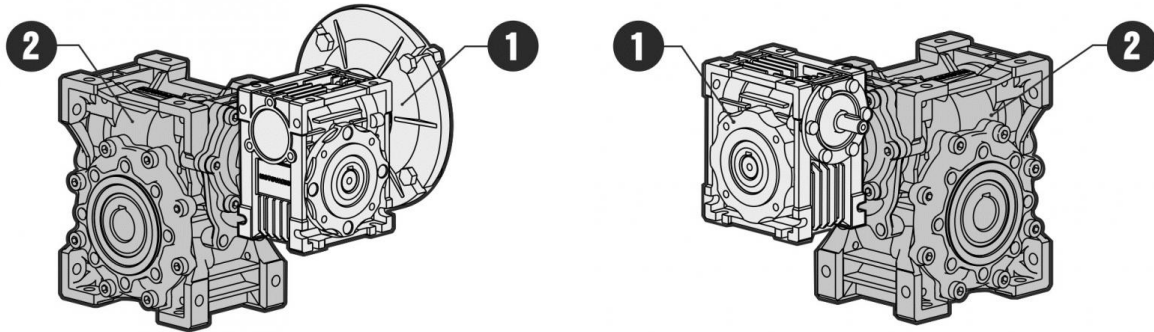

i	NMRV/NMRV	i1	i2
100	025/030	10	10
150		7.5	20
200		10	20
250		10	25
300		10	30
400		20	20
500		20	25
600		20	30
750		30	25
900		15	60
1200		30	40
1500		30	50
1800		60	30
2400		60	40
3000		60	50
4000		50	80

i	NMRV/NMRV	i1	i2
100	025/040	10	10
150		7.5	20
200		10	20
250		10	25
300		10	30
400		20	20
500		20	25
600		20	30
750		30	25
900		30	30
1200		30	40
1500		30	50
1800		60	30
2400		60	40
3000		60	50
4000		50	80
5000	50	100	

i	NMRV/NMRV NRV/NMRV	i1	i2
100	030/040	10	10
150		10	15
200		10	20
250		10	25
300		10	30
400		10	40
500		20	25
600		20	30
750		25	30
900		30	30
1200		40	30
1500		50	30
1800		60	30
2400		60	40
3000		60	50
4000		50	80
5000	50	100	

i	NMRV/NMRV NRV/NMRV	i1	i2
100	030/050	10	10
150		10	15
200		10	20
250		10	25
300		10	30
400		10	40
500		10	50
600		20	30
750		25	30
900		30	30
1200		40	30
1500		50	30
1800		60	30
2400		60	40
3000		60	50
4000		50	80
5000	50	100	

i	NMRV/NMRV-P NRV/NMRV-P	i1	i2
100	030/063	10	10
150		10	15
200		10	20
250		10	25
300		7.5	40
400		10	40
500		10	50
600		20	30
750		25	30
900		30	30
1200		40	30
1500		50	30
1800		60	30
2400		60	40
3000		60	50
4000		80	50
5000	50	100	

i	NMRV/NMRV NRV/NMRV	i1	i2
100	040/050	10	10
150		10	15
200		10	20
250		10	25
300		10	30
400		10	40
500		50	10
600		20	30
750		25	30
900		60	15
1200		40	30
1500		50	30
1800		60	30
2400		60	40
3000		60	50
4000		80	50
5000	100	50	

2.9 MOTOR FLANGE AVAILABILITY

i	NMRV/NMRV-P NRV/NMRV-P	i1	i2
100	040/063	10	10
150		10	15
200		10	20
250		10	25
300		10	30
400		10	40
500		20	25
600		20	30
750		25	30
900		30	30
1200		40	30
1500		50	30
1800		60	30
2400		60	40
3000		60	50
4000		80	50
5000	100	50	

i	NMRV/NMRV-P NRV/NMRV-P	i1	i2
100	040/075	10	10
150		10	15
200		10	20
250		10	25
300		10	30
400		10	40
500		10	50
600		20	30
750		25	30
900		30	30
1200		40	30
1500		50	30
1800		60	30
2400		60	40
3000		60	50
4000		80	50
5000	100	50	

i	NMRV/NMRV-P NRV/NMRV-P	i1	i2
100	040/090	10	10
150		10	15
200		10	20
250		10	25
300		10	30
400		10	40
500		10	50
600		20	30
750		25	30
900		30	30
1200		40	30
1500		50	30
1800		60	30
2400		60	40
3000		60	50
4000		80	50
5000	100	50	

i	NMRV/NMRV-P NRV/NMRV-P	i1	i2
100	050/090	10	10
150		10	15
200		10	20
250		10	25
300		10	30
400		10	40
500		20	25
600		20	30
750		25	30
900		30	30
1200		40	30
1500		50	30
1800		60	30
2400		60	40
3000		60	50
4000		80	50
5000	100	50	

i	NMRV/NMRV-P NRV/NMRV-P	i1	i2
100	050/110	10	10
150		10	15
200		10	20
250		10	25
300		10	30
400		10	40
500		20	25
600		20	30
750		25	30
900		30	30
1200		40	30
1500		50	30
1800		60	30
2400		60	40
3000		60	50
4000		80	50
5000	100	50	

i	NMRV-P/NMRV-P NRV-P/NMRV-P	i1	i2
100	063/110	10	10
150		10	15
200		10	20
250		10	25
300		10	30
400		10	40
500		20	25
600		20	30
750		25	30
900		30	30
1200		40	30
1500		50	30
1800		60	30
2400		60	40
3000		60	50
4000		80	50
5000	100	50	

i	NMRV-P/NMRV NRV-P/NMRV	i1	i2
100	063/130	10	10
150		10	15
200		10	20
250		10	25
300		10	30
400		10	40
500		10	50
600		20	30
750		25	30
900		30	30
1200		40	30
1500		50	30
1800		60	30
2400		60	40
3000		60	50
4000		80	50
5000	100	50	

i	NMRV-P/NMRV NRV-P/NMRV	i1	i2
150	063/150	7.5	20
200		10	20
250		10	25
300		15	20
400		10	40
500		10	50
600		15	40
750		15	50
900		30	30
1200		30	40
1500		30	50
1800		60	30
2400		60	40
3000		60	50
4000		80	50
5000		100	50

VSF		Standard	On request
NMRV	025	1	/
NMRV	030	1	/
NMRV	040	1	2
NMRV	050	1	2
NMRV-P	063	1	2
NMRV-P	075	1	2
NMRV-P	090	1	2
NMRV-P	110	1	2
NMRV	130	1	2
NMRV	150	1	2

1 - Ball Bearing

2 - Roller bearings

/ - Not available

2.11.1 Information

The value of the admissible radial load [N] is given in the tables relating to the performance of the gear reducer at issue. It is related to the load applied on the centre line of the shaft and in the most unfavourable conditions of angle of application and direction of rotation. The maximum admissible axial loads are 1/5 of the value of the given radial load when they are applied in combination with the radial load. The tables relating to the output shafts give the maximum admissible value. This value must never be exceeded since it relates to the strength of the case. Particular conditions of radial load higher than the limits of the catalogue may occur. In this case, call our Technical Service and provide details on the application: direction of the load, direction of rotation of the shaft, type of service. In case of double extension shafts with radial load applied on both ends, the max. admissible radial loads must be defined according to the specific running conditions, in this case call our Technical Service. The radial load on the shaft is calculated with the following formula:

$$Fr_e = (2000 \cdot M \cdot f_z) / D \leq Fr_1 \text{ or } Fr_2$$

- **Fr_e** [N] Resulting radial load
- **M** [Nm] Torque on the shaft
- **D** [mm] Diameter of the transmission member mounted on the shaft
- **Fr₁-Fr₂** [N] Value of the maximum admitted radial load (see relative tables)
- **f_z** = 1,1 gear pinion - 1,4 chain wheel - 1,7 v-pulley - 2,5 flat pulley

2.11.2 Input

When the radial load is not on the center line of the shaft, it is necessary to adjust the admissible radial load Fr₁ with the following formula: $Fr_x = (Fr_1 \cdot a) / (b + x)$

- **a**, **b** = values given in the tables
- **x** = distance from the point of application of the load to the shaft shoulder

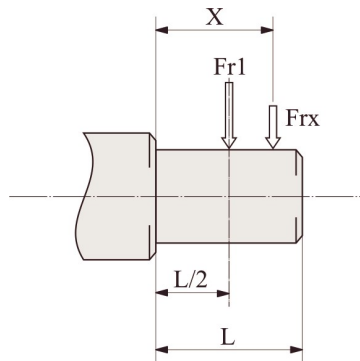

NRV/NRV-P	030	040	050	063	075	090	110	130	150
a	86	106	129	159	192	227	266	314	350
b	76	94,5	114	139	167	202	236	274	310
Fr ₁ max(**)	210	350	490	700	980	1270	1700	2100	2800

IHW040	090	110
a	71	71
b	51	51
Fr ₁ max(**)	400	500

(**Fr₁ max) Max admissible value of the reducer in static conditions and/or for limited operations. For continuous overhung loads please check the values on the performances tables calculated according to the casing, the shaft and bearings.

2.11.3 Output

When the radial load is not on the centre line of the shaft, it is necessary to adjust the admissible radial load Fr_2 with the following formula: $Fr_x = (Fr_2 \cdot a) / (b + x)$

- a, b = values given in the tables
- x = distance from the point of application of the load to the shaft shoulder

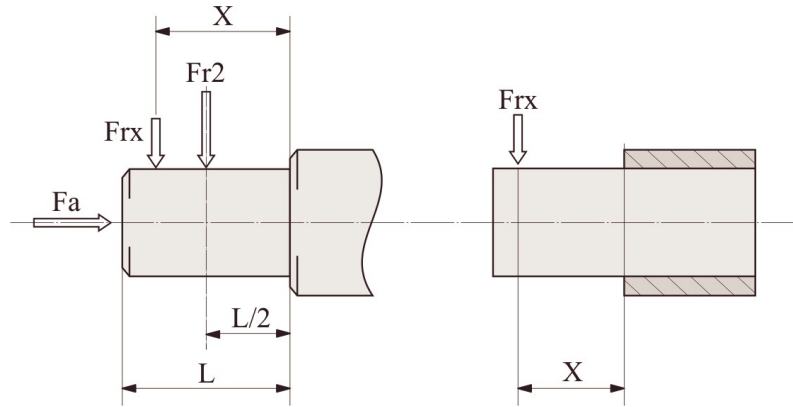

NMRV NMRV-P	025	030	040	050	063	075	090	110	130	150
a	50	65	84	101	120	131	162	176	188	215
b	38	50	64	76	95	101	122	136	148	174
Fr2 max(**)	1350	1830	3490	4840	6270	7380	8180	12000	13500	18000

(**Fr2 max) Max admissible value of the reducer in static conditions and/or for limited operations. For continuous overhung loads please check the values on the performances tables calculated according to the casing, the shaft and bearings.

2.12.1 Information

In cases of ambient temperatures not envisaged in the table, call our Technical Service. In the case of temperatures under -30°C or over 60°C it is necessary to use oil seals with special properties. For operating ranges with temperatures under 0°C it is necessary to consider the following:

1. The motors need to be suitable for operation at the envisaged ambient temperature.
2. The power of the electric motor needs to be adequate for exceeding the higher starting torques required.
3. In case of cast-iron gear reducers, pay attention to impact loads since cast iron may have problems of fragility at temperatures under -15°C .
4. During the early stages of service, problems of lubrication may arise due to the high level of viscosity taken on by the oil and so it is wise to have a few minutes of rotation under no load.



For ATEX gear reducers:

- Change oil as specified in the "Maintenance" table of the relevant "Use and Installation Instructions" manual (supplied with products).
- The use of oils other than the original one is forbidden.

2.12.2 Lubricants

Specifications of lubricants recommended by Motovario.

All units are supplied with ENI oil, unless otherwise specified by the client.

	HA31	NMRV 025 ÷ 150 NMRV-P 063 ÷ 110 HW 030 ÷ 040
	Mineral oil	Synthetic oil
$T_{\text{amb}}^{\circ}\text{C}$ ISO	(-5) ÷ (+40) ISO VG220	(-25) ÷ (+50) ISO VG320
ENI	BLASIA 220	TELIUM VSF320
SHELL	OMALA OIL220	OMALA S4 WE320
KLUBER	Kluberoil GEM 1-220N	Klubersynth GH 6-320
MOBIL	MOBILGEAR 600 XP220	-
CASTROL	ALPHA SP 220	ALPHASYN PG320
BP	ENERGOL GR-XP220	ENERGOL SG-XP320
PETRONAS	GEAR MEP 220	GEAR SYN PAG 320

2.12.3 Special lubricants

	$T_{amb}^{\circ C}$	Polyglycol synthetic oil
ENI	(-30) ÷ (+30)	Blasia S 150 (ISO VG150)
	(-20) ÷ (+40)	Blasia S 220 (ISO VG220)
KLUBER	(-40) ÷ (+5)	Klubersynth GH 6-32 (ISO VG32)
	(-35) ÷ 10)	Klubersynth GH 6-80 (ISO VG80)
	(-30) ÷ (+40)	Klubersynth GH 6-150 (ISO VG150)
	(-25) ÷ (+40)	Klubersynth GH 6-220 (ISO VG220)
	(-15) ÷ (+50)	Klubersynth GH 6-460 (ISO VG460)
	(-10) ÷ (+70)	Klubersynth GH 6-680 (ISO VG680)
	$T_{amb}^{\circ C}$	Polyglycol synthetic oil for food grade
KLUBER	(-30) ÷ (+15)	Klubersynth UH1-6 100 (ISO VG100)
	(-25) ÷ (+40)	Klubersynth UH1-6 220 (ISO VG220)
	(-15) ÷ (+40)	Klubersynth UH1-6 320 (ISO VG320)
	(-15) ÷ (+50)	Klubersynth UH1-6 460 (ISO VG460)
	(-10) ÷ (+50)	Klubersynth UH1-6 680 (ISO VG680)

If 'special' lubricant is required please contact MOTOVARIO TECHNICAL SERVICE.

2.12.4 Quantity

- The gear reducers size 025 - 030 - 040 - 050 - 063 - 075 - 090 - 110 - 130 - 150 are supplied complete with lubricant for life, synthetic oil, ENI TELIUM VSF. They can be mounted in any position envisaged in the catalogue, except for NMRV 090 - 110 and NRV 075-090-110 for which you must to specify the mounting position.
- For sizes 130 and 150 it is necessary to specify the position, otherwise the gear reducers are supplied with the quantity of oil relating to pos. B3.
- Only reduction units 130 and 150 are fitted with breather, level and oil drainage plugs.
- The pre-stage helical modules are supplied complete with life-long lubricant, synthetic oil, ENI TELIUM VSF. Lubrication is separated from that of the worm gear reducers.

It is recommended, after installation, to replace the closed plug used for transportation with the supplied breather plug.

Quantity of oil in litres -

NMRV	025	030	040	050	130	150
B3	0,02	0,04	0,08	0,15	4,5	7
B8					3,3	5,1
B6-B7					3,5	5,4
V5					4,5	7
V6					3,3	5,1

NMRV-P	063	075	090	110
B3	0,33	0,55	1,15	1,6
B8				
B6-B7				
V5				
V6				

HW	HW030		HW040	
	NMRV-P063	NMRV-P075	NMRV-P090	NMRV-P110
B3-B6-B7-B8-V5-V6	0,06	0,09	0,11	0,12

H	A31
B3-B5	0,07

The following values of J1 moment of inertia are only estimated, referred to the maximum calculated, and to the gearbox input side.

NMRV	J ₁ [Kg*m ²]
025	0,000003
030	0,00001
040	0,00003
050	0,0001
130	0,0022
150	0,0053

HA-1	J ₁ [Kg*m ²]
A31	0,0001

NMRV-P	J ₁ [Kg*m ²]
063	0,0002
075	0,0004
090	0,0008
110	0,0020

3.1.1 NMRV 025

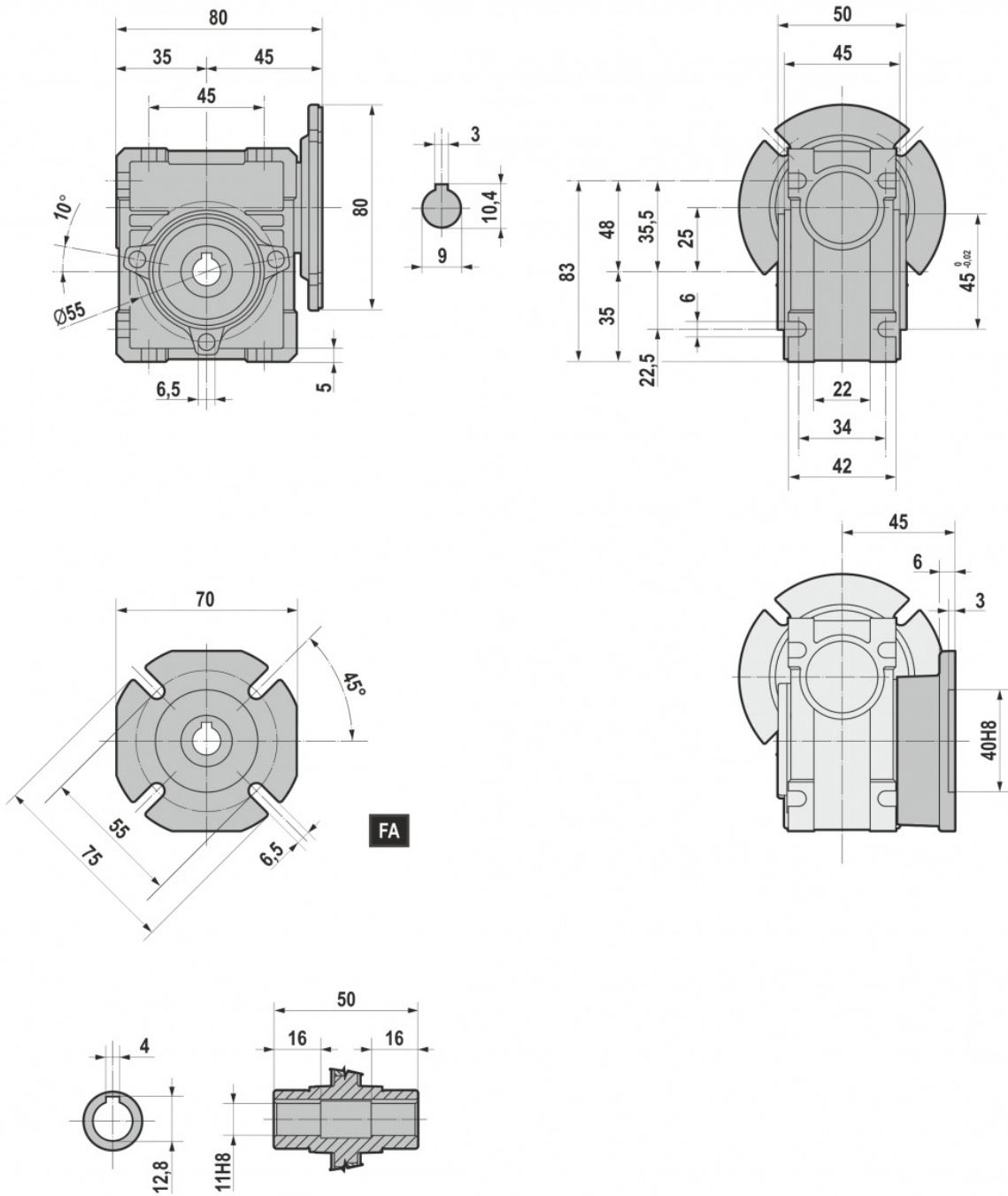

3.1.2 NMRV 030-150

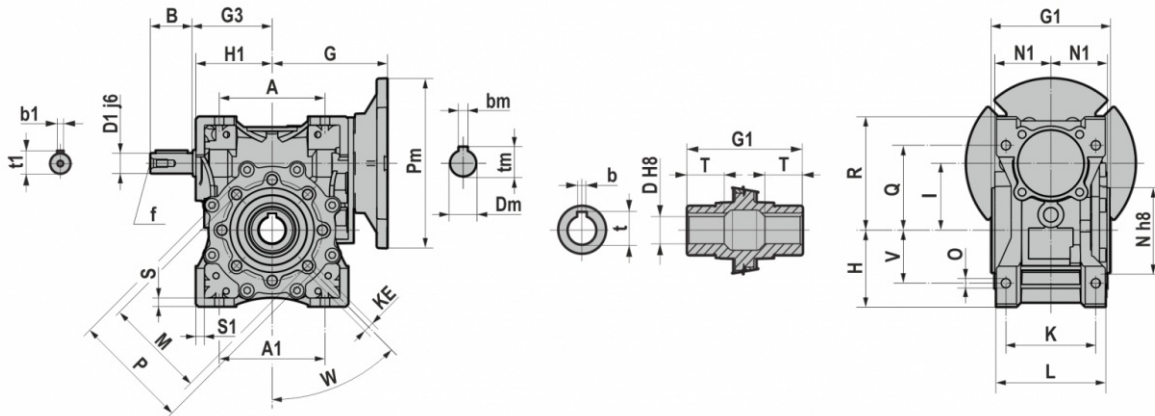

	030	040	050	063	075	090	110	130	150
A	54	70	80	100	120	140	170	200	240
A1	54	70	80	100	120	140	164 - 170	200	240
B	20	23	30	40	50	50	60	80	80
D1 j6	9	11	14	19	24	24	28	30	35
G	55	70	80	109	126,5	145	185,5 (PAM 132) 168 (PAM 080/112)	180	210
G1	63	78	92	112	120	140	155	170	200
G3	45	53	64	75	90	108	135	155	175
H	40	50	60	72	86	103	127,5	147,5	170
H1	40	50	60	72	89	103	127,5	147,5	170
I	30	40	50	63	75	90	110	130	150
K	44	60	70	85	90 - 95	100	115	120	145
KE	M6*11	M6*11	M8*10	M8*14	M8*14	M10*18	M10*18	M12*21	M12*21
L	56	71	85	103	112	130	144	155	185
M	65	75	85	95	115	130	165	215	215
N	55	60	70	80	95	110	130	180	180
N1	29	36,5	43,5	53	57	67	74	81	96
O	6,5	6,5	8,5	8,5	11	13	14	16	18
P	75	87	100	110	131	160	200	250	250
Q	44	55	64	80	93	102	125	140	180
R	57	71,5	84	107	123	144	167,5	187,5	230
S	5,5	6,5	7	8	10	11	14,5	15,5	18
S1	5,5	6,5	7	8	13	11	14,5	15,5	18
V	27	35	40	50	60	70	82 - 85	100	120
W	0	45	45	45	45	45	45	45	45
b1	3	4	5	6	8	8	8	8	10
t1	10,2	12,5	16	21,5	27	27	31	33	38
f1	-	-	M6	M6	M8	M8	M10	M10	M12

	D H8	b	t	T
030	14	5	16,3	21
040	18	6	20,8	26
	19	6	21,8	26
050	25	8	28,3	30
	24	8	27,3	30
063	25	8	28,3	36
	28	8	31,3	36
075	28	8	31,3	40
	30	8	33,3	40
	32	10	35,3	40
090	35	10	38,3	40
	35	10	38,3	45
	38	10	41,3	45
110	42	12	45,3	50
130	45	14	48,8	60
150	50	14	53,8	72,5

B5	Pm	Dm	bm	tm
063	140	11	4	12,8
071	160	14	5	16,3
080	200	19	6	21,8
090	200	24	8	27,3
100	250	28	8	31,3
112	250	28	8	31,3
132	300	38	10	41,3
160	350	42	12	45,3

B14	Pm	Dm	bm	tm
056	80	09	3	10,4
063	90	11	4	12,8
071	105	14	5	16,3
080	120	19	6	21,8
090	140	24	8	27,3
100	160	28	8	31,3
112	160	28	8	31,3

3.1.3 NRV

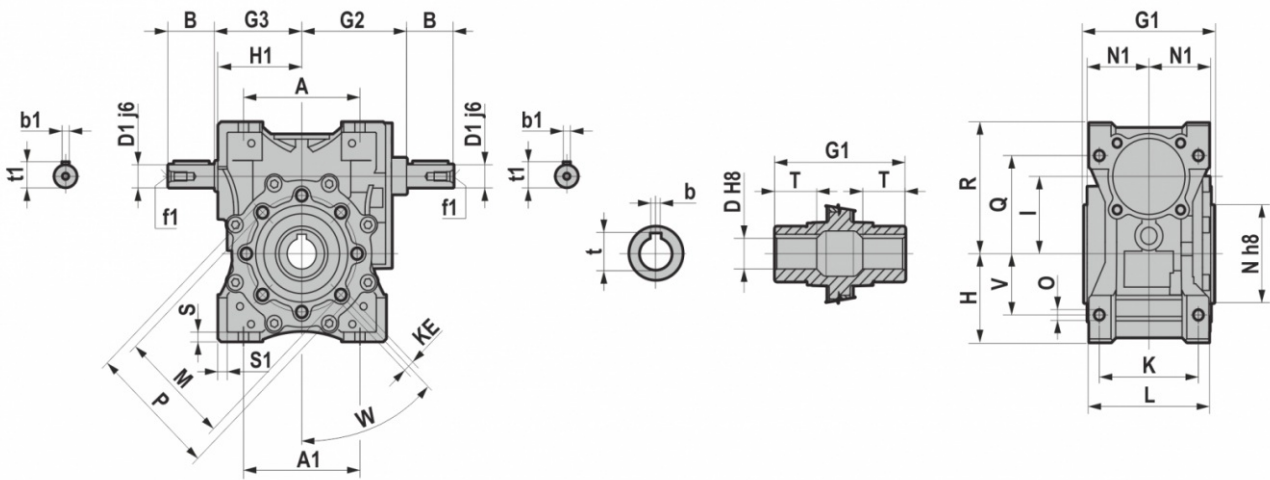

	030	040	050	063	075	090	110	130	150
A	54	70	80	100	120	140	170	200	240
A1	54	70	80	100	120	140	164 - 170	200	240
B	20	23	30	40	50	50	60	80	80
D1 j6	9	11	14	19	24	24	28	30	35
G1	63	78	92	112	120	140	155	170	200
G2	51	60	74	90	105	125	142	162	195
G3	45	53	64	75	90	108	135	155	175
H	40	50	60	72	86	103	127,5	147,5	170
H1	40	50	60	72	89	103	127,5	147,5	170
I	30	40	50	63	75	90	110	130	150
K	44	60	70	85	90 - 95	100	115	120	145
KE	M6*11	M6*11	M8*10	M8*14	M8*14	M10*18	M10*18	M12*21	M12*21
L	56	71	85	103	112	130	144	155	185
M	65	75	85	95	115	130	165	215	215
N	55	60	70	80	95	110	130	180	180
N1	29	36,5	43,5	53	57	67	74	81	96
O	6,5	6,5	8,5	8,5	11	13	14	16	18
P	75	87	100	110	131	160	200	250	250
Q	44	55	64	80	93	102	125	140	180
R	57	71,5	84	107	123	144	167,5	187,5	230
S	5,5	6,5	7	8	10	11	14,5	15,5	18
S1	5,5	6,5	7	8	13	11	14,5	15,5	18
V	27	35	40	50	60	70	82 - 85	100	120
W	0	45	45	45	45	45	45	45	45
b1	3	4	5	6	8	8	8	8	10
t1	10,2	12,5	16	21,5	27	27	31	33	38
f1	-	-	M6	M6	M8	M8	M10	M10	M12

	D H8	b	t	T
030	14	5	16,3	21
040	18	6	20,8	26
	19	6	21,8	26
050	25	8	28,3	30
	24	8	27,3	30
063	25	8	28,3	36
	28	8	31,3	36
075	28	8	31,3	40
	30	8	33,3	40
	32	10	35,3	40
090	35	10	38,3	40
	35	10	38,3	45
	40	12	43,3	45
110	42	12	45,3	50
130	45	14	48,8	60
150	50	14	53,8	72,5

3.1.4 HA31+NMRV

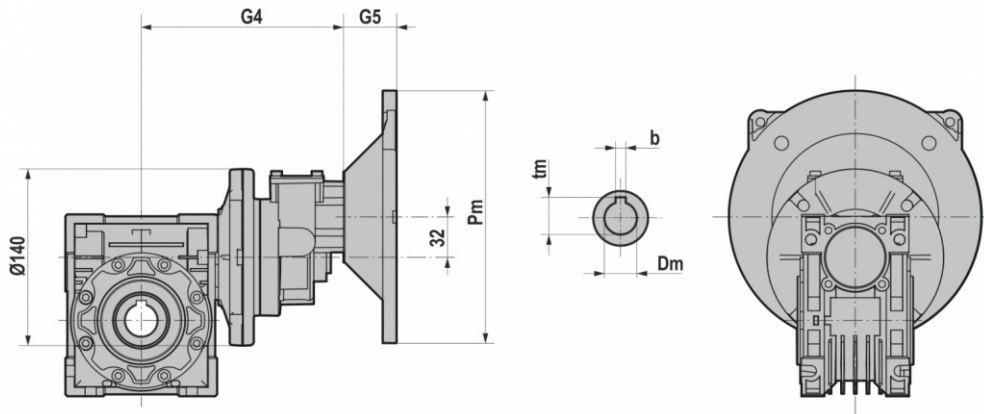

	NMRV040		NMRV050	
	G4	G5	G4	G5
063	150	25	160	25
071	150	32	160	32
080	150	42	160	42

B5	Pm	Dm	bm	tm
063	140	11	4	12,8
071	160	14	5	16,3
080	200	19	6	21,8

3.1.5 NMRV-P/HW

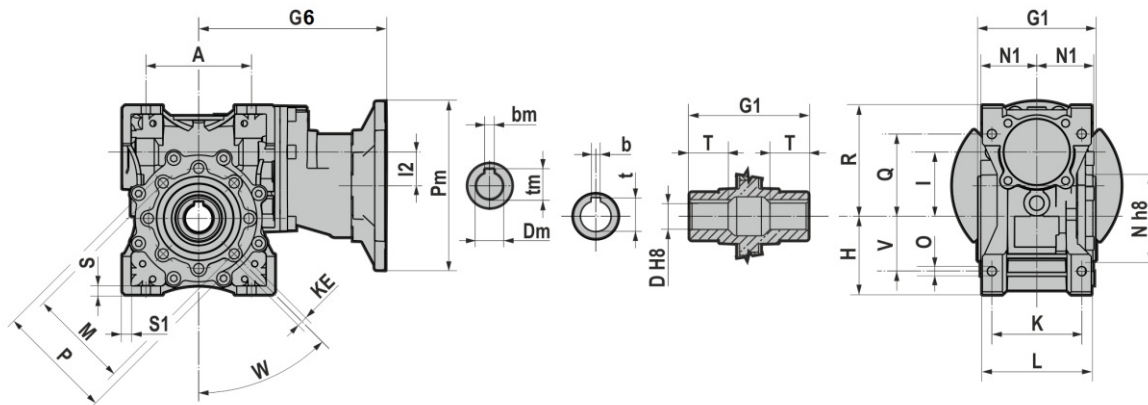

	HW030		HW040	
	056/063/071/080		063/071/080/090	
	NMRV-P 063	NMRV-P 075	NMRV-P 090	NMRV-P 110
A	100	120	140	170
G1	112	120	140	155
G6	176,5	194	218	241
H	72	86	103	127,5
H1	72	89	103	127,5
I	63	75	90	110
I2	32	32	42	42
K	85	90 - 95	100	115
KE	M8*14	M8*14	M10*18	M10*18
L	103	112	130	144
M	95	115	130	165
N	80	95	110	130
N1	53	57	67	74
O	8,5	11	13	14
P	110	131	160	200
Q	80	93	102	125
R	107	123	144	167,5
S	8	10	11	14,5
S1	8	13	11	14,5
V	50	60	70	82 - 85
W	45	45	45	45

NMRV-P	D H8	b	t	T
063	25	8	28,3	36
	28	8	31,3	36
075	28	8	31,3	40
	30	8	33,3	40
	32	10	35,3	40
	35	10	38,3	40
090	35	10	38,3	45
	38	10	41,3	45
	40	12	43,3	45
110	42	12	45,3	50

B5	Pm	Dm	bm	tm
056	120	09	3	10,4
063	140	11	4	12,8
071	160	14	5	16,3
080	200	19	6	21,8
090	200	24	8	27,3

B14	Pm	Dm	bm	tm
056	80	09	3	10,4
063	90	11	4	12,8
071	105	14	5	16,3
080	120	19	6	21,8
090	140	24	8	27,3

3.1.6 NMRV-P/IHW

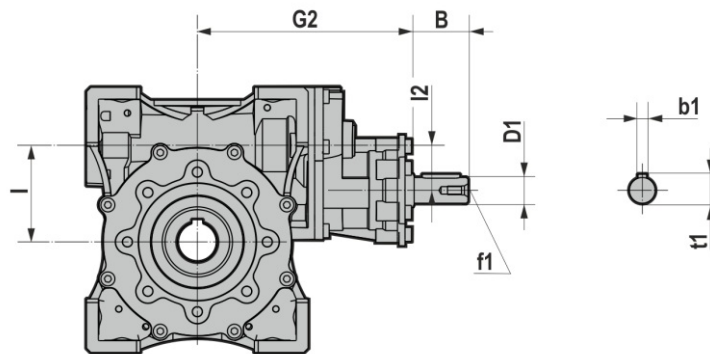

IHW040		
	NMRV-P 090	NMRV-P 110
I	90	110
G2	204,5	227,5
I2	42	42
B	40	50
D1	19 j6	24 j6
b1	6	8
t1	21,5	27
f1	M6	M8

3.1.7 NMRV/NMRV-P+NMRV/NMRV-P

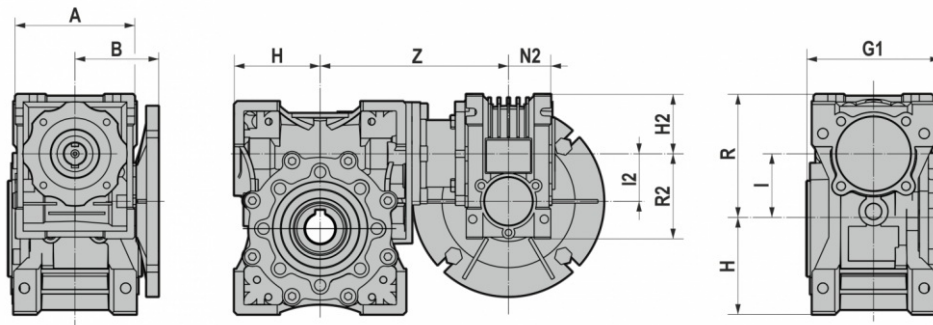

	A	G	G1	H	H1	I	R	H2	I2	N2	R2	Z
025-030	70	45	63	40	40	30	57	35	25	22,5	48	100
025-040	70	45	78	50	50	40	71,5	35	25	22,5	48	115
030-040	80	55	78	50	50	40	71,5	40	30	29	57	122
030-050	80	55	92	60	60	50	84	40	30	29	57	132
030-063	80	55	112	72	72	63	107	40	30	29	57	145
040-050	100	70	92	60	60	50	84	50	40	36,5	71,5	140,5
040-063	100	70	112	72	72	63	107	50	40	36,5	71,5	156,5
040-075	100	70	120	86	89	75	119	50	40	36,5	71,5	167,5
040-090	100	70	140	103	103	90	135	50	40	36,5	71,5	184,5
050-075	120	80	120	86	89	75	119	60	50	43,5	84	195,5
050-090	120	80	140	103	103	90	135	60	50	43,5	84	205
050-110	120	80	155	127,5	127,5	110	167,5	60	50	43,5	84	226
063-075	144	109	120	86	89	75	119	72	63	53	107	195,5
063-090	144	109	140	103	103	90	135	72	63	53	107	214
063-110	144	109	155	127,5	127,5	110	167,5	72	63	53	107	237
063-130	144	109	170	147,5	147,5	130	187,5	72	63	53	107	245
063-150	144	109	200	170	170	150	230	72	63	53	107	275

3.1.8 NRV/NRV-P+NMRV/NMRV-P

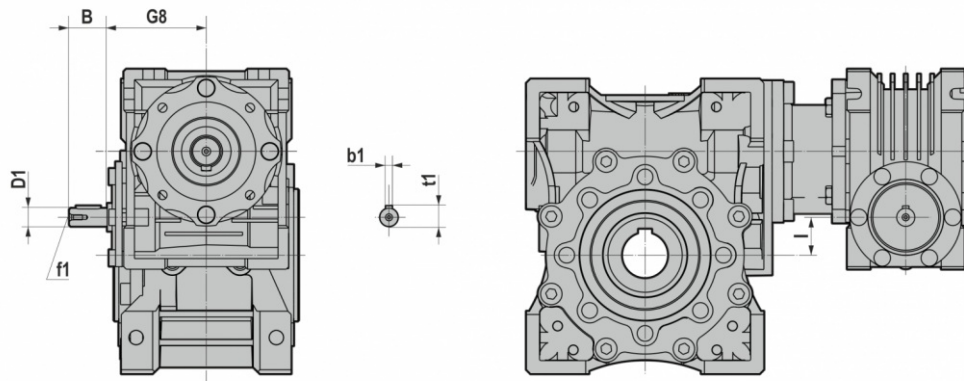

	B	D1	G8	l8	b1	fl	t1
030-040	20	9	51	10	3	-	10,2
030-050	20	9	51	20	3	-	10,2
030-063	20	9	51	33	3	-	10,2
040-050	23	11	60	10	4	-	12,5
040-063	23	11	60	23	4	-	12,5
040-075	23	11	60	35	4	-	12,5
040-090	23	11	60	50	4	-	12,5
050-090	30	14	74	40	5	M6	16
050-110	30	14	74	60	5	M6	16
063-110	40	19	90	47	6	M6	21,5
063-130	40	19	90	67	6	M6	21,5
063-150	40	19	90	87	6	M6	21,5

The values reported in the tables are referred to the weight of the gearbox with lubricant included.
Weight without motor.

NMRV - NMRV-P (- kg)										
025	030	040	050	063	075	090	110	130	150	
0,7	1,2	2,3	3,5	6,2	9	13	21	43,5	84	

NRV - NRV-P (- kg)									
030	040	050	063	075	090	110	130	150	
1	2	3,3	5,8	8,8	13	21	43,5	77	

	HA31+NMRV040 (- kg)	HA31+NMRV050 (- kg)
063	4,2	5,4
071	4,3	5,5
080	4,5	5,7

056/063/071/080		063/071/080/090	
NMRV-P063/HW030 (- kg)	NMRV-P075/HW030 (- kg)	NMRV-P090/HW040 (- kg)	NMRV-P110/HW040 (- kg)
7,1	10	14,6	24,4

NMRV-P090/HW040 (- kg)	NMRV-P110/HW040 (- kg)
14,6	38,4

NMRV+NMRV - NMRV+NMRV-P - NMRV-P+NMRV - NMRV-P+NMRV-P (- kg)													
025-030	025-040	030-040	030-050	030-063	040-050	040-063	040-075	040-090	050-090	050-110	063-110	063-130	063-150
1,9	3	3,5	4,7	7,4	5,8	8,5	11,3	15,3	16,5	38,5	41,2	54,2	90,2

NRV+NMRV - NRV+NMRV-P - NRV-P+NMRV - NRV-P+NMRV-P (- kg)											
030-040	030-050	030-063	040-050	040-063	040-075	040-090	050-090	050-110	063-110	063-130	063-150
3,5	4,7	7,4	5,8	8,5	11,3	15,3	16,5	38,5	41,2	54,2	90,2

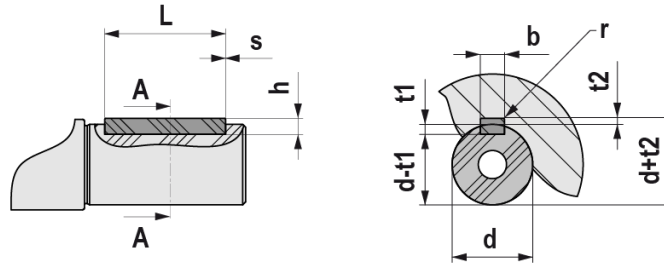

UNI 6604 - DIN 6885														
d		b x h		Tol. b/h	L		s min / max		b	t1	t2	Tol. t1/t2	r max	
	6	8	2	x	2	h9 / h9	6	20	0,16 0,25	2	1,2	1	0,1 0	0,08 0,16
>	8	10	3	x	3		6	36		3	1,8	1,4		
>	10	12	4	x	4		8	45		4	2,5	1,8		
>	12	17	5	x	5		10	56	5	3	2,3	0,25 0,4	0,16 0,25	
>	17	22	6	x	6		14	70	6	3	2,8			
>	22	30	8	x	7		18	90	8	4	3,3			
>	30	38	10	x	8	22	110	10	5	3,3	0,2 0	0,25 0,4		
>	38	44	12	x	8	28	140	12	5	3,3				
>	44	50	14	x	9	36	160	14	5,5	3,8				
>	50	58	16	x	10	45	180	16	6	4,3				
>	58	65	18	x	11	50	200	18	7	4,4				
>	65	75	20	x	12	56	110	20	7,5	4,9			0,6 0,8	0,4 0,6
>	75	85	22	x	14	63	140	22	9	5,4				
>	85	95	25	x	14	70	160	25	9	5,4				
>	95	110	28	x	16	80	180	28	10	6,4				
>	110	130	32	x	18	90	200	32	11	7,4				
>	130	150	36	x	20	100	160	36	12	8,4	1 1,2	0,7 1		
>	150	170	40	x	22	110	180	40	13	9,4				
>	170	200	45	x	25	125	200	45	14	10,4				

3.4.1 Electric motors

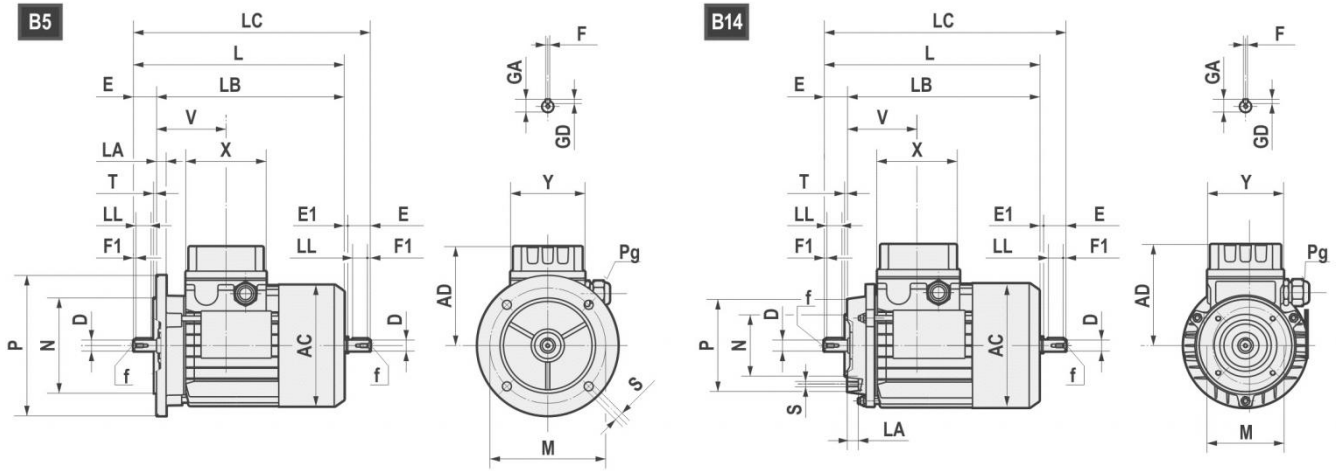

	AC	AD	L	LB	LC	X	Y	V	D	E	E1	f	F1	GA	F	GD
63	121	104	211	188	235,5	80	74	69	11 j6	23	1,5	M4x10	2,5	12,5	4	4
71	139	112	238,5	208,5	271	80	74	74,5	14 j6	30	2,5	M5x12.5	3	16	5	5
80	158	122	272,5 *(296)	232,5 *(256)	314 *(337)	80	74	78	19 j6	40	1,5	M6x16	5	21,5	6	6
90S	173	146	298 *(331)	248 *(281)	349,5 *(381)	98	98	89,5	24 j6	50	1,5	M8x19	5	27	8	7
90L	173	146	323 *(356)	273 *(306)	374,5 *(408)	98	98	89,5	24 j6	50	1,5	M8x19	5	27	8	7
100	191	155	368	308	431,5	98	98	97,5	28 j6	60	3,5	M10x22	7,5	31	8	7
112	211	170	382,5 *(408)	322,5 *(348)	447 *(472)	98	98	100	28 j6	60	3,5	M10x22	7,5	31	8	7
132S	249	195	452	372	536,5	118	118	115,5	38 k6	80	4	M12x28	10	41	10	8
132L	249	195	490	410	574,5	118	118	115,5	38 k6	80	4	M12x28	10	41	10	8
160S	249	195	520	410	/	118	118	115,5	42k6	100	/	M16x36	10	45	12	8

*TP80B4, TP90S4, TP90L4, TP90S6, TP112M4, TP112M6

B5	M	N	P	LA	S	T
63	115	95	140	10	9	3
71	130	110	160	10	9,5	3,5
80	165	130	200	12	11	3,5
90	165	130	200	12	11	3,5
100	215	180	250	15	14	4
112	215	180	250	14,5	14	4
132	265	230	300	20	14	3,5
160	300	250	350	13	18,5	3,5

B14	M	N	P	LA	S	T
63	75	60	90	10	M5	2,5
71	85	70	105	10,5	M6	2,5
80	100	80	120	10,5	M6	3
90	115	95	140	11,5	M8	3
100	130	110	160	15	M8	3,5
112	130	110	160	11,5	M8	3,5
132	165	130	200	20,5	M10	3,5
160	215	180	250	-	M12	4

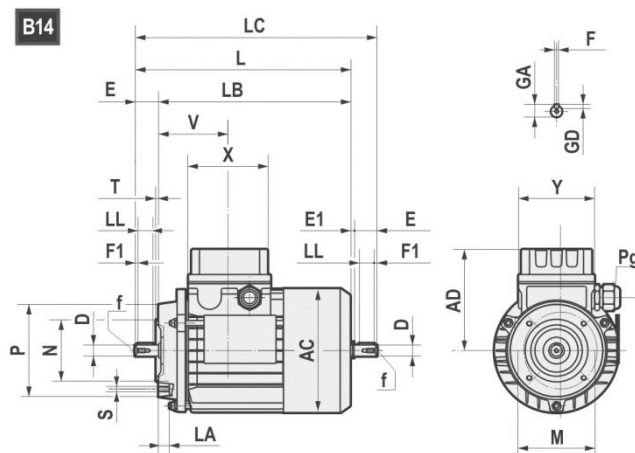
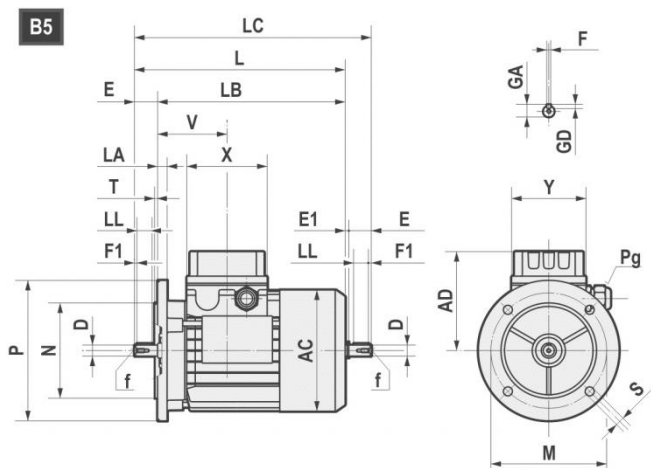

		AC	AD	L	LB	X	D	E	f	GA	F	GD	LL	Pg	
160M	4-6	314	251	600	490	158	42	110	M16	45	12	8	90	2-M40x1,5	1-M16x1,5
160L	4-6	314	251	645	535	158	42	110	M16	45	12	8	90	2-M40x1,5	1-M16x1,5
180M	4	355	267	680	570	158	48	110	M16	51,5	14	9	100	2-M40x1,5	1-M16x1,5
180L	6	355	267	720	610	158	48	110	M16	51,5	14	9	100	2-M40x1,5	1-M16x1,5
200L	4-6	397	300	785	675	187	55	110	M20	59	16	10	100	2-M50x1,5	1-M16x1,5
225S	4	446	325	820	680	187	60	140	M20	64	18	11	125	2-M50x1,5	1-M16x1,5
225M	4-6	446	325	845	705	187	60	140	M20	64	18	11	125	2-M50x1,5	1-M16x1,5
250M	4-6	485	360	910	770	238	60	140	M20	64	18	11	125	2-M63x1,5	1-M16x1,5
250M	4-6	485	360	910	770	238	65	140	M20	69	18	11	125	2-M63x1,5	1-M16x1,5
280S	4-6	547	390	970	830	238	65	140	M20	69	18	11	125	2-M63x1,5	1-M16x1,5
280S	4-6	547	390	970	830	238	75	140	M20	79,5	20	12	125	2-M63x1,5	1-M16x1,5
280M	4-6	547	390	1025	885	238	65	140	M20	69	18	11	125	2-M63x1,5	1-M16x1,5
280M	4-6	547	390	1025	885	238	75	140	M20	79,5	20	12	125	2-M63x1,5	1-M16x1,5

B5	M	N	P	LA	S	T
160	300	250	350	13	19	5
180	300	250	350	15	19	5
200	350	300	400	17	19	5
225	400	350	450	20	19	5
250	500	450	550	22	19	5
280	500	450	550	22	19	5

3.4.2 Standard high efficiency (TS), high (TH) and premium (TP) motors

Motovario, three-phase, single polarity motors are available in three different versions (IE1-IE2-IE3) in compliance with standard 60034-30-1. The efficiency value is calculated according to the method set forth in standard IEC 60034-2-1.

1. IE1: Standard efficiency TS series for rated power less than 0.12 kW;
2. IE2: High efficiency TH series for rated power greater than or equal to 0.12 kW and less than 0.75 kW;
3. IE3: Premium efficiency TP series (*) for nominal power greater than or equal to 0.75 kW.

Table of Motovario commercial availability

NOMINAL POWER [kW]	EFFICIENCY LEVEL		
	IE1	IE2	IE3
$P_n < 0,12$	TS-TBS	-	-
$0,12 \leq P_n < 0,75$	-	TH-TBH	-
$P_n \geq 0,75$	-	-	TP-TBP

(*) Motor TP100LA4 2,2 kW and all TP 6 poles motors are available at 60Hz only upon request. As a consequence, these motors are in IE3 efficiency level at 50 Hz and IE2 at 60 Hz in case of bifrequency electrical design (standard 230/400-265/460V 50-60Hz and optional 200/346-220/380V 50-60Hz, 290/500-330/575V 50-60Hz and 400/690-460/800V 50-60Hz, see chapter on input voltage and frequency, see motors catalog).

3.4.3 Nominal power - [kW]

	63A	63B	63C	71A	71B	71C	80A			80B		
P.	TS	TS	TS	TS	TS	TS	TS	TH	TP	TS	TH	TP
4	0,12	0,18	0,22	0,25	0,37	0,55	0,55	-	-	-	0,75	0,75
6	0,09	0,12	0,15	0,18	0,25	0,37	0,37	-	-	0,55	-	-

	90S		90L		100LR	100L	100LA		112MR	112MS	112MA	112M
P.	TH	TP	TH	TP	TP	TP	TH	TP	TP	TP	TH	TP
4	1,1	1,1	1,5	1,5	-	-	2,2	2,2	2,2	3	4	4
6	-	0,75	0,75	-	1,1	1,5	1,1	-	-	-	2,2	2,2

	112MR	112MS	132S	132SA	132MS	132SB	132M	132MA		132MB	
P.	TP	TP	TP	TH	TP	TH	TP	TH	TP	TH	TP
4	2,2	3	-	5,5	5,5	-	7,5	7,5	-	9,2	-
6	-	-	3	3	-	-	-	4	4	5,5	5,5

	160M	160MA	160MB	160L	160LA	180M	180L
P.	TP	TP	TP	TP	TP	TP	TP
4	-	11	-	-	15	18,5	22
6	7,5	-	-	11	-	-	15

	200L	200LA	200LB	225S	225M	250M	280S	280M
P.	TP	TP	TP	TP	TP	TP	TP	TP
4	30	-	-	37	45	55	75	90
6	-	18,5	22	-	-	-	-	-

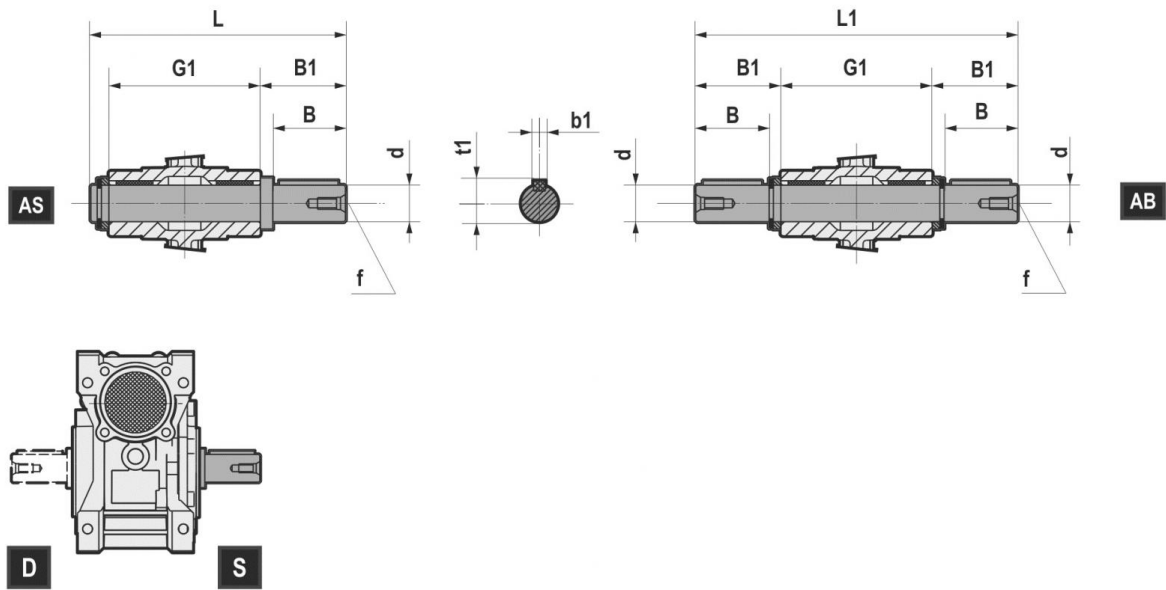

		d	B	B1	G1	L	L1	f	b1	t1
NMRV	025	11g6 (9)	23 (25)	25,5 (30)	50	81 (85,5)	101 (110)	-	4 (3)	12,5 (10,2)
NMRV	030	14 h6	30	32,5	63	102	128	M6	5	16
NMRV	040	18 h6	40	43	78	128	164	M6	6	20,5
NMRV	050	25 h6	50	53,5	92	153	199	M10	8	28
NMRV-P	063	25 h6	50	53,5	112	173	219	M10	8	28
NMRV-P	075	28 h6	60	63,5	120	192	247	M10	8	31
NMRV-P	090	35 h6	80	84,5	140	234	309	M12	10	38
NMRV-P	110	42 h6	80	84,5	155	249	324	M16	12	45
NMRV	130	45 h6	80	85	170	265	340	M16	14	48,5
NMRV	150	50 h6	82	87	200	297	374	M16	14	53,5

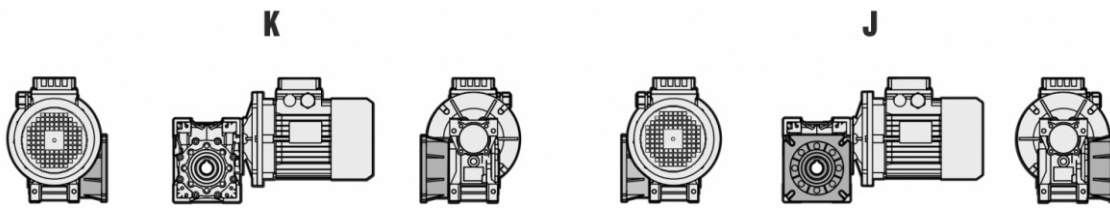

Unless specified otherwise, the reduction unit is supplied with the flange in pos. J referred to position B3.

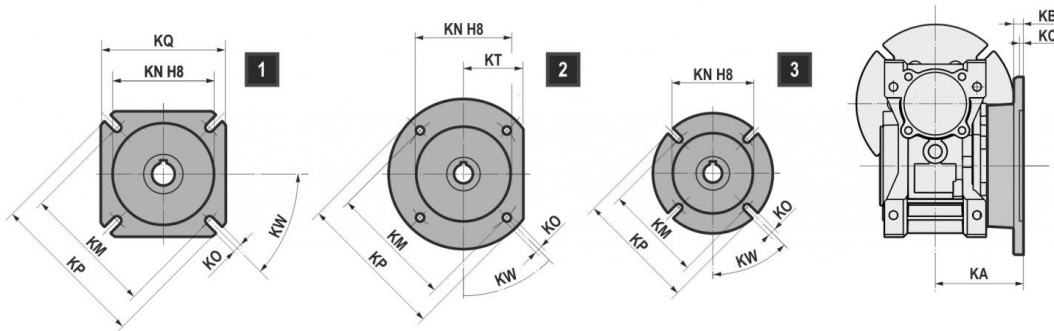

	NMRV	NMRV	NMRV	NMRV-P	NMRV-P	NMRV-P	NMRV-P	NMRV	NMRV
	030	040	050	063	075	090	110	130	150
FA	1	1	1	1	1	1	1	1	1
FB	-	1	1	1	3	2	1	-	-
FC	-	2	2	2	-	3	-	-	-
FD	-	2	2	2	-	1	-	-	-
FE	-	-	-	3	-	-	-	-	-

		FA									FB									
		KA	KB	KC	KN	KM	KO	KP	KQ	KW	KA	KB	KC	KN	KM	KO	KP	KQ	KT	KW
NMRV	030	54,5	6	4	50	68	6.5 (n ^o 4)	80	70	45°	-	-	-	-	-	-	-	-	-	-
NMRV	040	67	7	4	60	80 min	9 (n ^o 4)	110	95	45°	97	7	4	60	80 min	9 (n ^o 4)	110	95	-	45°
NMRV	050	90	9	5	70	90 min	11 (n ^o 4)	125	110	45°	120	9	5	70	90 min	11 (n ^o 4)	125	110	-	45°
NMRV-P	063	82	10	6	115	150	11 (n ^o 4)	180	142	45°	112	10	6	115	150	11 (n ^o 4)	180	142	-	45°
NMRV-P	075	111	13	6	130	165	14 (n ^o 4)	200	170	45°	90	13	6	110	130	11 (n ^o 4)	160	-	-	45°
NMRV-P	090	111	13	6	152	175	14 (n ^o 4)	210	200	45°	122	18	6	180	215	14 (n ^o 4)	250	-	105	45°
NMRV-P	110	131	15	6	170	230	14 (n ^o 8)	280	260	45°	180	15	6	170	230	14 (n ^o 8)	280	260	-	45°
NMRV	130	140	15	6	180	255	16 (n ^o 8)	320	290	22.5°	-	-	-	-	-	-	-	-	-	-
NMRV	150	155	15	6	180	255	16 (n ^o 8)	320	290	22.5°	-	-	-	-	-	-	-	-	-	-

		FC									FD									
		KA	KB	KC	KN	KM	KO	KP	KT	KW	KA	KB	KC	KN	KM	KO	KP	KQ	KT	KW
NMRV	040	80	9	5	95	115	9.5 (n ^o 4)	140	56	45°	58	12	5	80	100	9 (n ^o 4)	120	-	50	45°
NMRV	050	89	10	5	110	130	9.5 (n ^o 4)	160	66	45°	72	14,5	5	95	115	11 (n ^o 4)	140	-	60	45°
NMRV-P	063	98	10	5	130	165	11 (n ^o 4)	200	80	45°	107	10	5	130	165	11 (n ^o 4)	200	-	-	45°
NMRV-P	090	110	17	6	130	165	11 (n ^o 4)	200	-	45°	151	13	6	152	175	14 (n ^o 4)	210	200	-	45°

		FE							
		KA	KB	KC	KN	KM	KO	KP	KW
NMRV-P	063	80,5	16,5	5	110	130	11 (n ^o 4)	160	45°

4.3.1 Torque arm: Mounting position

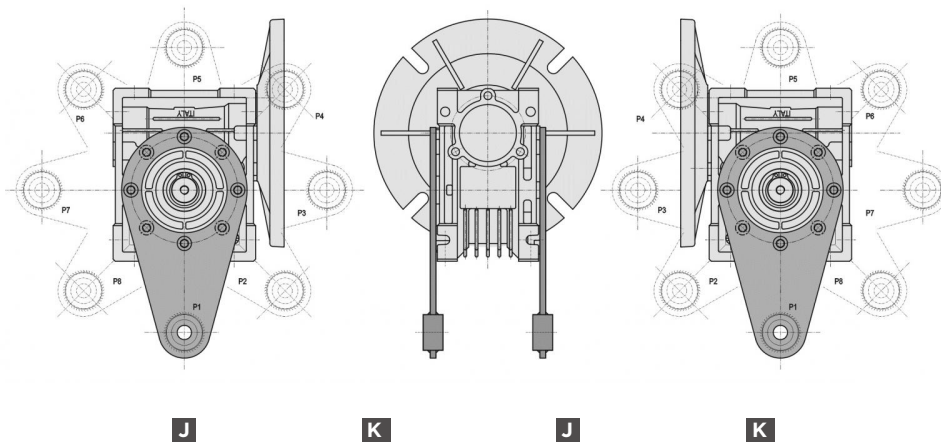

NMRV NMRV-P NMRL	P1		P2		P3		P4		P5		P6		P7		P8	
	J	K	J	K	J	K	J	K	J	K	J	K	J	K	J	K
025			/	/	NO	NO	/	/			/	/			/	/
030			NO	NO	NO	NO	NO	NO								
040	NO NMRL		NO	NO	NO	NO	NO	NO	NO NMRL		NO NMRL		NO NMRL		NO NMRL	
050			NO	NO	NO	NO	NO	NO			NO	NO				
063					NO	NO	NO	NO								
075			NO	NO	NO	NO	NO	NO								
090					NO	NO	NO	NO								
110					NO	NO	NO	NO								
130					NO	NO	NO	NO								
150			NO	NO	NO	NO	NO	NO	NO	NO	NO	NO			NO	NO

(/) Not available

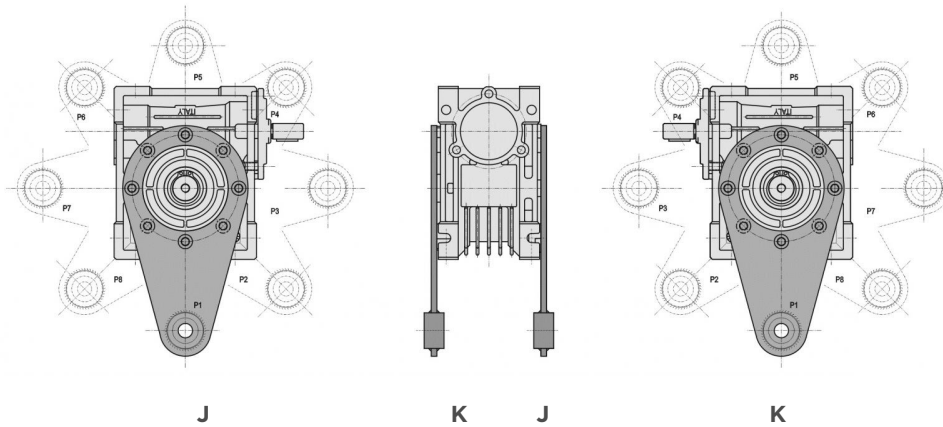

NRV NRV-P NRL	P1		P2		P3		P4		P5		P6		P7		P8		
	J	K	J	K	J	K	J	K	J	K	J	K	J	K	J	K	
030			NO	NO			NO	NO									
040	NO NRL		NO NRL	NO	NO NRL	NO	NO	NO	NO NRL		NO NRL		NO NRL		NO NRL		
050			NO	NO			NO	NO			NO	NO					
063							NO	NO									
075							NO	NO									
090							NO	NO									
110							NO	NO									
130							NO	NO									
150			NO	NO			NO	NO	NO	NO	NO	NO				NO	NO

(/) Not available

For information on torque arm mounting positions on combined worm gear reducers and worm gear reducers with pre-stage units, please contact our Technical Service.

4.3.2 Torque arm: Dimensions

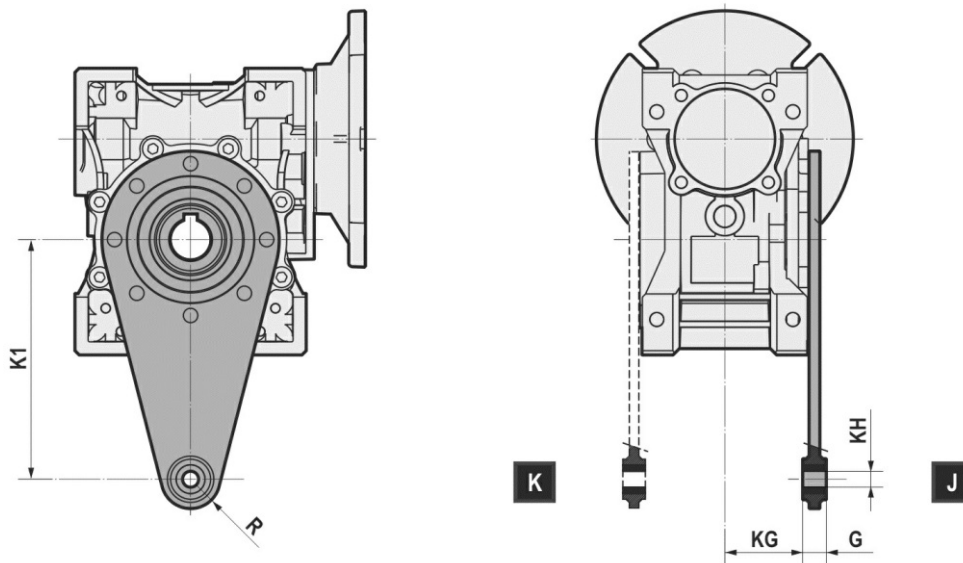

NMRV NMRV-P	025	030	040	050	063	075	090	110	130	150
K1	70	85	100	100	150	200	200	250	250	250
G	14	14	14	14	14	25	25	30	30	30
KG	17,5	24	31,5	38,5	49	47,5	57,5	62	69	84
KH	8 +0,1/+0,05	8 +0,1/+0,05	10 +0,3/0	10 +0,3/0	10 +0,3/0	20 +0,3/0	20 +0,3/0	25 +0,3/0	25 +0,3/0	25 +0,3/0
R	15	15	18	18	18	30	30	35	35	35

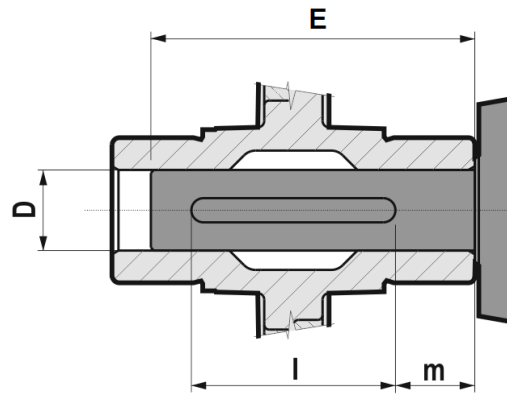

	D H8/h6	E*	l*	m*
025	11 (H8/g6)	45	30	7,5
030	14	55	40	7,5
040	18	70	50	10
	19			
050	24	80	55	12,5
	25			
063	25	100	70	15
	28			
075	28	105	75	15
	30			
	32			
090	35	120	80	20
	38			
	40			
105	42	135	95	20
110	42	135	95	20
130	45	145	100	22,5
150	50	175	130	22,5

(*) Suggested values.

0,09 kW

n2 [rpm]	M2 [Nm]	fs	i	Gear reducer	Motor		Fr2 [N]
					Size	Pole	
125,0	6	3,2	10,00	NMRV030	56B	4	752
115,0	6	2,9	7,50	NMRV030	63A	6	792
86,0	8	2,2	10,00	NMRV030	63A	6	871
83,0	8	2,2	15,00	NMRV030	56B	4	861
63,0	10	1,7	20,00	NMRV030	56B	4	948
57,0	11	1,6	15,00	NMRV030	63A	6	997
50,0	12	1,8	25,00	NMRV030	56B	4	1021
43,0	14	1,2	20,00	NMRV030	63A	6	1098
43,0	15	2,7	20,00	NMRV040	63A	6	2113
42,0	14	1,5	30,00	NMRV030	56B	4	1085
34,0	16	1,3	25,00	NMRV030	63A	6	1183
34,0	18	2,0	25,00	NMRV040	63A	6	2276
31,0	17	1,1	40,00	NMRV030	56B	4	1194
29,0	19	1,1	30,00	NMRV030	63A	6	1257
29,0	20	2,3	30,00	NMRV040	63A	6	2419
25,0	22	1,8	50,00	NMRV040	56B	4	2475
22,0	25	1,7	40,00	NMRV040	63A	6	2662
22,0	26	3,0	40,00	NMRV050	63A	6	3654
21,0	24	1,5	60,00	NMRV040	56B	4	2630
17,0	29	1,4	50,00	NMRV040	63A	6	2868
17,0	30	2,4	50,00	NMRV050	63A	6	3936
16,0	29	1,1	80,00	NMRV040	56B	4	2895
14,0	33	1,1	60,00	NMRV040	63A	6	3047
14,0	34	2,0	60,00	NMRV050	63A	6	4183
12,5	40	3,7	100,00	NMRV-P030/063	56B	4	4967
12,5	39	1,8	100,00	NMRV030/040	56B	4	2769
12,5	40	3,4	100,00	NMRV030/050	56B	4	3800
11,0	40	1,6	80,00	NMRV050	63A	6	4604
9,0	45	1,2	100,00	NMRV050	63A	6	4840
8,3	56	3,7	150,00	NMRV-P030/063	56B	4	5686
8,3	55	1,3	150,00	NMRV030/040	56B	4	3169
8,3	55	2,4	150,00	NMRV030/050	56B	4	4350
8,0	73	3,2	109,09	HW030+NMRV-P063	63A	6	6270
7,0	58	2,8	176,67	HW030+NMRV-P063	56B	4	6270
7,0	83	3,1	118,13	HW030+NMRV-P063	63A	6	6270
6,2	70	3,5	200,00	NMRV-P030/063	56B	4	6259
6,2	69	1,7	200,00	NMRV030/050	56B	4	4788
6,0	84	2,8	142,50	HW030+NMRV-P063	63A	6	6270
6,0	88	2,5	136,36	HW030+NMRV-P063	63A	6	6270
6,0	79	3,0	218,18	HW030+NMRV-P063	56B	4	6270
6,0	85	2,8	196,88	HW030+NMRV-P063	56B	4	6270
5,0	96	2,6	163,64	HW030+NMRV-P063	63A	6	6270

0,09 kW

n2 [rpm]	M2 [Nm]	fs	i	Gear reducer	Size	Motor Pole	Fr2 [N]
5,0	105	2,5	157,50	HW030+NMRV-P063	63A	6	6270
5,0	93	3,0	236,25	HW030+NMRV-P063	56B	4	6270
5,0	84	2,7	250,00	NMRV-P030/063	56B	4	6270
5,0	82	1,3	250,00	NMRV030/050	56B	4	4840
4,9	86	2,0	176,67	HW030+NMRV-P063	63A	6	6270
4,9	91	3,1	176,67	HW030+NMRV-P075	63A	6	7380
4,6	93	2,4	272,73	HW030+NMRV-P063	56B	4	6270
4,4	125	1,9	196,88	HW030+NMRV-P063	63A	6	6270
4,4	129	3,0	196,88	HW030+NMRV-P075	63A	6	7380
4,2	87	2,9	300,00	NMRV-P030/063	56B	4	6270
4,2	91	1,6	300,00	NMRV030/050	56B	4	4840
4,0	113	2,3	315,00	HW030+NMRV-P063	56B	4	6270
4,0	120	3,5	315,00	HW030+NMRV-P075	56B	4	7380
3,9	117	2,0	218,18	HW030+NMRV-P063	63A	6	6270
3,9	124	3,2	218,18	HW030+NMRV-P075	63A	6	7380
3,6	136	2,0	236,25	HW030+NMRV-P063	63A	6	6270
3,6	143	3,1	236,25	HW030+NMRV-P075	63A	6	7380
3,2	136	1,6	272,73	HW030+NMRV-P063	63A	6	6270
3,2	132	1,8	393,75	HW030+NMRV-P063	56B	4	6270
3,2	141	2,6	272,73	HW030+NMRV-P075	63A	6	7380
3,2	135	2,8	393,75	HW030+NMRV-P075	56B	4	7380
3,1	113	2,2	400,00	NMRV-P030/063	56B	4	6270
3,1	109	1,1	400,00	NMRV030/050	56B	4	4840
2,9	153	1,7	433,33	HW030+NMRV-P063	56B	4	6270
2,8	168	3,3	304,55	HW040+NMRV-P090	63A	6	8180
2,7	166	1,6	315,00	HW030+NMRV-P063	63A	6	6270
2,7	176	2,4	315,00	HW030+NMRV-P075	63A	6	7380
2,6	144	1,5	472,50	HW030+NMRV-P063	56B	4	6270
2,6	153	2,4	472,50	HW030+NMRV-P075	56B	4	7380
2,6	170	3,0	330,00	HW040+NMRV-P090	63A	6	8180
2,5	131	1,8	500,00	NMRV-P030/063	56B	4	6270
2,3	179	1,4	541,67	HW030+NMRV-P063	56B	4	6270
2,3	185	1,7	541,67	HW030+NMRV-P075	56B	4	7380
2,2	193	1,2	393,75	HW030+NMRV-P063	63A	6	6270
2,2	200	1,9	393,75	HW030+NMRV-P075	63A	6	7380
2,2	209	2,9	383,33	HW040+NMRV-P090	63A	6	8180
2,1	164	1,6	600,00	NMRV-P030/063	56B	4	6270
2,0	225	1,2	433,33	HW030+NMRV-P063	63A	6	6270
2,0	238	2,6	437,50	HW040+NMRV-P090	63A	6	8180
2,0	223	3,4	440,00	HW040+NMRV-P110	63A	6	10320
1,9	196	1,1	650,00	HW030+NMRV-P063	56B	4	6270
1,9	209	1,7	650,00	HW030+NMRV-P075	56B	4	7380

0,09 kW

n2 [rpm]	M2 [Nm]	fs	i	Gear reducer	Size	Motor Pole	Fr2 [N]
1,9	233	2,3	460,00	HW040+NMRV-P090	63A	6	8180
1,8	212	1,0	472,50	HW030+NMRV-P063	63A	6	6270
1,8	226	1,6	472,50	HW030+NMRV-P075	63A	6	7380
1,7	192	1,4	750,00	NMRV-P030/063	56B	4	6270
1,6	199	1,1	787,50	HW030+NMRV-P075	56B	4	7380
1,6	271	1,2	541,67	HW030+NMRV-P075	63A	6	7380
1,6	265	2,1	525,00	HW040+NMRV-P090	63A	6	8180
1,6	285	3,2	525,00	HW040+NMRV-P110	63A	6	10320
1,4	246	1,1	866,67	HW030+NMRV-P075	56B	4	7380
1,4	283	1,5	613,33	HW040+NMRV-P090	63A	6	8180
1,4	307	2,6	613,33	HW040+NMRV-P110	63A	6	10320
1,4	220	1,2	900,00	NMRV-P030/063	56B	4	6270
1,3	307	1,2	650,00	HW030+NMRV-P075	63A	6	7380
1,2	322	1,3	700,00	HW040+NMRV-P090	63A	6	8180
1,2	349	2,3	700,00	HW040+NMRV-P110	63A	6	10320
1,1	315	1,1	766,67	HW040+NMRV-P090	63A	6	8180
1,1	344	1,9	766,67	HW040+NMRV-P110	63A	6	10320
1,0	267	1,0	1200,00	NMRV-P030/063	56B	4	6270
1,0	391	1,6	875,00	HW040+NMRV-P110	63A	6	10320
0,8	367	1,2	1500,00	NMRV-P040/075	56B	4	7380
0,8	385	1,8	1500,00	NMRV-P040/090	56B	4	8180
0,7	412	1,1	1800,00	NMRV-P040/075	56B	4	7380
0,7	432	1,6	1800,00	NMRV-P040/090	56B	4	8180
0,5	533	1,1	2400,00	NMRV-P040/090	56B	4	8180

0,12 kW

n2 [rpm]	M2 [Nm]	fs	i	Gear reducer	Size	Motor Pole	Fr2 [N]
264,0	4	3,3	10,00	NMRV030	56B	2	597
180,3	5	3,3	7,50	NMRV030	63A	4	683
176,3	5	2,3	15,00	NMRV030	56B	2	683
174,0	6	3,2	5,00	NMRV030	63B	6	692
135,0	7	2,5	10,00	NMRV030	63A	4	752
132,5	7	1,8	20,00	NMRV030	56B	2	752
116,3	8	2,2	7,50	NMRV030	63B	6	792
105,6	8	1,8	25,00	NMRV030	56B	2	810
89,7	10	1,8	15,00	NMRV030	63A	4	861
87,7	9	1,6	30,00	NMRV030	56B	2	861
87,0	11	1,7	10,00	NMRV030	63B	6	871
67,5	13	1,3	20,00	NMRV030	63A	4	948
67,5	14	3,0	20,00	NMRV040	63A	4	1824
65,8	12	1,2	40,00	NMRV030	56B	2	948

0,12 kW

n2 [rpm]	M2 [Nm]	fs	i	Gear reducer	Size	Motor Pole	Fr2 [N]
57,7	15	1,2	15,00	NMRV030	63B	6	997
57,7	16	2,7	15,00	NMRV040	63B	6	1920
54,4	15	1,4	25,00	NMRV030	63A	4	1021
54,4	16	2,3	25,00	NMRV040	63A	4	1964
52,8	15	1,9	50,00	NMRV040	56B	2	1964
45,3	17	1,2	30,00	NMRV030	63A	4	1085
45,3	18	2,5	30,00	NMRV040	63A	4	2087
43,8	17	1,6	60,00	NMRV040	56B	2	2087
43,5	20	2,0	20,00	NMRV040	63B	6	2113
34,4	24	1,5	25,00	NMRV040	63B	6	2276
34,3	23	1,9	40,00	NMRV040	63A	4	2298
34,3	23	3,4	40,00	NMRV050	63A	4	3153
32,9	21	1,2	80,00	NMRV040	56B	2	2298
29,3	27	1,7	30,00	NMRV040	63B	6	2419
27,2	27	1,5	50,00	NMRV040	63A	4	2475
27,2	27	2,7	50,00	NMRV050	63A	4	3397
22,3	34	1,3	40,00	NMRV040	63B	6	2662
22,3	34	2,3	40,00	NMRV050	63B	6	3654
22,2	30	1,2	60,00	NMRV040	63A	4	2630
22,2	31	2,2	60,00	NMRV050	63A	4	3610
17,2	39	1,0	50,00	NMRV040	63B	6	2868
17,2	40	1,8	50,00	NMRV050	63B	6	3936
17,1	37	1,7	80,00	NMRV050	63A	4	3973
14,2	44	1,5	60,00	NMRV050	63B	6	4183
13,5	54	2,8	100,00	NMRV-P030/O63	63A	4	4967
13,5	52	1,4	100,00	NMRV030/O40	63A	4	2769
13,5	54	2,6	100,00	NMRV030/O50	63A	4	3800
13,5	55	2,5	100,00	NMRV040/O50	63A	4	3800
13,1	43	1,2	100,00	NMRV050	63A	4	4280
12,1	64	3,7	109,09	HW030+NMRV-P063	63A	4	5844
11,1	70	2,9	77,33	HW030+NMRV-P063	63B	6	6041
11,1	77	3,0	81,82	HW030+NMRV-P063	63B	6	6155
11,1	52	1,2	80,00	NMRV050	63B	6	4604
11,1	71	3,6	118,13	HW030+NMRV-P063	63A	4	6001
10,1	71	2,8	88,33	HW030+NMRV-P063	63B	6	6270
10,1	76	2,8	136,36	HW030+NMRV-P063	63A	4	6270
9,1	85	2,6	95,00	HW030+NMRV-P063	63B	6	6270
9,1	73	3,2	142,50	HW030+NMRV-P063	63A	4	6270
9,1	90	2,9	157,50	HW030+NMRV-P063	63A	4	6270
9,0	74	2,8	150,00	NMRV-P030/O63	63A	4	5686
9,0	76	3,4	150,00	NMRV-P040/O63	63A	4	5686
9,0	73	1,8	150,00	NMRV030/O50	63A	4	4350

0,12 kW

n2 [rpm]	M2 [Nm]	fs	i	Gear reducer	Size	Motor Pole	Fr2 [N]
9,0	75	1,8	150,00	NMRV040/050	63A	4	4350
8,1	97	2,4	109,09	HW030+NMRV-P063	63B	6	6270
8,1	77	2,1	176,67	HW030+NMRV-P063	63A	4	6270
8,1	83	2,9	163,64	HW030+NMRV-P063	63A	4	6270
8,1	82	3,4	176,67	HW030+NMRV-P075	63A	4	7380
7,1	110	2,4	118,13	HW030+NMRV-P063	63B	6	6270
7,1	108	2,2	196,88	HW030+NMRV-P063	63A	4	6270
7,1	111	3,5	196,88	HW030+NMRV-P075	63A	4	7380
6,8	94	2,7	200,00	NMRV-P030/063	63A	4	6259
6,8	96	2,6	200,00	NMRV-P040/063	63A	4	6259
6,8	93	1,3	200,00	NMRV030/050	63A	4	4788
6,8	95	1,2	200,00	NMRV040/050	63A	4	4788
6,1	111	2,1	142,50	HW030+NMRV-P063	63B	6	6270
6,1	116	1,8	136,36	HW030+NMRV-P063	63B	6	6270
6,1	118	2,9	154,67	HW030+NMRV-P075	63B	6	7380
6,1	117	3,2	142,50	HW030+NMRV-P075	63B	6	7380
6,1	120	2,9	136,36	HW030+NMRV-P075	63B	6	7380
6,0	102	2,3	218,18	HW030+NMRV-P063	63A	4	6270
6,0	118	2,3	236,25	HW030+NMRV-P063	63A	4	6270
6,0	107	3,6	218,18	HW030+NMRV-P075	63A	4	7380
6,0	124	3,6	236,25	HW030+NMRV-P075	63A	4	7380
5,4	113	2,0	250,00	NMRV-P030/063	63A	4	6270
5,4	116	2,0	250,00	NMRV-P040/063	63A	4	6270
5,4	119	3,2	250,00	NMRV-P040/075	63A	4	7380
5,1	127	1,9	163,64	HW030+NMRV-P063	63B	6	6270
5,1	138	1,9	157,50	HW030+NMRV-P063	63B	6	6270
5,1	132	3,0	163,64	HW030+NMRV-P075	63B	6	7380
5,0	113	1,5	176,67	HW030+NMRV-P063	63B	6	6270
5,0	120	2,3	176,67	HW030+NMRV-P075	63B	6	7380
4,9	119	1,8	272,73	HW030+NMRV-P063	63A	4	6270
4,9	124	2,9	272,73	HW030+NMRV-P075	63A	4	7380
4,7	132	3,1	186,32	HW040+NMRV-P090	63B	6	8180
4,5	116	2,2	300,00	NMRV-P030/063	63A	4	6270
4,5	126	2,1	300,00	NMRV-P040/063	63A	4	6270
4,5	133	3,3	300,00	NMRV-P040/075	63A	4	7380
4,5	121	1,2	300,00	NMRV030/050	63A	4	4840
4,5	124	1,2	300,00	NMRV040/050	63A	4	4840
4,5	165	1,4	196,88	HW030+NMRV-P063	63B	6	6270
4,5	170	2,3	196,88	HW030+NMRV-P075	63B	6	7380
4,4	147	3,7	304,55	HW040+NMRV-P090	63A	4	8180
4,3	144	1,8	315,00	HW030+NMRV-P063	63A	4	6270
4,3	152	2,8	315,00	HW030+NMRV-P075	63A	4	7380

0,12 kW

n2 [rpm]	M2 [Nm]	fs	i	Gear reducer	Size	Motor Pole	Fr2 [N]
4,1	150	3,3	330,00	HW040+NMRV-P090	63A	4	8180
3,9	154	1,5	218,18	HW030+NMRV-P063	63B	6	6270
3,9	163	2,4	218,18	HW030+NMRV-P075	63B	6	7380
3,6	180	1,5	236,25	HW030+NMRV-P063	63B	6	6270
3,6	189	2,4	236,25	HW030+NMRV-P075	63B	6	7380
3,5	182	3,3	383,33	HW040+NMRV-P090	63A	4	8180
3,4	175	2,7	252,00	HW040+NMRV-P090	63B	6	8180
3,4	168	1,4	393,75	HW030+NMRV-P063	63A	4	6270
3,4	174	2,2	393,75	HW030+NMRV-P075	63A	4	7380
3,4	151	1,7	400,00	NMRV-P030/063	63A	4	6270
3,4	155	1,6	400,00	NMRV-P040/063	63A	4	6270
3,4	163	2,5	400,00	NMRV-P040/075	63A	4	7380
3,4	172	3,5	400,00	NMRV-P040/090	63A	4	8180
3,2	179	1,2	272,73	HW030+NMRV-P063	63B	6	6270
3,2	186	1,9	272,73	HW030+NMRV-P075	63B	6	7380
3,1	202	2,8	275,00	HW040+NMRV-P090	63B	6	8180
3,1	195	1,4	433,33	HW030+NMRV-P063	63A	4	6270
3,1	206	3,0	437,50	HW040+NMRV-P090	63A	4	8180
3,0	196	3,8	440,00	HW040+NMRV-P110	63A	4	10320
2,9	203	2,6	460,00	HW040+NMRV-P090	63A	4	8180
2,8	221	2,5	304,55	HW040+NMRV-P090	63B	6	8180
2,8	185	1,1	472,50	HW030+NMRV-P063	63A	4	6270
2,8	197	1,8	472,50	HW030+NMRV-P075	63A	4	7380
2,7	218	1,2	315,00	HW030+NMRV-P063	63B	6	6270
2,7	231	1,8	315,00	HW030+NMRV-P075	63B	6	7380
2,7	176	1,3	500,00	NMRV-P030/063	63A	4	6270
2,7	215	1,1	500,00	NMRV-P040/063	63A	4	6270
2,7	187	2,0	500,00	NMRV-P040/075	63A	4	7380
2,7	201	2,8	500,00	NMRV-P040/090	63A	4	8180
2,6	224	2,2	330,00	HW040+NMRV-P090	63B	6	8180
2,6	230	2,3	525,00	HW040+NMRV-P090	63A	4	8180
2,6	247	3,6	525,00	HW040+NMRV-P110	63A	4	10320
2,5	226	1,1	541,67	HW030+NMRV-P063	63A	4	6270
2,5	234	1,4	541,67	HW030+NMRV-P075	63A	4	7380
2,2	220	1,2	600,00	NMRV-P030/063	63A	4	6270
2,2	235	1,1	600,00	NMRV-P040/063	63A	4	6270
2,2	246	1,8	600,00	NMRV-P040/075	63A	4	7380
2,2	258	2,7	600,00	NMRV-P040/090	63A	4	8180
2,2	263	1,5	393,75	HW030+NMRV-P075	63B	6	7380
2,2	276	2,2	383,33	HW040+NMRV-P090	63B	6	8180
2,2	297	3,1	383,33	HW040+NMRV-P110	63B	6	10320
2,2	246	1,7	613,33	HW040+NMRV-P090	63A	4	8180

0,12 kW

n2 [rpm]	M2 [Nm]	fs	i	Gear reducer	Size	Motor Pole	Fr2 [N]
2,2	266	3,0	613,33	HW040+NMRV-P110	63A	4	10320
2,1	265	1,4	650,00	HW030+NMRV-P075	63A	4	7380
2,0	313	2,0	437,50	HW040+NMRV-P090	63B	6	8180
2,0	295	2,5	440,00	HW040+NMRV-P110	63B	6	10320
1,9	307	1,7	460,00	HW040+NMRV-P090	63B	6	8180
1,9	331	2,9	460,00	HW040+NMRV-P110	63B	6	10320
1,9	279	1,5	700,00	HW040+NMRV-P090	63A	4	8180
1,9	302	2,7	700,00	HW040+NMRV-P110	63A	4	10320
1,8	298	1,2	472,50	HW030+NMRV-P075	63B	6	7380
1,8	256	1,0	750,00	NMRV-P030/063	63A	4	6270
1,8	297	1,5	750,00	NMRV-P040/075	63A	4	7380
1,8	311	2,2	750,00	NMRV-P040/090	63A	4	8180
1,7	276	1,3	766,67	HW040+NMRV-P090	63A	4	8180
1,7	301	2,1	766,67	HW040+NMRV-P110	63A	4	10320
1,6	349	1,5	525,00	HW040+NMRV-P090	63B	6	8180
1,6	376	2,4	525,00	HW040+NMRV-P110	63B	6	10320
1,5	312	1,1	875,00	HW040+NMRV-P090	63A	4	8180
1,5	340	1,9	875,00	HW040+NMRV-P110	63A	4	10320
1,5	333	1,3	900,00	NMRV-P040/075	63A	4	7380
1,5	347	2,0	900,00	NMRV-P040/090	63A	4	8180
1,4	374	1,1	613,33	HW040+NMRV-P090	63B	6	8180
1,4	404	1,9	613,33	HW040+NMRV-P110	63B	6	10320
1,2	424	1,0	700,00	HW040+NMRV-P090	63B	6	8180
1,2	460	1,7	700,00	HW040+NMRV-P110	63B	6	10320
1,1	412	1,1	1200,00	NMRV-P040/075	63A	4	7380
1,1	431	1,6	1200,00	NMRV-P040/090	63A	4	8180
1,1	445	1,6	1200,00	NMRV-P050/090	63A	4	8180
1,1	445	2,8	1200,00	NMRV-P050/110	63A	4	10320
1,1	454	1,4	766,67	HW040+NMRV-P110	63B	6	10320
1,0	515	1,2	875,00	HW040+NMRV-P110	63B	6	10320
0,9	514	1,4	1500,00	NMRV-P040/090	63A	4	8180
0,9	523	1,3	1500,00	NMRV-P050/090	63A	4	8180
0,9	523	2,4	1500,00	NMRV-P050/110	63A	4	10320
0,7	578	1,2	1800,00	NMRV-P040/090	63A	4	8180
0,7	588	1,2	1800,00	NMRV-P050/090	63A	4	8180
0,7	588	2,1	1800,00	NMRV-P050/110	63A	4	10320
0,6	760	1,5	2400,00	NMRV-P050/110	63A	4	10320
0,5	907	1,2	3000,00	NMRV-P050/110	63A	4	10320
0,3	1088	1,0	4000,00	NMRV-P050/110	63A	4	10320

0,18 kW

n2 [rpm]	M2 [Nm]	fs	i	Gear reducer	Size	Motor Pole	Fr2 [N]
377,0	4	2,9	7,50	NMRV030	63A	2	542
283,0	5	2,2	10,00	NMRV030	63A	2	597
272,0	6	3,3	5,00	NMRV030	63B	4	597
189,0	8	1,6	15,00	NMRV030	63A	2	683
189,0	8	3,4	15,00	NMRV040	63A	2	1315
181,0	8	2,2	7,50	NMRV030	63B	4	683
141,5	10	1,2	20,00	NMRV030	63A	2	752
141,5	10	2,6	20,00	NMRV040	63A	2	1447
136,0	11	1,7	10,00	NMRV030	63B	4	752
120,0	12	3,3	7,50	NMRV040	71A	6	1524
113,2	12	1,2	25,00	NMRV030	63A	2	810
113,2	12	2,0	25,00	NMRV040	63A	2	1559
94,0	13	1,1	30,00	NMRV030	63A	2	861
94,0	14	2,2	30,00	NMRV040	63A	2	1657
91,0	15	1,2	15,00	NMRV030	63B	4	861
91,0	16	2,7	15,00	NMRV040	63B	4	1657
90,0	16	2,6	10,00	NMRV040	71A	6	1677
70,8	18	1,7	40,00	NMRV040	63A	2	1824
70,8	18	2,9	40,00	NMRV050	63A	2	2503
68,5	20	2,0	20,00	NMRV040	63B	4	1824
60,0	23	1,9	15,00	NMRV040	71A	6	1920
56,6	21	1,3	50,00	NMRV040	63A	2	1964
56,6	21	2,3	50,00	NMRV050	63A	2	2696
54,2	24	1,5	25,00	NMRV040	63B	4	1964
47,5	24	1,1	60,00	NMRV040	63A	2	2087
47,5	25	1,9	60,00	NMRV050	63A	2	2865
45,0	29	1,4	20,00	NMRV040	71A	6	2113
45,0	29	2,5	20,00	NMRV050	71A	6	2900
45,0	27	1,7	30,00	NMRV040	63B	4	2087
36,0	35	1,1	25,00	NMRV040	71A	6	2276
36,0	35	1,9	25,00	NMRV050	71A	6	3124
35,4	30	1,4	80,00	NMRV050	63A	2	3153
33,7	33	1,3	40,00	NMRV040	63B	4	2298
33,7	34	2,2	40,00	NMRV050	63B	4	3153
30,0	38	1,2	30,00	NMRV040	71A	6	2419
30,0	40	2,1	30,00	NMRV050	71A	6	3320
28,3	35	1,1	100,00	NMRV050	63A	2	3397
27,6	40	1,8	50,00	NMRV050	63B	4	3397
23,5	54	3,8	58,00	HW030+NMRV-P063	63B	4	4746
23,0	50	2,8	40,00	NMRV-P063	71A	6	4776
23,0	49	1,6	40,00	NMRV050	71A	6	3654
22,5	46	1,5	60,00	NMRV050	63B	4	3610

0,18 kW

n2 [rpm]	M2 [Nm]	fs	i	Gear reducer	Size	Motor Pole	Fr2 [N]
20,0	62	3,1	44,17	HW030+NMRV-P063	71A	6	4937
19,4	66	3,4	71,25	HW030+NMRV-P063	63B	4	5083
19,0	69	3,0	47,50	HW030+NMRV-P063	71A	6	5058
18,0	59	2,3	50,00	NMRV-P063	71A	6	5145
18,0	57	1,3	50,00	NMRV050	71A	6	3936
17,4	68	3,0	77,33	HW030+NMRV-P063	63B	4	5224
17,4	55	1,1	80,00	NMRV050	63B	4	3973
16,4	75	3,1	81,82	HW030+NMRV-P063	63B	4	5323
16,0	80	2,6	58,00	HW030+NMRV-P063	71A	6	5406
16,0	82	3,5	58,00	HW030+NMRV-P075	71A	6	6381
15,3	71	2,9	88,33	HW030+NMRV-P063	63B	4	5460
15,0	68	1,9	60,00	NMRV-P063	71A	6	5467
15,0	71	2,8	60,00	NMRV-P075	71A	6	6453
15,0	64	1,1	60,00	NMRV050	71A	6	4183
14,3	83	2,8	95,00	HW030+NMRV-P063	63B	4	5595
13,6	79	1,9	100,00	NMRV-P030/063	63B	4	4967
13,6	80	3,2	100,00	NMRV-P040/063	63B	4	4967
13,6	79	1,7	100,00	NMRV030/050	63B	4	3800
13,6	80	1,7	100,00	NMRV040/050	63B	4	3800
13,0	97	2,3	71,25	HW030+NMRV-P063	71A	6	5790
13,0	100	3,1	71,25	HW030+NMRV-P075	71A	6	6834
12,3	95	2,5	109,09	HW030+NMRV-P063	63B	4	5858
12,0	101	2,0	77,33	HW030+NMRV-P063	71A	6	5950
11,2	107	2,5	118,13	HW030+NMRV-P063	63B	4	6016
11,2	95	3,8	116,00	HW030+NMRV-P075	63B	4	7058
11,0	111	2,1	81,82	HW030+NMRV-P063	71A	6	6063
11,0	114	2,8	81,82	HW030+NMRV-P075	71A	6	7156
11,0	81	1,4	80,00	NMRV-P063	71A	6	6018
11,0	86	2,2	80,00	NMRV-P075	71A	6	7103
10,2	113	1,9	136,36	HW030+NMRV-P063	63B	4	6270
10,2	117	3,0	136,36	HW030+NMRV-P075	63B	4	7380
10,0	103	2,0	88,33	HW030+NMRV-P063	71A	6	6220
10,0	108	3,0	88,33	HW030+NMRV-P075	71A	6	7341
9,2	110	2,1	142,50	HW030+NMRV-P063	63B	4	6270
9,2	117	3,0	154,67	HW030+NMRV-P075	63B	4	7380
9,2	114	3,4	142,50	HW030+NMRV-P075	63B	4	7380
9,1	111	1,9	150,00	NMRV-P030/063	63B	4	5686
9,1	113	2,2	150,00	NMRV-P040/063	63B	4	5686
9,1	116	3,7	150,00	NMRV-P040/075	63B	4	6712
9,1	110	1,2	150,00	NMRV030/050	63B	4	4350
9,1	111	1,2	150,00	NMRV040/050	63B	4	4350
9,0	123	1,8	95,00	HW030+NMRV-P063	71A	6	6270

0,18 kW

n2 [rpm]	M2 [Nm]	fs	i	Gear reducer	Size	Motor Pole	Fr2 [N]
9,0	126	3,0	95,00	HW030+NMRV-P075	71A	6	7380
9,0	92	1,2	100,00	NMRV-P063	71A	6	6270
9,0	97	1,8	100,00	NMRV-P075	71A	6	7380
8,2	116	1,4	176,67	HW030+NMRV-P063	63B	4	6270
8,2	124	1,9	163,64	HW030+NMRV-P063	63B	4	6270
8,2	134	1,9	157,50	HW030+NMRV-P063	63B	4	6270
8,2	122	2,4	176,67	HW030+NMRV-P075	63B	4	7380
8,2	130	3,1	163,64	HW030+NMRV-P075	63B	4	7380
8,0	140	1,7	109,09	HW030+NMRV-P063	71A	6	6270
8,0	159	1,6	118,13	HW030+NMRV-P063	71A	6	6270
8,0	139	2,6	116,00	HW030+NMRV-P075	71A	6	7380
8,0	144	2,8	109,09	HW030+NMRV-P075	71A	6	7380
7,2	160	1,4	196,88	HW030+NMRV-P063	63B	4	6270
7,2	165	2,4	196,88	HW030+NMRV-P075	63B	4	7380
7,2	135	3,1	186,32	HW040+NMRV-P090	63B	4	8180
7,0	168	1,3	136,36	HW030+NMRV-P063	71A	6	6270
7,0	173	2,0	136,36	HW030+NMRV-P075	71A	6	7380
7,0	182	3,2	137,50	HW040+NMRV-P090	71A	6	8180
6,8	140	1,8	200,00	NMRV-P030/O63	63B	4	6259
6,8	143	1,7	200,00	NMRV-P040/O63	63B	4	6259
6,8	147	2,9	200,00	NMRV-P040/O75	63B	4	7380
6,8	154	4,0	200,00	NMRV-P040/O90	63B	4	8174
6,1	153	1,5	218,18	HW030+NMRV-P063	63B	4	6270
6,1	176	1,6	236,25	HW030+NMRV-P063	63B	4	6270
6,1	160	2,5	218,18	HW030+NMRV-P075	63B	4	7380
6,1	184	2,5	236,25	HW030+NMRV-P075	63B	4	7380
6,1	170	3,6	220,00	HW040+NMRV-P090	63B	4	8180
6,0	161	1,5	142,50	HW030+NMRV-P063	71A	6	6270
6,0	183	1,3	163,64	HW030+NMRV-P063	71A	6	6270
6,0	200	1,3	157,50	HW030+NMRV-P063	71A	6	6270
6,0	171	2,0	154,67	HW030+NMRV-P075	71A	6	7380
6,0	169	2,3	142,50	HW030+NMRV-P075	71A	6	7380
6,0	192	2,1	163,64	HW030+NMRV-P075	71A	6	7380
6,0	172	2,7	155,26	HW040+NMRV-P090	71A	6	8180
5,4	167	1,4	250,00	NMRV-P030/O63	63B	4	6270
5,4	171	1,3	250,00	NMRV-P040/O63	63B	4	6270
5,4	176	2,1	250,00	NMRV-P040/O75	63B	4	7380
5,4	184	3,1	250,00	NMRV-P040/O90	63B	4	8180
5,1	175	2,7	252,00	HW040+NMRV-P090	63B	4	8180
5,0	177	1,2	272,73	HW030+NMRV-P063	63B	4	6270
5,0	185	1,9	272,73	HW030+NMRV-P075	63B	4	7380
5,0	164	1,0	176,67	HW030+NMRV-P063	71A	6	6270

0,18 kW

n2 [rpm]	M2 [Nm]	fs	i	Gear reducer	Size	Motor Pole	Fr2 [N]
5,0	174	1,6	176,67	HW030+NMRV-P075	71A	6	7380
4,9	200	2,9	275,00	HW040+NMRV-P090	63B	4	8180
4,8	193	2,2	186,32	HW040+NMRV-P090	71A	6	8180
4,6	246	1,6	196,88	HW030+NMRV-P075	71A	6	7380
4,5	171	1,5	300,00	NMRV-P030/O63	63B	4	6270
4,5	187	1,4	300,00	NMRV-P040/O63	63B	4	6270
4,5	196	2,2	300,00	NMRV-P040/O75	63B	4	7380
4,5	205	3,4	300,00	NMRV-P040/O90	63B	4	8180
4,5	219	2,6	304,55	HW040+NMRV-P090	63B	4	8180
4,3	214	1,2	315,00	HW030+NMRV-P063	63B	4	6270
4,3	227	1,9	315,00	HW030+NMRV-P075	63B	4	7380
4,1	224	1,1	218,18	HW030+NMRV-P063	71A	6	6270
4,1	236	1,7	218,18	HW030+NMRV-P075	71A	6	7380
4,1	250	2,5	220,00	HW040+NMRV-P090	71A	6	8180
4,1	223	2,2	330,00	HW040+NMRV-P090	63B	4	8180
4,1	239	3,8	330,00	HW040+NMRV-P110	63B	4	10320
3,8	261	1,1	236,25	HW030+NMRV-P063	71A	6	6270
3,8	274	1,6	236,25	HW030+NMRV-P075	71A	6	7380
3,6	253	1,9	252,00	HW040+NMRV-P090	71A	6	8180
3,6	272	3,1	252,00	HW040+NMRV-P110	71A	6	10320
3,6	271	2,2	383,33	HW040+NMRV-P090	63B	4	8180
3,6	290	3,3	383,33	HW040+NMRV-P110	63B	4	10320
3,5	258	1,5	393,75	HW030+NMRV-P075	63B	4	7380
3,4	223	1,1	400,00	NMRV-P030/O63	63B	4	6270
3,4	229	1,1	400,00	NMRV-P040/O63	63B	4	6270
3,4	241	1,7	400,00	NMRV-P040/O75	63B	4	7380
3,4	253	2,5	400,00	NMRV-P040/O90	63B	4	8180
3,3	269	1,3	272,73	HW030+NMRV-P075	71A	6	7380
3,3	292	2,0	275,00	HW040+NMRV-P090	71A	6	8180
3,3	313	3,3	275,00	HW040+NMRV-P110	71A	6	10320
3,1	307	2,0	437,50	HW040+NMRV-P090	63B	4	8180
3,1	290	2,6	440,00	HW040+NMRV-P110	63B	4	10320
3,0	321	1,7	304,55	HW040+NMRV-P090	71A	6	8180
3,0	345	2,8	304,55	HW040+NMRV-P110	71A	6	10320
3,0	302	1,7	460,00	HW040+NMRV-P090	63B	4	8180
3,0	325	3,0	460,00	HW040+NMRV-P110	63B	4	10320
2,9	336	1,3	315,00	HW030+NMRV-P075	71A	6	7380
2,9	292	1,2	472,50	HW030+NMRV-P075	63B	4	7380
2,7	276	1,3	500,00	NMRV-P040/O75	63B	4	7380
2,7	296	1,9	500,00	NMRV-P040/O90	63B	4	8180
2,7	326	1,5	330,00	HW040+NMRV-P090	71A	6	8180
2,7	350	2,6	330,00	HW040+NMRV-P110	71A	6	10320

0,18 kW

n2 [rpm]	M2 [Nm]	fs	i	Gear reducer	Size	Motor Pole	Fr2 [N]
2,6	342	1,6	525,00	HW040+NMRV-P090	63B	4	8180
2,6	368	2,5	525,00	HW040+NMRV-P110	63B	4	10320
2,3	381	1,0	393,75	HW030+NMRV-P075	71A	6	7380
2,3	400	1,5	383,33	HW040+NMRV-P090	71A	6	8180
2,3	431	2,2	383,33	HW040+NMRV-P110	71A	6	10320
2,3	364	1,2	600,00	NMRV-P040/075	63B	4	7380
2,3	381	1,8	600,00	NMRV-P040/090	63B	4	8180
2,2	367	1,1	613,33	HW040+NMRV-P090	63B	4	8180
2,2	396	2,0	613,33	HW040+NMRV-P110	63B	4	10320
2,1	454	1,4	437,50	HW040+NMRV-P090	71A	6	8180
2,0	446	1,2	460,00	HW040+NMRV-P090	71A	6	8180
2,0	427	1,8	440,00	HW040+NMRV-P110	71A	6	10320
2,0	480	2,0	460,00	HW040+NMRV-P110	71A	6	10320
1,9	415	1,0	700,00	HW040+NMRV-P090	63B	4	8180
1,9	449	1,8	700,00	HW040+NMRV-P110	63B	4	10320
1,8	459	1,5	750,00	NMRV-P040/090	63B	4	8180
1,7	448	1,4	766,67	HW040+NMRV-P110	63B	4	10320
1,7	506	1,1	525,00	HW040+NMRV-P090	71A	6	8180
1,7	545	1,7	525,00	HW040+NMRV-P110	71A	6	10320
1,5	507	1,2	875,00	HW040+NMRV-P110	63B	4	10320
1,5	514	1,3	900,00	NMRV-P040/090	63B	4	8180
1,5	587	1,4	613,33	HW040+NMRV-P110	71A	6	10320
1,3	666	1,2	700,00	HW040+NMRV-P110	71A	6	10320
1,1	638	1,1	1200,00	NMRV-P040/090	63B	4	8180
1,1	656	1,0	1200,00	NMRV-P050/090	63B	4	8180
1,1	656	1,9	1200,00	NMRV-P050/110	63B	4	10320
0,9	773	1,6	1500,00	NMRV-P050/110	63B	4	10320
0,8	868	1,4	1800,00	NMRV-P050/110	63B	4	10320
0,6	1124	1,0	2400,00	NMRV-P050/110	63B	4	10320

0,25 kW

n2 [rpm]	M2 [Nm]	fs	i	Gear reducer	Size	Motor Pole	Fr2 [N]
564,0	4	3,0	5,00	NMRV030	63B	2	474
375,7	6	2,1	7,50	NMRV030	63B	2	542
282,0	7	1,6	10,00	NMRV030	63B	2	597
282,0	8	3,6	10,00	NMRV040	63B	2	1149
270,0	8	2,4	5,00	NMRV030	63D	4	597
188,3	10	1,1	15,00	NMRV030	63B	2	683
188,3	11	2,5	15,00	NMRV040	63B	2	1315
182,0	12	2,9	5,00	NMRV040	71B	6	1331
180,0	12	1,6	7,50	NMRV030	63D	4	683

0,25 kW

n2 [rpm]	M2 [Nm]	fs	i	Gear reducer	Motor		Fr2 [N]
					Size	Pole	
180,0	12	3,5	7,50	NMRV040	63D/71A	4	1315
141,0	14	1,9	20,00	NMRV040	63B	2	1447
138,0	15	2,9	10,00	NMRV040	63D/71A	4	1447
135,0	15	1,2	10,00	NMRV030	63D	4	752
121,3	17	2,4	7,50	NMRV040	71B	6	1524
112,8	17	1,4	25,00	NMRV040	63B	2	1559
93,7	20	1,6	30,00	NMRV040	63B	2	1657
92,3	21	3,6	15,00	NMRV050	71A	4	2274
91,0	22	1,9	10,00	NMRV040	71B	6	1677
90,0	22	1,9	15,00	NMRV040	63D/71A	4	1657
70,5	25	1,2	40,00	NMRV040	63B	2	1824
70,5	25	2,1	40,00	NMRV050	63B	2	2503
69,5	27	2,7	20,00	NMRV050	71A	4	2503
67,5	28	1,4	20,00	NMRV040	63D/71A	4	1824
60,7	31	1,3	15,00	NMRV040	71B	6	1920
60,7	32	2,4	15,00	NMRV050	71B	6	2635
56,4	30	1,7	50,00	NMRV050	63B	2	2696
55,6	34	3,7	25,00	NMRV-P063	71A	4	3524
55,6	33	2,0	25,00	NMRV050	71A	4	2696
54,2	33	1,1	25,00	NMRV040	63D/71A	4	1964
47,3	34	1,4	60,00	NMRV050	63B	2	2865
45,7	38	2,2	30,00	NMRV050	71A	4	2865
45,5	41	3,3	20,00	NMRV-P063	71B	6	3791
45,5	40	1,0	20,00	NMRV040	71B	6	2113
45,5	41	1,8	20,00	NMRV050	71B	6	2900
45,0	38	1,2	30,00	NMRV040	63D/71A	4	2087
36,4	49	2,5	25,00	NMRV-P063	71B	6	4084
36,4	48	1,4	25,00	NMRV050	71B	6	3124
35,2	42	1,0	80,00	NMRV050	63B	2	3153
34,8	54	3,6	38,67	HW030+NMRV-P063	63D/71A	4	4156
34,7	49	2,9	40,00	NMRV-P063	71A	4	4122
33,8	48	1,6	40,00	NMRV050	63D/71A	4	3153
31,3	61	3,1	29,00	HW030+NMRV-P063	71B	6	4291
30,7	59	3,2	44,17	HW030+NMRV-P063	63D/71A	4	4345
30,3	56	2,7	30,00	NMRV-P063	71B	6	4339
30,3	54	1,5	30,00	NMRV050	71B	6	3320
28,6	66	3,2	47,50	HW030+NMRV-P063	63D/71A	4	4452
27,8	58	2,4	50,00	NMRV-P063	71A	4	4440
27,8	60	3,5	50,00	NMRV-P075	71A	4	5241
26,6	57	1,3	50,00	NMRV050	63D/71A	4	3397
23,5	75	2,8	58,00	HW030+NMRV-P063	63D/71A	4	4758
23,3	78	2,4	38,67	HW030+NMRV-P063	71B	6	4722

0,25 kW

n2 [rpm]	M2 [Nm]	fs	i	Gear reducer	Motor		Fr2 [N]
					Size	Pole	
23,3	69	2,0	40,00	NMRV-P063	71B	6	4776
23,3	72	3,1	40,00	NMRV-P075	71B	6	5637
23,3	67	1,1	40,00	NMRV050	71B	6	3654
22,8	65	2,0	60,00	NMRV-P063	71A	4	4719
22,8	68	2,9	60,00	NMRV-P075	71A	4	5569
22,5	64	1,0	60,00	NMRV050	63D/71A	4	3610
20,2	85	2,2	44,17	HW030+NMRV-P063	71B	6	4937
20,2	87	3,0	44,17	HW030+NMRV-P075	71B	6	5827
19,4	92	2,4	71,25	HW030+NMRV-P063	63D/71A	4	5096
19,4	95	3,3	71,25	HW030+NMRV-P075	63D	4	6015
19,2	95	2,1	47,50	HW030+NMRV-P063	71B	6	5058
19,2	97	3,1	47,50	HW030+NMRV-P075	71B	6	5970
18,2	81	1,7	50,00	NMRV-P063	71B	6	5145
18,2	84	2,5	50,00	NMRV-P075	71B	6	6073
17,4	97	2,1	77,33	HW030+NMRV-P063	63D/71A	4	5237
17,4	99	3,5	77,33	HW030+NMRV-P075	63D/71A	4	6181
16,9	81	1,5	80,00	NMRV-P063	71A	4	5193
16,9	85	2,2	80,00	NMRV-P075	71A	4	6130
16,4	105	2,2	81,82	HW030+NMRV-P063	63D/71A	4	5336
16,4	108	3,0	81,82	HW030+NMRV-P075	63D/71A	4	6298
16,2	110	1,9	58,00	HW030+NMRV-P063	71B	6	5406
16,2	113	2,5	58,00	HW030+NMRV-P075	71B	6	6381
15,3	100	2,0	88,33	HW030+NMRV-P063	63D/71A	4	5474
15,3	104	3,2	88,33	HW030+NMRV-P075	63D/71A	4	6461
15,2	93	1,4	60,00	NMRV-P063	71B	6	5467
15,2	98	2,0	60,00	NMRV-P075	71B	6	6453
14,3	116	1,9	95,00	HW030+NMRV-P063	63D/71A	4	5609
14,3	120	3,2	95,00	HW030+NMRV-P075	63D/71A	4	6620
13,9	90	1,3	100,00	NMRV-P063	71A	4	5595
13,9	97	1,8	100,00	NMRV-P075	71A	4	6603
13,8	116	2,2	100,00	NMRV-P040/063	63D/71A	4	4967
13,8	117	3,0	100,00	NMRV-P040/075	63D/71A	4	5863
13,8	120	3,0	100,00	NMRV-P040/090	63D/71A	4	6487
13,8	116	1,2	100,00	NMRV040/050	63D/71A	4	3800
13,5	110	1,3	100,00	NMRV-P030/063	63D	4	4967
13,5	110	1,2	100,00	NMRV030/050	63D	4	3800
13,1	134	1,6	71,25	HW030+NMRV-P063	71B	6	5790
13,1	137	2,2	71,25	HW030+NMRV-P075	71B	6	6834
12,3	133	1,7	109,09	HW030+NMRV-P063	63D/71A	4	5873
12,3	137	3,0	109,09	HW030+NMRV-P075	63D/71A	4	6932
12,1	138	1,5	77,33	HW030+NMRV-P063	71B	6	5950
12,1	142	2,4	77,33	HW030+NMRV-P075	71B	6	7023

0,25 kW

n2 [rpm]	M2 [Nm]	fs	i	Gear reducer	Motor		Fr2 [N]
					Size	Pole	
11,2	150	1,7	118,13	HW030+NMRV-P063	63D/71A	4	6031
11,2	133	2,7	116,00	HW030+NMRV-P075	63D/71A	4	7076
11,1	153	1,5	81,82	HW030+NMRV-P063	71B	6	6063
11,1	157	2,0	81,82	HW030+NMRV-P075	71B	6	7156
11,1	111	1,0	80,00	NMRV-P063	71B	6	6018
11,1	118	1,5	80,00	NMRV-P075	71B	6	7103
10,2	159	1,3	136,36	HW030+NMRV-P063	63D/71A	4	6270
10,2	163	2,1	136,36	HW030+NMRV-P075	63D/71A	4	7380
10,2	171	3,5	137,50	HW040+NMRV-P090	63D/71A	4	8180
10,1	141	1,4	88,33	HW030+NMRV-P063	71B	6	6220
10,1	147	2,2	88,33	HW030+NMRV-P075	71B	6	7341
9,2	153	1,5	142,50	HW030+NMRV-P063	63D/71A	4	6270
9,2	163	2,1	154,67	HW030+NMRV-P075	63D/71A	4	7380
9,2	160	2,4	142,50	HW030+NMRV-P075	63D/71A	4	7380
9,2	168	2,8	155,26	HW040+NMRV-P090	63D/71A	4	8180
9,2	162	1,6	150,00	NMRV-P040/063	63D/71A	4	5686
9,2	166	2,6	150,00	NMRV-P040/075	63D/71A	4	6712
9,2	171	3,0	150,00	NMRV-P040/090	63D/71A	4	7426
9,2	175	3,8	150,00	NMRV-P050/090	71A	4	7426
9,1	169	1,3	95,00	HW030+NMRV-P063	71B	6	6270
9,1	174	2,2	95,00	HW030+NMRV-P075	71B	6	7380
9,1	134	1,3	100,00	NMRV-P075	71B	6	7380
9,0	154	1,3	150,00	NMRV-P030/063	63D	4	5686
8,2	174	1,4	163,64	HW030+NMRV-P063	63D/71A	4	6270
8,2	188	1,4	157,50	HW030+NMRV-P063	63D/71A	4	6270
8,2	182	2,1	163,64	HW030+NMRV-P075	63D/71A	4	7380
8,2	193	3,5	165,00	HW040+NMRV-P090	63D/71A	4	8180
8,1	193	1,2	109,09	HW030+NMRV-P063	71B	6	6270
8,1	219	1,2	118,13	HW030+NMRV-P063	71B	6	6270
8,1	191	1,8	116,00	HW030+NMRV-P075	71B	6	7380
8,1	198	2,0	109,09	HW030+NMRV-P075	71B	6	7380
8,1	209	2,8	110,00	HW040+NMRV-P090	71B	6	8180
7,2	162	1,0	176,67	HW030+NMRV-P063	63D/71A	4	6270
7,2	225	1,0	196,88	HW030+NMRV-P063	63D/71A	4	6270
7,2	171	1,6	176,67	HW030+NMRV-P075	63D/71A	4	7380
7,2	232	1,6	196,88	HW030+NMRV-P075	63D/71A	4	7380
7,2	189	2,2	186,32	HW040+NMRV-P090	63D/71A	4	8180
7,1	237	1,4	136,36	HW030+NMRV-P075	71B	6	7380
7,1	216	2,8	126,00	HW040+NMRV-P090	71B	6	8180
7,1	250	2,3	137,50	HW040+NMRV-P090	71B	6	8180
7,1	261	3,6	137,50	HW040+NMRV-P110	71B	6	10320
6,9	204	1,2	200,00	NMRV-P040/063	63D/71A	4	6259

0,25 kW

n2 [rpm]	M2 [Nm]	fs	i	Gear reducer	Motor		Fr2 [N]
					Size	Pole	
6,9	211	2,0	200,00	NMRV-P040/075	63D/71A	4	7380
6,9	219	2,8	200,00	NMRV-P040/090	63D/71A	4	8174
6,9	225	2,7	200,00	NMRV-P050/090	71A	4	8174
6,8	194	1,3	200,00	NMRV-P030/063	63D	4	6259
6,1	214	1,1	218,18	HW030+NMRV-P063	63D/71A	4	6270
6,1	245	1,1	236,25	HW030+NMRV-P063	63D/71A	4	6270
6,1	224	1,7	218,18	HW030+NMRV-P075	63D/71A	4	7380
6,1	258	1,7	236,25	HW030+NMRV-P075	63D/71A	4	7380
6,1	238	2,6	220,00	HW040+NMRV-P090	63D/71A	4	8180
6,1	221	1,1	142,50	HW030+NMRV-P063	71B	6	6270
6,1	234	1,5	154,67	HW030+NMRV-P075	71B	6	7380
6,1	231	1,6	142,50	HW030+NMRV-P075	71B	6	7380
6,1	264	1,5	163,64	HW030+NMRV-P075	71B	6	7380
6,1	236	2,0	155,26	HW040+NMRV-P090	71B	6	8180
6,0	257	3,3	252,00	HW040+NMRV-P110	71A	4	10320
5,5	252	1,5	250,00	NMRV-P040/075	63D/71A	4	7380
5,5	263	2,2	250,00	NMRV-P040/090	63D/71A	4	8180
5,5	269	2,1	250,00	NMRV-P050/090	71A	4	8180
5,1	245	1,9	252,00	HW040+NMRV-P090	63D/71A	4	8180
5,1	238	1,2	176,67	HW030+NMRV-P075	71B	6	7380
5,1	279	2,4	165,00	HW040+NMRV-P090	71B	6	8180
4,9	258	1,4	272,73	HW030+NMRV-P075	63D/71A	4	7380
4,9	279	2,0	275,00	HW040+NMRV-P090	63D/71A	4	8180
4,9	297	3,5	275,00	HW040+NMRV-P110	63D/71A	4	10320
4,9	265	1,6	186,32	HW040+NMRV-P090	71B	6	8180
4,9	284	2,6	186,32	HW040+NMRV-P110	71B	6	10320
4,7	338	1,1	196,88	HW030+NMRV-P075	71B	6	7380
4,6	267	1,0	300,00	NMRV-P040/063	63D/71A	4	6270
4,6	280	1,6	300,00	NMRV-P040/075	63D/71A	4	7380
4,6	293	2,4	300,00	NMRV-P040/090	63D/71A	4	8180
4,6	300	2,3	300,00	NMRV-P050/090	71A	4	8180
4,5	239	1,0	300,00	NMRV-P030/063	63D	4	6270
4,4	306	1,8	304,55	HW040+NMRV-P090	63D/71A	4	8180
4,4	327	3,0	304,55	HW040+NMRV-P110	63D/71A	4	10320
4,3	317	1,3	315,00	HW030+NMRV-P075	63D/71A	4	7380
4,1	324	1,2	218,18	HW030+NMRV-P075	71B	6	7380
4,1	344	1,8	220,00	HW040+NMRV-P090	71B	6	8180
4,1	360	3,1	220,00	HW040+NMRV-P110	71B	6	10320
4,1	312	1,6	330,00	HW040+NMRV-P090	63D/71A	4	8180
4,1	334	2,7	330,00	HW040+NMRV-P110	63D/71A	4	10320
3,8	376	1,2	236,25	HW030+NMRV-P075	71B	6	7380
3,6	348	1,3	252,00	HW040+NMRV-P090	71B	6	8180

0,25 kW

n2 [rpm]	M2 [Nm]	fs	i	Gear reducer	Motor		Fr2 [N]
					Size	Pole	
3,6	374	2,2	252,00	HW040+NMRV-P110	71B	6	10320
3,5	362	1,0	393,75	HW030+NMRV-P075	63D/71A	4	7380
3,5	379	1,6	383,33	HW040+NMRV-P090	63D/71A	4	8180
3,5	406	2,4	383,33	HW040+NMRV-P110	63D/71A	4	10320
3,5	344	1,2	400,00	NMRV-P040/075	63D/71A	4	7380
3,5	362	1,7	400,00	NMRV-P040/090	63D/71A	4	8180
3,5	371	1,7	400,00	NMRV-P050/090	71A	4	8180
3,5	389	3,1	400,00	NMRV-P050/110	71A	4	10320
3,5	389	3,1	400,00	NMRV-P063/110	71A	4	10320
3,3	401	1,4	275,00	HW040+NMRV-P090	71B	6	8180
3,3	429	2,4	275,00	HW040+NMRV-P110	71B	6	10320
3,1	429	1,4	437,50	HW040+NMRV-P090	63D/71A	4	8180
3,1	407	1,8	440,00	HW040+NMRV-P110	63D/71A	4	10320
3,0	441	1,2	304,55	HW040+NMRV-P090	71B	6	8180
3,0	474	2,0	304,55	HW040+NMRV-P110	71B	6	10320
3,0	423	1,2	460,00	HW040+NMRV-P090	63D/71A	4	8180
3,0	455	2,1	460,00	HW040+NMRV-P110	63D/71A	4	10320
2,8	423	1,3	500,00	NMRV-P040/090	63D/71A	4	8180
2,8	495	1,2	500,00	NMRV-P050/090	71A	4	8180
2,8	516	2,3	500,00	NMRV-P050/110	71A	4	10320
2,8	528	2,2	500,00	NMRV-P063/110	71A	4	10320
2,8	463	3,4	500,00	NMRV-P063/130	71A	4	13500
2,7	447	1,1	330,00	HW040+NMRV-P090	71B	6	8180
2,7	481	1,9	330,00	HW040+NMRV-P110	71B	6	10320
2,6	479	1,1	525,00	HW040+NMRV-P090	63D/71A	4	8180
2,6	515	1,7	525,00	HW040+NMRV-P110	63D/71A	4	10320
2,3	550	1,1	383,33	HW040+NMRV-P090	71B	6	8180
2,3	591	1,6	383,33	HW040+NMRV-P110	71B	6	10320
2,3	546	1,3	600,00	NMRV-P040/090	63D/71A	4	8180
2,3	552	1,3	600,00	NMRV-P050/090	71A	4	8180
2,3	552	2,3	600,00	NMRV-P050/110	71A	4	10320
2,3	566	2,3	600,00	NMRV-P063/110	71A	4	10320
2,3	575	3,1	600,00	NMRV-P063/130	71A	4	13500
2,2	554	1,4	613,33	HW040+NMRV-P110	63D/71A	4	10320
2,0	587	1,3	440,00	HW040+NMRV-P110	71B	6	10320
2,0	660	1,4	460,00	HW040+NMRV-P110	71B	6	10320
1,9	629	1,3	700,00	HW040+NMRV-P110	63D/71A	4	10320
1,8	656	1,1	750,00	NMRV-P040/090	63D/71A	4	8180
1,8	665	1,1	750,00	NMRV-P050/090	71A	4	8180
1,8	665	1,9	750,00	NMRV-P050/110	71A	4	10320
1,8	682	1,9	750,00	NMRV-P063/110	71A	4	10320
1,8	692	2,6	750,00	NMRV-P063/130	71A	4	13500

0,25 kW

n2 [rpm]	M2 [Nm]	fs	i	Gear reducer	Motor		Fr2 [N]
					Size	Pole	
1,8	671	3,5	750,00	NMRV-P063/150	71A	4	18000
1,8	613	1,0	766,67	HWO40+NMRV-P110	71A	4	10320
1,7	749	1,2	525,00	HWO40+NMRV-P110	71B	6	10320
1,5	756	1,7	900,00	NMRV-P050/110	71A	4	10320
1,5	777	1,6	900,00	NMRV-P063/110	71A	4	10320
1,5	789	2,2	900,00	NMRV-P063/130	71A	4	13500
1,5	846	2,5	900,00	NMRV-P063/150	71A	4	18000
1,2	939	1,4	1200,00	NMRV-P050/110	63D/71A	4	10320
1,2	980	1,3	1200,00	NMRV-P063/110	71A	4	10320
1,2	995	1,8	1200,00	NMRV-P063/130	71A	4	13500
1,2	1020	2,6	1200,00	NMRV-P063/150	71A	4	18000
0,9	1105	1,2	1500,00	NMRV-P050/110	63D/71A	4	10320
0,9	1156	1,1	1500,00	NMRV-P063/110	71A	4	10320
0,9	1173	1,5	1500,00	NMRV-P063/130	71A	4	13500
0,9	1198	2,0	1500,00	NMRV-P063/150	71A	4	18000
0,8	1243	1,0	1800,00	NMRV-P050/110	63D/71A	4	10320
0,8	1325	1,3	1800,00	NMRV-P063/130	71A	4	13500
0,8	1422	1,5	1800,00	NMRV-P063/150	71A	4	18000
0,6	1714	1,6	2400,00	NMRV-P063/150	71A	4	18000
0,5	2013	1,2	3000,00	NMRV-P063/150	71A	4	18000

0,37 kW

n2 [rpm]	M2 [Nm]	fs	i	Gear reducer	Motor		Fr2 [N]
					Size	Pole	
558,0	6	2,1	5,00	NMRV030	63C	2	474
372,0	8	1,4	7,50	NMRV030	63C	2	542
372,0	8	3,0	7,50	NMRV040	63C	2	1044
280,0	11	3,0	5,00	NMRV040	71B	4	1149
279,0	11	1,1	10,00	NMRV030	63C	2	597
279,0	11	2,4	10,00	NMRV040	63C	2	1149
186,7	17	2,4	7,50	NMRV040	71B	4	1315
186,0	16	1,7	15,00	NMRV040	63C	2	1315
180,0	17	1,9	5,00	NMRV040	71C	6	1331
140,0	22	1,9	10,00	NMRV040	71B	4	1447
140,0	21	1,3	20,00	NMRV040	63C	2	1447
140,0	22	3,4	10,00	NMRV050	71B	4	1987
119,7	25	1,6	7,50	NMRV040	71C	6	1524
119,7	25	2,9	7,50	NMRV050	71C/80A	6	2091
93,3	32	1,3	15,00	NMRV040	71B	4	1657
93,3	32	2,4	15,00	NMRV050	71B	4	2274
93,0	29	1,1	30,00	NMRV040	63C	2	1657
90,0	32	1,3	10,00	NMRV040	71C	6	1677

0,37 kW

n ₂ [rpm]	M ₂ [Nm]	f _s	i	Gear reducer	Motor		Fr ₂ [N]
					Size	Pole	
90,0	33	2,2	10,00	NMRV050	71C/80A	6	2302
70,0	41	3,3	20,00	NMRV-P063	71B	4	3272
70,0	39	1,0	20,00	NMRV040	71B	4	1824
70,0	40	1,8	20,00	NMRV050	71B	4	2503
70,0	37	1,4	40,00	NMRV050	63C	2	2503
62,9	46	3,8	22,08	HW030+NMRV-P063	71B	4	3398
60,3	48	2,9	15,00	NMRV-P063	71C/80A	6	3444
60,3	47	1,6	15,00	NMRV050	71C/80A	6	2635
56,0	44	1,1	50,00	NMRV050	63C	2	2696
55,8	50	2,5	25,00	NMRV-P063	71B	4	3524
55,8	48	1,4	25,00	NMRV050	71B	4	2696
48,7	60	3,1	29,00	HW030+NMRV-P063	71B	4	3721
46,7	57	2,6	30,00	NMRV-P063	71B	4	3745
46,7	55	1,5	30,00	NMRV050	71B	4	2865
45,0	62	2,2	20,00	NMRV-P063	71C/80A	6	3791
45,0	61	1,2	20,00	NMRV050	71C/80A	6	2900
40,9	70	2,5	22,08	HW030+NMRV-P063	71C/80A	6	3948
40,9	70	3,4	22,08	HW030+NMRV-P075	71C	6	4659
36,5	76	2,5	38,67	HW030+NMRV-P063	71B	4	4095
36,5	77	3,7	38,67	HW030+NMRV-P075	71B	4	4834
35,8	74	1,7	25,00	NMRV-P063	71C/80A	6	4084
35,8	76	2,7	25,00	NMRV-P075	71C/80A	6	4820
35,5	72	2,0	40,00	NMRV-P063	71B	4	4122
35,5	74	3,1	40,00	NMRV-P075	71B	4	4865
35,5	69	1,1	40,00	NMRV050	71B	4	3153
31,4	84	2,2	44,17	HW030+NMRV-P063	71B	4	4281
31,4	86	3,0	44,17	HW030+NMRV-P075	71B	4	5053
30,7	92	2,0	29,00	HW030+NMRV-P063	71C/80A	6	4323
30,7	92	3,0	29,00	HW030+NMRV-P075	71C/80A	6	5102
29,7	84	1,8	30,00	NMRV-P063	71C/80A	6	4339
29,7	87	2,7	30,00	NMRV-P075	71C/80A	6	5122
29,7	81	1,0	30,00	NMRV050	71C/80A	6	3320
29,4	93	2,2	47,50	HW030+NMRV-P063	71B	4	4386
29,4	94	3,1	47,50	HW030+NMRV-P075	71B	4	5177
28,4	85	1,6	50,00	NMRV-P063	71B	4	4440
28,4	89	2,4	50,00	NMRV-P075	71B	4	5241
24,3	108	1,9	58,00	HW030+NMRV-P063	71B	4	4688
24,3	111	2,6	58,00	HW030+NMRV-P075	71B	4	5533
23,5	116	1,6	38,67	HW030+NMRV-P063	71C/80A	6	4758
23,5	118	2,4	38,67	HW030+NMRV-P075	71C/80A	6	5616
23,3	96	1,3	60,00	NMRV-P063	71B	4	4719
23,3	100	2,0	60,00	NMRV-P075	71B	4	5569

0,37 kW

n2 [rpm]	M2 [Nm]	fs	i	Gear reducer	Motor		Fr2 [N]
					Size	Pole	
22,5	104	1,3	40,00	NMRV-P063	71C/80A	6	4776
22,5	109	2,1	40,00	NMRV-P075	71C/80A	6	5637
21,5	131	3,8	42,00	HW040+NMRV-P090	71C	6	6388
21,5	131	3,8	42,00	HW040+NMRV-P110	71C	6	8071
20,5	127	1,5	44,17	HW030+NMRV-P063	71C/80A	6	4974
20,5	130	2,0	44,17	HW030+NMRV-P075	71C/80A	6	5871
19,4	143	1,4	47,50	HW030+NMRV-P063	71C/80A	6	5096
19,4	145	2,0	47,50	HW030+NMRV-P075	71C/80A	6	6015
19,3	131	1,7	71,25	HW030+NMRV-P063	71B	4	5021
19,3	135	2,3	71,25	HW030+NMRV-P075	71B	4	5926
19,0	130	2,7	50,00	NMRV-P090	80A	6	6719
18,4	121	1,1	50,00	NMRV-P063	71C/80A	6	5145
18,4	125	1,6	50,00	NMRV-P075	71C/80A	6	6073
18,3	138	1,5	77,33	HW030+NMRV-P063	71B	4	5160
18,3	141	2,4	77,33	HW030+NMRV-P075	71B	4	6090
18,3	143	3,1	77,63	HW040+NMRV-P090	71B	4	6747
17,2	150	1,5	81,82	HW030+NMRV-P063	71B	4	5258
17,2	154	2,1	81,82	HW030+NMRV-P075	71B	4	6206
17,2	123	1,5	80,00	NMRV-P075	71B	4	6130
16,2	142	1,4	88,33	HW030+NMRV-P063	71B	4	5394
16,2	148	2,2	88,33	HW030+NMRV-P075	71B	4	6366
16,2	158	3,4	84,00	HW040+NMRV-P090	71B	4	6927
16,0	147	2,3	60,00	NMRV-P090	80A	6	7140
15,3	164	1,2	58,00	HW030+NMRV-P063	71C/80A	6	5447
15,3	169	1,7	58,00	HW030+NMRV-P075	71C/80A	6	6429
15,3	146	1,3	60,00	NMRV-P075	71C/80A	6	6453
15,2	167	1,3	95,00	HW030+NMRV-P063	71B	4	5526
15,2	172	2,2	95,00	HW030+NMRV-P075	71B	4	6523
15,2	163	3,4	93,16	HW040+NMRV-P090	71B	4	7170
14,3	188	3,1	63,00	HW040+NMRV-P090	71C/80A	6	7312
14,2	141	1,2	100,00	NMRV-P075	71B	4	6603
14,0	167	1,5	100,00	NMRV-P040/O63	71B	4	4967
14,0	170	2,1	100,00	NMRV-P040/O75	71B	4	5863
14,0	173	2,1	100,00	NMRV-P040/O90	71B	4	6487
14,0	177	3,3	100,00	NMRV-P050/O90	71B	4	6487
14,0	177	3,7	100,00	NMRV-P050/O110	71B	4	8198
13,2	189	1,2	109,09	HW030+NMRV-P063	71B	4	5787
13,2	195	2,0	109,09	HW030+NMRV-P075	71B	4	6830
13,2	204	2,9	110,00	HW040+NMRV-P090	71B	4	7579
12,3	200	1,1	71,25	HW030+NMRV-P063	71C/80A	6	5833
12,3	206	1,5	71,25	HW030+NMRV-P075	71C/80A	6	6885
12,2	213	1,2	118,13	HW030+NMRV-P063	71B	4	5942

0,37 kW

n2 [rpm]	M2 [Nm]	fs	i	Gear reducer	Motor		Fr2 [N]
					Size	Pole	
12,2	189	1,8	116,00	HW030+NMRV-P075	71B	4	6972
12,0	199	1,0	77,33	HW030+NMRV-P063	80A	6	5864
12,0	180	1,5	80,00	NMRV-P090	80A	6	7859
12,0	192	2,5	80,00	NMRV-P110	80A	6	9931
11,2	214	1,6	77,33	HW030+NMRV-P075	71C/80A	6	7076
11,2	236	1,3	81,82	HW030+NMRV-P075	71C/80A	6	7210
11,2	216	2,0	77,63	HW040+NMRV-P090	71C/80A	6	7839
11,2	176	1,0	80,00	NMRV-P075	71C/80A	6	7103
11,2	214	2,8	126,00	HW040+NMRV-P090	71B	4	7930
11,0	219	1,1	81,82	HW030+NMRV-P063	80A	6	5976
10,2	221	1,4	88,33	HW030+NMRV-P075	71C/80A	6	7380
10,2	241	2,2	84,00	HW040+NMRV-P090	71C/80A	6	8048
10,2	247	3,8	84,00	HW040+NMRV-P110	71C	6	10169
10,1	218	1,1	142,50	HW030+NMRV-P063	71B	4	6270
10,1	229	1,6	142,50	HW030+NMRV-P075	71B	4	7380
10,1	234	1,5	136,36	HW030+NMRV-P075	71B	4	7358
10,1	244	2,4	137,50	HW040+NMRV-P090	71B	4	8164
10,1	255	3,7	137,50	HW040+NMRV-P110	71B	4	10316
9,3	235	1,1	150,00	NMRV-P040/063	71B	4	5686
9,3	242	1,7	150,00	NMRV-P040/075	71B	4	6712
9,3	247	2,1	150,00	NMRV-P040/090	71B	4	7426
9,3	253	2,6	150,00	NMRV-P050/090	71B	4	7426
9,3	256	3,7	150,00	NMRV-P050/110	71B	4	9384
9,2	260	1,4	95,00	HW030+NMRV-P075	71C/80A	6	7380
9,2	243	2,2	93,16	HW040+NMRV-P090	71C/80A	6	8180
9,1	234	1,5	154,67	HW030+NMRV-P075	71B	4	7380
9,1	240	1,9	155,26	HW040+NMRV-P090	71B	4	8180
9,1	251	3,2	155,26	HW040+NMRV-P110	71B	4	10320
9,0	207	1,2	100,00	NMRV-P090	80A	6	8180
9,0	222	2,1	100,00	NMRV-P110	80A	6	10320
8,2	286	1,2	116,00	HW030+NMRV-P075	71C/80A	6	7380
8,2	296	1,3	109,09	HW030+NMRV-P075	71C/80A	6	7380
8,2	312	1,9	110,00	HW040+NMRV-P090	71C/80A	6	8180
8,2	301	3,4	105,00	HW040+NMRV-P110	71C	6	10320
8,1	244	1,1	176,67	HW030+NMRV-P075	71B	4	7380
8,1	260	1,5	163,64	HW030+NMRV-P075	71B	4	7380
8,1	274	2,4	165,00	HW040+NMRV-P090	71B	4	8180
8,1	278	3,7	168,00	HW040+NMRV-P110	71B	4	10320
7,2	323	1,9	126,00	HW040+NMRV-P090	71C/80A	6	8180
7,2	323	3,5	126,00	HW040+NMRV-P110	71C	6	10320
7,1	331	1,2	196,88	HW030+NMRV-P075	71B	4	7380
7,1	269	1,5	186,32	HW040+NMRV-P090	71B	4	8180

0,37 kW

n2 [rpm]	M2 [Nm]	fs	i	Gear reducer	Motor Size	Pole	Fr2 [N]
7,1	288	2,5	186,32	HW040+NMRV-P110	71B	4	10320
7,0	340	1,0	136,36	HW030+NMRV-P075	80A	6	7380
7,0	305	1,4	200,00	NMRV-P040/075	71B	4	7380
7,0	317	1,9	200,00	NMRV-P040/090	71B	4	8174
7,0	324	1,9	200,00	NMRV-P050/090	71B	4	8174
7,0	333	3,4	200,00	NMRV-P050/110	71B	4	10320
7,0	333	3,4	200,00	NMRV-P063/110	71B	4	10320
6,1	346	1,1	142,50	HW030+NMRV-P075	71C/80A	6	7380
6,1	354	1,3	155,26	HW040+NMRV-P090	71C/80A	6	8180
6,1	375	1,5	137,50	HW040+NMRV-P090	71C/80A	6	8180
6,1	375	2,2	155,26	HW040+NMRV-P110	71C/80A	6	10320
6,1	390	2,5	137,50	HW040+NMRV-P110	71C/80A	6	10320
6,1	320	1,2	218,18	HW030+NMRV-P075	71B	4	7380
6,1	368	1,2	236,25	HW030+NMRV-P075	71B	4	7380
6,1	339	1,8	220,00	HW040+NMRV-P090	71B	4	8180
6,1	356	3,1	220,00	HW040+NMRV-P110	71B	4	10320
6,0	336	1,0	154,67	HW030+NMRV-P075	80A	6	7380
6,0	378	1,1	163,64	HW030+NMRV-P075	80A	6	7380
5,6	365	1,0	250,00	NMRV-P040/075	71B	4	7380
5,6	380	1,5	250,00	NMRV-P040/090	71B	4	8180
5,6	389	1,4	250,00	NMRV-P050/090	71B	4	8180
5,6	406	2,8	250,00	NMRV-P050/110	71B	4	10320
5,6	406	2,8	250,00	NMRV-P063/110	71B	4	10320
5,6	406	3,8	250,00	NMRV-P063/130	71B	4	13500
5,1	418	1,6	165,00	HW040+NMRV-P090	71C/80A	6	8180
5,1	418	2,5	168,00	HW040+NMRV-P110	71C/80A	6	10320
5,1	350	1,3	252,00	HW040+NMRV-P090	71B	4	8180
5,1	398	1,4	275,00	HW040+NMRV-P090	71B	4	8180
5,1	375	2,2	252,00	HW040+NMRV-P110	71B	4	10320
5,1	424	2,4	275,00	HW040+NMRV-P110	71B	4	10320
4,8	396	1,0	186,32	HW040+NMRV-P090	71C/80A	6	8180
4,8	424	1,7	186,32	HW040+NMRV-P110	71C/80A	6	10320
4,7	406	1,1	300,00	NMRV-P040/075	71B	4	7380
4,7	425	1,6	300,00	NMRV-P040/090	71B	4	8180
4,7	435	1,6	300,00	NMRV-P050/090	71B	4	8180
4,7	435	2,9	300,00	NMRV-P050/110	71B	4	10320
4,7	435	2,9	300,00	NMRV-P063/110	71B	4	10320
4,7	442	4,0	300,00	NMRV-P063/130	71B	4	13500
4,6	437	1,2	304,55	HW040+NMRV-P090	71B	4	8180
4,6	466	2,1	304,55	HW040+NMRV-P110	71B	4	10320
4,3	446	1,1	330,00	HW040+NMRV-P090	71B	4	8180
4,3	477	1,9	330,00	HW040+NMRV-P110	71B	4	10320

0,37 kW

n2 [rpm]	M2 [Nm]	fs	i	Gear reducer	Motor		Fr2 [N]
					Size	Pole	
4,1	514	1,2	220,00	HW040+NMRV-P090	71C/80A	6	8180
4,1	539	2,0	220,00	HW040+NMRV-P110	71C/80A	6	10320
3,7	541	1,1	383,33	HW040+NMRV-P090	71B	4	8180
3,7	580	1,6	383,33	HW040+NMRV-P110	71B	4	10320
3,6	559	1,5	252,00	HW040+NMRV-P110	71C/80A	6	10320
3,5	524	1,1	400,00	NMRV-P040/090	71B	4	8180
3,5	537	1,1	400,00	NMRV-P050/090	71B	4	8180
3,5	563	2,1	400,00	NMRV-P050/110	71B	4	10320
3,5	563	2,1	400,00	NMRV-P063/110	71B	4	10320
3,5	563	2,9	400,00	NMRV-P063/130	71B	4	13500
3,3	643	1,6	275,00	HW040+NMRV-P110	71C/80A	6	10320
3,2	613	1,0	437,50	HW040+NMRV-P090	71B	4	8180
3,1	581	1,3	440,00	HW040+NMRV-P110	71B	4	10320
3,0	650	1,5	460,00	HW040+NMRV-P110	71B	4	10320
3,0	709	1,3	304,55	HW040+NMRV-P110	71C/80A	6	10320
2,8	746	1,5	500,00	NMRV-P050/110	71B	4	10320
2,8	765	1,5	500,00	NMRV-P063/110	71B	4	10320
2,8	671	2,3	500,00	NMRV-P063/130	71B	4	13500
2,8	671	3,4	500,00	NMRV-P063/150	71B	4	18000
2,8	720	1,2	330,00	HW040+NMRV-P110	71C/80A	6	10320
2,6	735	1,2	525,00	HW040+NMRV-P110	71B	4	10320
2,4	885	1,0	383,33	HW040+NMRV-P110	71C/80A	6	10320
2,3	800	1,6	600,00	NMRV-P050/110	71B	4	10320
2,3	820	1,5	600,00	NMRV-P063/110	71B	4	10320
2,3	832	2,1	600,00	NMRV-P063/130	71B	4	13500
2,3	828	3,2	600,00	NMRV-P063/150	71B	4	18000
2,0	945	1,0	460,00	HW040+NMRV-P110	80A	6	10320
1,9	963	1,3	750,00	NMRV-P050/110	71B	4	10320
1,9	988	1,3	750,00	NMRV-P063/110	71B	4	10320
1,9	1003	1,7	750,00	NMRV-P063/130	71B	4	13500
1,9	972	2,4	750,00	NMRV-P063/150	71B	4	18000
1,6	1095	1,1	900,00	NMRV-P050/110	71B	4	10320
1,6	1125	1,1	900,00	NMRV-P063/110	71B	4	10320
1,6	1141	1,5	900,00	NMRV-P063/130	71B	4	13500
1,6	1226	1,7	900,00	NMRV-P063/150	71B	4	18000
1,2	1441	1,2	1200,00	NMRV-P063/130	71B	4	13500
1,2	1478	1,8	1200,00	NMRV-P063/150	71B	4	18000
0,9	1700	1,0	1500,00	NMRV-P063/130	71B	4	13500
0,9	1735	1,3	1500,00	NMRV-P063/150	71B	4	18000
0,8	2059	1,0	1800,00	NMRV-P063/150	71B	4	18000
0,6	2483	1,1	2400,00	NMRV-P063/150	71B	4	18000

0,55 kW

n2 [rpm]	M2 [Nm]	fs	i	Gear reducer	Motor		Fr2 [N]
					Size	Pole	
566,0	8	2,5	5,00	NMRV040	71B	2	912
377,7	12	2,0	7,50	NMRV040	71B	2	1044
283,0	16	1,6	10,00	NMRV040	71B	2	1149
283,0	17	2,9	10,00	NMRV050	71B	2	1577
280,0	17	2,0	5,00	NMRV040	71C	4	1149
280,0	17	3,9	5,00	NMRV050	71C	4	1577
189,7	25	2,9	7,50	NMRV050	71C/80A	4	1805
188,3	24	1,1	15,00	NMRV040	71B	2	1315
188,3	24	2,0	15,00	NMRV050	71B	2	1805
188,0	25	2,6	5,00	NMRV050	80B	6	1827
187,0	24	1,6	7,50	NMRV040	71C	4	1315
142,0	31	1,5	20,00	NMRV050	71B	2	1987
142,0	33	2,3	10,00	NMRV050	71C/80A	4	1987
140,0	32	1,3	10,00	NMRV040	71C	4	1447
125,3	36	2,0	7,50	NMRV050	80B	6	2091
112,8	38	1,2	25,00	NMRV050	71B	2	2140
94,7	43	1,3	30,00	NMRV050	71B	2	2274
94,0	47	2,6	10,00	NMRV-P063	80B	6	3009
94,0	47	1,6	10,00	NMRV050	80B	6	2302
93,0	47	3,0	15,00	NMRV-P063	71C/80A	4	2973
93,0	47	1,6	15,00	NMRV050	71C/80A	4	2274
70,5	62	2,2	20,00	NMRV-P063	71C/80A	4	3272
70,5	63	3,6	20,00	NMRV-P075	71C/80A	4	3862
70,5	60	1,2	20,00	NMRV050	71C/80A	4	2503
63,4	69	2,6	22,08	HW030+NMRV-P063	71C/80A	4	3406
63,4	69	3,6	22,08	HW030+NMRV-P075	71C/80A	4	4020
62,7	68	2,0	15,00	NMRV-P063	80B	6	3444
62,7	69	3,1	15,00	NMRV-P075	80B	6	4065
62,7	67	1,1	15,00	NMRV050	80B	6	2635
56,2	74	1,7	25,00	NMRV-P063	71C/80A	4	3524
56,2	76	2,7	25,00	NMRV-P075	71C/80A	4	4160
48,0	89	2,1	29,00	HW030+NMRV-P063	71C/80A	4	3730
48,0	89	3,1	29,00	HW030+NMRV-P075	71C/80A	4	4403
47,5	87	1,6	20,00	NMRV-P063	80B	6	3791
47,5	89	2,4	20,00	NMRV-P075	80B	6	4474
47,0	84	1,8	30,00	NMRV-P063	71C/80A	4	3745
47,0	87	2,7	30,00	NMRV-P075	71C/80A	4	4421
47,0	82	1,0	30,00	NMRV050	71C/80A	4	2865
42,5	101	1,7	22,08	HW030+NMRV-P063	80B	6	3876
42,5	100	2,4	22,08	HW030+NMRV-P075	80B	6	4574
40,4	107	3,8	23,29	HW040+NMRV-P090	80B	6	5152
40,4	107	3,8	23,29	HW040+NMRV-P110	80B	6	6510

0,55 kW

n2 [rpm]	M2 [Nm]	fs	i	Gear reducer	Motor Size	Pole	Fr2 [N]
37,4	106	1,2	25,00	NMRV-P063	80B	6	4084
37,4	109	1,8	25,00	NMRV-P075	80B	6	4820
37,4	112	3,1	25,00	NMRV-P090	80B	6	5333
35,8	114	1,6	38,67	HW030+NMRV-P063	71C/80A	4	4105
35,8	114	2,5	38,67	HW030+NMRV-P075	71C/80A	4	4846
35,5	112	3,3	40,00	NMRV-P090	80A	4	5383
34,7	107	1,3	40,00	NMRV-P063	71C/80A	4	4122
34,7	110	2,1	40,00	NMRV-P075	71C/80A	4	4865
33,7	127	3,9	42,00	HW040+NMRV-P090	71C/80A	4	5511
33,7	127	3,9	42,00	HW040+NMRV-P110	71C/80A	4	6964
32,3	131	1,4	29,00	HW030+NMRV-P063	80B	6	4244
32,3	131	2,0	29,00	HW030+NMRV-P075	80B	6	5009
31,7	125	1,5	44,17	HW030+NMRV-P063	71C/80A	4	4291
31,7	128	2,0	44,17	HW030+NMRV-P075	71C/80A	4	5065
31,3	119	1,3	30,00	NMRV-P063	80B	6	4339
31,3	124	1,8	30,00	NMRV-P075	80B	6	5122
31,3	128	3,2	30,00	NMRV-P090	80B	6	5667
30,3	140	3,3	31,05	HW040+NMRV-P090	80B	6	5671
30,3	140	3,8	31,05	HW040+NMRV-P110	80B	6	7165
29,6	138	1,5	47,50	HW030+NMRV-P063	71C/80A	4	4397
29,6	140	2,1	47,50	HW030+NMRV-P075	71C/80A	4	5190
29,6	138	3,8	46,58	HW040+NMRV-P090	71C	4	5705
28,4	135	2,6	50,00	NMRV-P090	80A	4	5799
27,6	125	1,1	50,00	NMRV-P063	71C/80A	4	4440
27,6	131	1,6	50,00	NMRV-P075	71C/80A	4	5241
24,5	160	1,3	58,00	HW030+NMRV-P063	71C/80A	4	4699
24,5	165	1,7	58,00	HW030+NMRV-P075	71C/80A	4	5547
24,3	166	1,1	38,67	HW030+NMRV-P063	80B	6	4671
24,3	168	1,6	38,67	HW030+NMRV-P075	80B	6	5513
23,5	149	1,3	60,00	NMRV-P075	71C/80A	4	5569
23,3	156	2,1	60,00	NMRV-P090	80A	4	6163
23,3	165	3,5	60,00	NMRV-P110	80A	4	7787
23,2	154	1,5	40,00	NMRV-P075	80B	6	5637
23,2	161	2,3	40,00	NMRV-P090	80B	6	6238
22,5	183	3,2	63,00	HW040+NMRV-P090	71C/80A	4	6309
22,2	187	2,6	42,00	HW040+NMRV-P090	80B	6	6271
22,2	187	2,6	42,00	HW040+NMRV-P110	80B	6	7924
21,2	180	1,0	44,17	HW030+NMRV-P063	80B	6	4883
21,2	185	1,4	44,17	HW030+NMRV-P075	80B	6	5763
20,2	206	1,4	47,50	HW030+NMRV-P075	80B	6	5905
20,2	200	2,6	46,58	HW040+NMRV-P090	80B	6	6491
20,2	203	3,8	46,58	HW040+NMRV-P110	80B	6	8202

0,55 kW

n2 [rpm]	M2 [Nm]	fs	i	Gear reducer	Motor		Fr2 [N]
					Size	Pole	
19,4	195	1,1	71,25	HW030+NMRV-P063	71C/80A	4	5033
19,4	201	1,5	71,25	HW030+NMRV-P075	71C/80A	4	5941
19,2	179	1,2	50,00	NMRV-P075	80B	6	6073
19,2	193	1,8	50,00	NMRV-P090	80B	6	6719
19,2	201	3,1	50,00	NMRV-P110	80B	6	8491
18,4	210	1,6	77,33	HW030+NMRV-P075	71C/80A	4	6105
18,4	213	2,0	77,63	HW040+NMRV-P090	71C/80A	4	6764
18,3	202	1,0	77,33	HW030+NMRV-P063	80A	4	5135
18,3	180	1,0	80,00	NMRV-P075	80A	4	6130
18,3	189	1,4	80,00	NMRV-P090	80A	4	6783
18,3	201	2,4	80,00	NMRV-P110	80A	4	8571
17,4	222	1,0	81,82	HW030+NMRV-P063	71C/80A	4	5270
17,4	229	1,4	81,82	HW030+NMRV-P075	71C/80A	4	6221
16,4	220	1,4	88,33	HW030+NMRV-P075	71C/80A	4	6382
16,4	235	2,4	84,00	HW040+NMRV-P090	71C/80A	4	6944
16,4	241	3,9	84,00	HW040+NMRV-P110	71C/80A	4	8774
16,2	240	1,2	58,00	HW030+NMRV-P075	80B	6	6311
16,2	218	1,5	60,00	NMRV-P090	80B	6	7140
16,2	232	2,5	60,00	NMRV-P110	80B	6	9023
15,3	242	2,4	93,16	HW040+NMRV-P090	71C/80A	4	7188
15,2	267	2,1	63,00	HW040+NMRV-P090	80B	6	7179
15,2	263	2,9	62,11	HW040+NMRV-P110	80B	6	9028
14,3	254	1,5	95,00	HW030+NMRV-P075	71C/80A	4	6538
14,2	264	2,2	100,00	NMRV-P050/090	71C/80A	4	6487
14,2	264	2,4	100,00	NMRV-P050/110	71C/80A	4	8198
14,2	222	1,1	100,00	NMRV-P090	80A	4	7306
14,2	237	1,9	100,00	NMRV-P110	80A	4	9232
14,0	247	1,0	100,00	NMRV-P040/063	71C	4	4967
14,0	250	1,4	100,00	NMRV-P040/075	71C	4	5863
14,0	255	1,4	100,00	NMRV-P040/090	71C	4	6487
13,3	290	1,3	109,09	HW030+NMRV-P075	71C/80A	4	6847
13,3	294	3,5	105,00	HW040+NMRV-P110	71C/80A	4	9452
13,1	293	1,0	71,25	HW030+NMRV-P075	80B	6	6759
12,3	282	1,2	116,00	HW030+NMRV-P075	71C/80A	4	6989
12,3	303	1,9	110,00	HW040+NMRV-P090	71C/80A	4	7597
12,1	304	1,1	77,33	HW030+NMRV-P075	80B	6	6947
12,1	308	1,4	77,63	HW040+NMRV-P090	80B	6	7696
12,1	321	2,6	77,63	HW040+NMRV-P110	80B	6	9725
12,1	286	1,7	80,00	NMRV-P110	80B	6	9931
11,2	317	1,9	126,00	HW040+NMRV-P090	71C/80A	4	7949
11,2	319	3,5	126,00	HW040+NMRV-P110	71C/80A	4	10044
11,1	315	1,0	88,33	HW030+NMRV-P075	80B	6	7261

0,55 kW

n2 [rpm]	M2 [Nm]	fs	i	Gear reducer	Motor		Fr2 [N]
					Size	Pole	
11,1	342	1,6	84,00	HW040+NMRV-P090	80B	6	7901
11,1	351	2,6	84,00	HW040+NMRV-P110	80B	6	9984
10,2	341	1,1	142,50	HW030+NMRV-P075	71C/80A	4	7380
10,2	364	1,6	137,50	HW040+NMRV-P090	71C/80A	4	8180
10,2	379	2,5	137,50	HW040+NMRV-P110	71C/80A	4	10320
10,1	370	1,0	95,00	HW030+NMRV-P075	80B	6	7380
10,1	346	1,6	93,16	HW040+NMRV-P090	80B	6	8178
10,1	347	2,6	93,16	HW040+NMRV-P110	80B	6	10320
9,5	377	1,7	150,00	NMRV-P050/090	71C/80A	4	7426
9,5	382	2,4	150,00	NMRV-P050/110	71C/80A	4	9384
9,5	382	3,1	150,00	NMRV-P063/110	71C/80A	4	9384
9,3	356	1,2	150,00	NMRV-P040/075	71C	4	6712
9,3	365	1,4	150,00	NMRV-P040/090	71C	4	7426
9,2	356	1,3	155,26	HW040+NMRV-P090	71C/80A	4	8180
9,2	374	2,2	155,26	HW040+NMRV-P110	71C/80A	4	10320
9,1	342	1,0	154,67	HW030+NMRV-P075	80A	4	7380
9,1	428	2,3	105,00	HW040+NMRV-P110	80B	6	10320
9,1	329	1,4	100,00	NMRV-P110	80B	6	10320
8,2	387	1,0	163,64	HW030+NMRV-P075	71C/80A	4	7380
8,2	408	1,6	165,00	HW040+NMRV-P090	71C/80A	4	8180
8,2	414	2,5	168,00	HW040+NMRV-P110	71C/80A	4	10320
8,1	444	1,3	110,00	HW040+NMRV-P090	80B	6	8180
7,2	400	1,0	186,32	HW040+NMRV-P090	71C/80A	4	8180
7,2	428	1,7	186,32	HW040+NMRV-P110	71C/80A	4	10320
7,1	483	1,2	200,00	NMRV-P050/090	71C/80A	4	8174
7,1	496	2,3	200,00	NMRV-P050/110	71C/80A	4	10320
7,1	496	2,3	200,00	NMRV-P063/110	71C/80A	4	10320
7,1	496	3,2	200,00	NMRV-P063/130	71C/80A	4	13500
7,1	459	1,3	126,00	HW040+NMRV-P090	80B	6	8180
7,1	533	1,1	137,50	HW040+NMRV-P090	80B	6	8180
7,1	459	2,4	126,00	HW040+NMRV-P110	80B	6	10320
7,1	555	1,7	137,50	HW040+NMRV-P110	80B	6	10320
7,0	468	1,3	200,00	NMRV-P040/090	71C	4	8174
6,1	504	1,2	220,00	HW040+NMRV-P090	71C/80A	4	8180
6,1	529	2,1	220,00	HW040+NMRV-P110	71C/80A	4	10320
6,1	594	1,1	165,00	HW040+NMRV-P090	80B	6	8180
6,1	534	1,5	155,26	HW040+NMRV-P110	80B	6	10320
6,1	595	1,7	168,00	HW040+NMRV-P110	80B	6	10320
5,7	603	1,9	250,00	NMRV-P050/110	71C/80A	4	10320
5,7	603	1,9	250,00	NMRV-P063/110	71C/80A	4	10320
5,7	603	2,5	250,00	NMRV-P063/130	71C/80A	4	13500
5,7	603	3,3	250,00	NMRV-P063/150	71C/80A	4	18000

0,55 kW

n2 [rpm]	M2 [Nm]	fs	i	Gear reducer	Motor		Fr2 [N]
					Size	Pole	
5,1	557	1,5	252,00	HWO40+NMRV-P110	71C/80A	4	10320
5,1	629	1,6	275,00	HWO40+NMRV-P110	71C/80A	4	10320
5,1	604	1,2	186,32	HWO40+NMRV-P110	80B	6	10320
4,7	647	1,1	300,00	NMRV-P050/090	71C/80A	4	8180
4,7	647	1,9	300,00	NMRV-P050/110	71C/80A	4	10320
4,7	647	1,9	300,00	NMRV-P063/110	71C/80A	4	10320
4,7	657	2,6	300,00	NMRV-P063/130	71C/80A	4	13500
4,7	718	3,2	300,00	NMRV-P063/150	71C/80A	4	18000
4,7	627	1,1	300,00	NMRV-P040/090	71C	4	8180
4,6	693	1,4	304,55	HWO40+NMRV-P110	71C/80A	4	10320
4,3	709	1,2	330,00	HWO40+NMRV-P110	71C/80A	4	10320
4,2	767	1,4	220,00	HWO40+NMRV-P110	80B	6	10320
3,7	796	1,0	252,00	HWO40+NMRV-P110	80B	6	10320
3,7	861	1,1	383,33	HWO40+NMRV-P110	71C/80A	4	10320
3,5	837	1,4	400,00	NMRV-P050/110	71C/80A	4	10320
3,5	837	1,4	400,00	NMRV-P063/110	71C/80A	4	10320
3,5	837	1,9	400,00	NMRV-P063/130	71C/80A	4	13500
3,5	850	3,1	400,00	NMRV-P063/150	71C/80A	4	18000
3,4	915	1,1	275,00	HWO40+NMRV-P110	80B	6	10320
2,8	1110	1,0	500,00	NMRV-P050/110	71C/80A	4	10320
2,8	1138	1,0	500,00	NMRV-P063/110	71C/80A	4	10320
2,8	998	1,5	500,00	NMRV-P063/130	71C/80A	4	13500
2,8	998	2,3	500,00	NMRV-P063/150	71C/80A	4	18000
2,4	1190	1,0	600,00	NMRV-P050/110	71C/80A	4	10320
2,4	1220	1,0	600,00	NMRV-P063/110	71C/80A	4	10320
2,4	1237	1,4	600,00	NMRV-P063/130	71C/80A	4	13500
2,4	1230	2,1	600,00	NMRV-P063/150	71C/80A	4	18000
1,9	1491	1,2	750,00	NMRV-P063/130	71C/80A	4	13500
1,9	1444	1,6	750,00	NMRV-P063/150	71C/80A	4	18000
1,6	1698	1,0	900,00	NMRV-P063/130	71C/80A	4	13500
1,6	1823	1,1	900,00	NMRV-P063/150	71C/80A	4	18000
1,2	2198	1,2	1200,00	NMRV-P063/150	71C/80A	4	18000

0,75 kW

n2 [rpm]	M2 [Nm]	fs	i	Gear reducer	Motor		Fr2 [N]
					Size	Pole	
572,0	12	3,7	5,00	NMRV050	80A	2	1251
381,0	17	2,7	7,50	NMRV050	80A	2	1433
288,0	22	3,0	5,00	NMRV050	80B	4	1577
286,0	23	2,1	10,00	NMRV050	80A	2	1577
192,3	33	3,7	7,50	NMRV-P063	80B	4	2359
192,3	33	2,3	7,50	NMRV050	80B	4	1805

0,75 kW

n2 [rpm]	M2 [Nm]	fs	i	Gear reducer	Motor Size	Pole	Fr2 [N]
190,3	33	1,5	15,00	NMRV050	80A	2	1805
144,0	44	2,9	10,00	NMRV-P063	80B	4	2597
144,0	44	1,7	10,00	NMRV050	80B	4	1987
143,0	42	1,1	20,00	NMRV050	80A	2	1987
125,0	50	2,4	7,50	NMRV-P063	90S	6	2734
96,0	63	2,2	15,00	NMRV-P063	80B	4	2973
95,7	65	3,3	15,00	NMRV-P075	80B	4	3509
95,7	62	1,2	15,00	NMRV050	80B	4	2274
94,0	65	1,9	10,00	NMRV-P063	90S	6	3009
94,0	66	2,9	10,00	NMRV-P075	90S	6	3551
72,0	82	1,7	20,00	NMRV-P063	80B	4	3272
72,0	83	2,7	20,00	NMRV-P075	80B	4	3862
64,8	91	2,0	22,08	HW030+NMRV-P063	80B	4	3382
64,8	90	2,7	22,08	HW030+NMRV-P075	80B	4	3991
63,0	94	1,5	15,00	NMRV-P063	90S	6	3444
63,0	95	2,3	15,00	NMRV-P075	90S	6	4065
57,6	101	2,0	25,00	NMRV-P075	80B	4	4160
57,4	98	1,3	25,00	NMRV-P063	80B	4	3524
57,4	103	3,4	25,00	NMRV-P090	80B	4	4603
50,0	118	2,3	29,00	HW030+NMRV-P075	80B	4	4330
49,4	119	1,6	29,00	HW030+NMRV-P063	80B	4	3703
48,3	112	1,3	30,00	NMRV-P063	80B	4	3745
48,3	115	2,0	30,00	NMRV-P075	80B	4	4421
48,3	118	3,5	30,00	NMRV-P090	80B	4	4891
47,0	119	1,2	20,00	NMRV-P063	90S	6	3791
47,0	122	1,8	20,00	NMRV-P075	90S	6	4474
47,0	125	3,0	20,00	NMRV-P090	90S	6	4951
46,0	127	3,6	31,05	HW040+NMRV-P090	80B	4	4902
40,0	146	2,8	23,29	HW040+NMRV-P090	90S	6	5134
40,0	146	2,8	23,29	HW040+NMRV-P110	90S	6	6487
38,0	149	1,4	25,00	NMRV-P075	90S	6	4820
37,8	153	2,3	25,00	NMRV-P090	90S	6	5333
37,0	151	1,2	38,67	HW030+NMRV-P063	80B	4	4076
37,0	153	1,9	38,67	HW030+NMRV-P075	80B	4	4811
36,0	141	1,0	40,00	NMRV-P063	80B	4	4122
36,0	145	1,6	40,00	NMRV-P075	80B	4	4865
36,0	152	2,5	40,00	NMRV-P090	80B	4	5383
33,9	169	2,9	42,00	HW040+NMRV-P090	80B	4	5472
33,9	169	2,9	42,00	HW040+NMRV-P110	80B	4	6914
33,0	166	1,1	44,17	HW030+NMRV-P063	80B	4	4221
32,9	170	1,5	44,17	HW030+NMRV-P075	80B	4	5029
31,7	169	1,3	30,00	NMRV-P075	90S	6	5122

0,75 kW

n2 [rpm]	M2 [Nm]	fs	i	Gear reducer	Size	Motor Pole	Fr2 [N]
31,7	174	2,3	30,00	NMRV-P090	90S	6	5667
31,0	183	2,8	46,58	HW040+NMRV-P090	80B	4	5611
30,2	184	1,1	47,50	HW030+NMRV-P063	80B	4	4334
30,0	186	1,6	47,50	HW030+NMRV-P075	80B	4	5104
30,0	190	2,4	31,05	HW040+NMRV-P090	90S	6	5650
30,0	190	2,8	31,05	HW040+NMRV-P110	90S	6	7140
29,0	182	2,0	50,00	NMRV-P090	80B	4	5799
29,0	189	3,3	50,00	NMRV-P110	80B	4	7328
28,8	174	1,2	50,00	NMRV-P075	80B	4	5241
25,0	219	1,3	58,00	HW030+NMRV-P075	80B	4	5455
24,0	197	1,0	60,00	NMRV-P075	80B	4	5569
24,0	221	2,6	60,00	NMRV-P110	80B	4	7787
23,7	241	3,3	62,11	HW040+NMRV-P110	80B	4	7877
23,7	209	1,6	60,00	NMRV-P090	80B	4	6163
23,5	210	1,1	40,00	NMRV-P075	90S	6	5637
23,5	219	1,7	40,00	NMRV-P090	90S	6	6238
23,5	229	3,0	40,00	NMRV-P110	90S	6	7882
23,2	242	2,3	63,00	HW040+NMRV-P090	80B	4	6219
22,5	255	1,9	42,00	HW040+NMRV-P090	90S	6	6294
22,5	255	1,9	42,00	HW040+NMRV-P110	90S	6	7953
20,4	273	1,9	46,58	HW040+NMRV-P090	90S	6	6515
20,0	266	1,2	71,25	HW030+NMRV-P075	80B	4	5843
20,0	276	2,8	46,58	HW040+NMRV-P110	90S	6	8173
18,5	294	2,8	77,63	HW040+NMRV-P110	80B	4	8485
18,4	263	1,3	50,00	NMRV-P090	90S	6	6719
18,4	274	2,2	50,00	NMRV-P110	90S	6	8491
18,1	279	1,2	77,33	HW030+NMRV-P075	80B	4	6018
18,1	282	1,6	77,63	HW040+NMRV-P090	80B	4	6668
18,0	255	1,1	80,00	NMRV-P090	80B	4	6783
18,0	271	1,8	80,00	NMRV-P110	80B	4	8571
17,5	303	1,0	81,82	HW030+NMRV-P075	80B	4	6176
17,5	311	1,7	84,00	HW040+NMRV-P090	80B	4	6894
17,1	320	2,9	84,00	HW040+NMRV-P110	80B	4	8650
16,5	293	1,1	88,33	HW030+NMRV-P075	80B	4	6336
15,3	364	1,5	63,00	HW040+NMRV-P090	90S	6	7204
15,3	359	2,1	62,11	HW040+NMRV-P110	90S	6	9060
15,3	298	1,1	60,00	NMRV-P090	90S	6	7140
15,3	315	1,8	60,00	NMRV-P110	90S	6	9023
15,1	338	1,1	95,00	HW030+NMRV-P075	80B	4	6446
15,0	320	1,7	93,16	HW040+NMRV-P090	80B	4	7069
15,0	324	2,8	93,16	HW040+NMRV-P110	80B	4	8933
14,4	365	1,6	100,00	NMRV-P050/090	80B	4	6487

0,75 kW

n2 [rpm]	M2 [Nm]	fs	i	Gear reducer	Motor Size	Pole	Fr2 [N]
14,4	365	1,8	100,00	NMRV-P050/110	80B	4	8198
14,4	365	3,0	100,00	NMRV-P063/110	80B	4	8198
14,4	369	3,0	100,00	NMRV-P063/130	80B	4	10722
14,1	389	2,6	105,00	HWO40+NMRV-P110	80B	4	9318
14,1	319	1,4	100,00	NMRV-P110	80B	4	9232
13,1	384	1,0	109,09	HWO30+NMRV-P075	80B	4	6750
13,1	402	1,5	110,00	HWO40+NMRV-P090	80B	4	7489
12,3	438	1,9	77,63	HWO40+NMRV-P110	90S	6	9760
12,3	391	1,2	80,00	NMRV-P110	90S	6	9931
12,3	396	2,0	80,00	NMRV130	90S	6	12989
12,0	420	1,1	77,63	HWO40+NMRV-P090	90S	6	7669
11,2	480	1,9	84,00	HWO40+NMRV-P110	90S	6	10020
11,1	421	1,5	126,00	HWO40+NMRV-P090	80B	4	7836
11,0	467	1,2	84,00	HWO40+NMRV-P090	90S	6	7873
11,0	424	2,6	126,00	HWO40+NMRV-P110	80B	4	9879
10,3	503	1,9	137,50	HWO40+NMRV-P110	80B	4	10266
10,1	483	1,2	137,50	HWO40+NMRV-P090	80B	4	8068
10,0	472	1,2	93,16	HWO40+NMRV-P090	90S	6	8149
10,0	474	1,9	93,16	HWO40+NMRV-P110	90S	6	10297
9,6	521	1,3	150,00	NMRV-P050/090	80B	4	7426
9,6	527	1,8	150,00	NMRV-P050/110	80B	4	9384
9,6	527	2,3	150,00	NMRV-P063/110	80B	4	9384
9,6	521	3,0	150,00	NMRV-P063/130	80B	4	12274
9,6	526	3,7	150,00	NMRV-P063/150	80B	4	18000
9,2	457	1,5	100,00	NMRV130	90S	6	13500
9,0	541	1,2	165,00	HWO40+NMRV-P090	80B	4	8180
9,0	496	1,7	155,26	HWO40+NMRV-P110	80B	4	10320
9,0	584	1,7	105,00	HWO40+NMRV-P110	90S	6	10320
9,0	450	1,0	100,00	NMRV-P110	90S	6	10320
8,2	567	1,3	186,32	HWO40+NMRV-P110	80B	4	10320
8,2	548	1,9	168,00	HWO40+NMRV-P110	80B	4	10320
7,2	685	1,7	200,00	NMRV-P050/110	80B	4	10320
7,2	685	1,7	200,00	NMRV-P063/110	80B	4	10320
7,2	685	2,3	200,00	NMRV-P063/130	80B	4	13500
7,2	685	3,0	200,00	NMRV-P063/150	80B	4	18000
7,2	758	1,2	137,50	HWO40+NMRV-P110	90S	6	10320
7,0	627	1,8	126,00	HWO40+NMRV-P110	90S	6	10320
7,0	702	1,6	220,00	HWO40+NMRV-P110	80B	4	10320
6,1	729	1,1	155,26	HWO40+NMRV-P110	90S	6	10320
6,0	811	1,3	168,00	HWO40+NMRV-P110	90S	6	10320
6,0	738	1,1	252,00	HWO40+NMRV-P110	80B	4	10320
5,8	835	1,4	250,00	NMRV-P050/110	80B	4	10320

0,75 kW

n2 [rpm]	M2 [Nm]	fs	i	Gear reducer	Size	Motor Pole	Fr2 [N]
5,8	835	1,4	250,00	NMRV-P063/110	80B	4	10320
5,8	835	1,8	250,00	NMRV-P063/130	80B	4	13500
5,8	835	2,5	250,00	NMRV-P063/150	80B	4	18000
5,0	835	1,2	275,00	HW040+NMRV-P110	80B	4	10320
4,8	895	1,4	300,00	NMRV-P050/110	80B	4	10320
4,8	895	1,4	300,00	NMRV-P063/110	80B	4	10320
4,8	908	1,9	300,00	NMRV-P063/130	80B	4	13500
4,8	993	2,3	300,00	NMRV-P063/150	80B	4	18000
4,7	919	1,0	304,55	HW040+NMRV-P110	80B	4	10320
4,3	1045	1,0	220,00	HW040+NMRV-P110	90S	6	10320
3,6	1157	1,0	400,00	NMRV-P050/110	80B	4	10320
3,6	1157	1,0	400,00	NMRV-P063/110	80B	4	10320
3,6	1157	1,4	400,00	NMRV-P063/130	80B	4	13500
3,6	1175	2,3	400,00	NMRV-P063/150	80B	4	18000
2,9	1380	1,1	500,00	NMRV-P063/130	80B	4	13500
2,9	1380	1,7	500,00	NMRV-P063/150	80B	4	18000
2,4	1712	1,0	600,00	NMRV-P063/130	80B	4	13500
2,4	1702	1,6	600,00	NMRV-P063/150	80B	4	18000
1,9	1998	1,2	750,00	NMRV-P063/150	80B	4	18000

1,10 kW

n2 [rpm]	M2 [Nm]	fs	i	Gear reducer	Size	Motor Pole	Fr2 [N]
572,0	17	2,5	5,00	NMRV050	80B	2	1251
381,0	25	1,8	7,50	NMRV050	80B	2	1433
286,0	33	1,5	10,00	NMRV050	80B	2	1577
191,0	49	2,5	7,50	NMRV-P063	90S	4	2359
191,0	49	3,6	7,50	NMRV-P075	90S	4	2785
143,0	64	2,0	10,00	NMRV-P063	90S	4	2597
143,0	65	2,9	10,00	NMRV-P075	90S	4	3065
127,0	73	2,4	7,50	NMRV-P075	100LR	6	3227
95,0	95	2,0	10,00	NMRV-P075	100LR	6	3551
95,0	95	2,3	15,00	NMRV-P075	90S	4	3509
95,0	93	1,5	15,00	NMRV-P063	90S	4	2973
71,5	120	1,1	20,00	NMRV-P063	90S	4	3272
71,5	122	1,8	20,00	NMRV-P075	90S	4	3862
71,5	125	3,0	20,00	NMRV-P090	90S	4	4273
63,0	138	1,6	15,00	NMRV-P075	100LR	6	4065
63,0	141	2,7	15,00	NMRV-P090	100LR	6	4498
61,0	142	2,9	23,29	HW040+NMRV-P090	90S	4	4464
61,0	144	2,9	23,29	HW040+NMRV-P110	90S	4	5640
57,2	153	2,3	25,00	NMRV-P090	90S	4	4603

1,10 kW

n ₂ [rpm]	M ₂ [Nm]	f _s	i	Gear reducer	Motor		Fr ₂ [N]
					Size	Pole	
57,0	149	1,4	25,00	NMRV-P075	90S	4	4160
48,0	174	2,3	30,00	NMRV-P090	90S	4	4891
48,0	177	1,2	20,00	NMRV-P075	100LR	6	4474
48,0	170	1,4	30,00	NMRV-P075	90S	4	4421
48,0	181	2,0	20,00	NMRV-P090	100LR	6	4951
48,0	186	3,3	20,00	NMRV-P110	100LR	6	6256
46,0	187	2,5	31,05	HW040+NMRV-P090	90S	4	4913
46,0	187	2,9	31,05	HW040+NMRV-P110	90S	4	6208
38,0	221	1,6	25,00	NMRV-P090	100LR	6	5333
38,0	227	2,8	25,00	NMRV-P110	100LR	6	6739
36,0	215	1,1	40,00	NMRV-P075	90S	4	4865
35,8	223	1,6	40,00	NMRV-P090	90S	4	5383
35,8	232	2,9	40,00	NMRV-P110	90S	4	6803
33,7	250	1,9	42,00	HW040+NMRV-P090	90S	4	5472
33,7	250	1,9	42,00	HW040+NMRV-P110	90S	4	6914
32,0	252	1,6	30,00	NMRV-P090	100LR	6	5667
32,0	255	2,7	30,00	NMRV-P110	100LR	6	7161
30,6	270	1,9	46,58	HW040+NMRV-P090	90S	4	5664
30,6	273	2,9	46,58	HW040+NMRV-P110	90S	4	7157
28,6	268	1,3	50,00	NMRV-P090	90S	4	5799
28,6	279	2,2	50,00	NMRV-P110	90S	4	7328
24,0	318	1,2	40,00	NMRV-P090	100LR	6	6238
24,0	309	1,1	60,00	NMRV-P090	90S	4	6163
24,0	332	2,0	40,00	NMRV-P110	100LR	6	7882
23,5	326	1,8	60,00	NMRV-P110	90S	4	7787
23,0	356	2,2	62,11	HW040+NMRV-P110	90S	4	7822
22,5	358	1,6	63,00	HW040+NMRV-P090	90S	4	6264
19,0	398	1,6	50,00	NMRV-P110	100LR	6	8491
19,0	404	2,3	50,00	NMRV130	100LR	6	11105
18,4	417	1,0	77,63	HW040+NMRV-P090	90S	4	6715
18,4	434	1,9	77,63	HW040+NMRV-P110	90S	4	8485
18,0	400	1,2	80,00	NMRV-P110	90S	4	8571
18,0	406	2,0	80,00	NMRV130	90S	4	11210
17,0	460	1,2	84,00	HW040+NMRV-P090	90S	4	6845
17,0	472	2,0	84,00	HW040+NMRV-P110	90S	4	8650
16,0	458	1,3	60,00	NMRV-P110	100LR	6	9023
16,0	464	1,8	60,00	NMRV130	100LR	6	11801
16,0	471	2,5	60,00	NMRV150	100LR	6	16133
15,0	473	1,2	93,16	HW040+NMRV-P090	90S	4	7086
15,0	478	1,9	93,16	HW040+NMRV-P110	90S	4	8953
14,3	535	2,1	100,00	NMRV-P063/110	90S	4	8198
14,3	542	2,1	100,00	NMRV-P063/130	90S	4	10722

1,10 kW

n2 [rpm]	M2 [Nm]	fs	i	Gear reducer	Motor		Fr2 [N]
					Size	Pole	
14,0	478	1,5	100,00	NMRV130	90S	4	12076
13,3	575	1,7	105,00	HW040+NMRV-P110	90S	4	9384
13,0	594	1,0	110,00	HW040+NMRV-P090	90S	4	7489
12,0	575	1,4	80,00	NMRV130	100LR	6	12989
12,0	584	1,9	80,00	NMRV150	100LR	6	17757
11,0	626	1,8	126,00	HW040+NMRV-P110	90S	4	9902
10,2	742	1,2	137,50	HW040+NMRV-P110	90S	4	10266
10,0	663	1,1	100,00	NMRV130	100LR	6	13500
10,0	675	1,4	100,00	NMRV150	100LR	6	18000
9,5	774	1,5	150,00	NMRV-P063/110	90S	4	9384
9,5	764	2,1	150,00	NMRV-P063/130	90S	4	12274
9,5	771	2,6	150,00	NMRV-P063/150	90S	4	18000
9,2	732	1,1	155,26	HW040+NMRV-P110	90S	4	10320
9,0	810	1,3	168,00	HW040+NMRV-P110	90S	4	10320
7,2	1005	1,1	200,00	NMRV-P063/110	90S	4	10320
7,2	1005	1,6	200,00	NMRV-P063/130	90S	4	13500
7,2	1005	2,1	200,00	NMRV-P063/150	90S	4	18000
7,0	1036	1,1	220,00	HW040+NMRV-P110	90S	4	10320
5,7	1224	1,2	250,00	NMRV-P063/130	90S	4	13500
5,7	1224	1,7	250,00	NMRV-P063/150	90S	4	18000
4,8	1332	1,3	300,00	NMRV-P063/130	90S	4	13500
4,8	1456	1,6	300,00	NMRV-P063/150	90S	4	18000
3,6	1723	1,5	400,00	NMRV-P063/150	90S	4	18000
2,9	2024	1,2	500,00	NMRV-P063/150	90S	4	18000
2,4	2496	1,1	600,00	NMRV-P063/150	90S	4	18000

1,50 kW

n2 [rpm]	M2 [Nm]	fs	i	Gear reducer	Motor		Fr2 [N]
					Size	Pole	
191,0	67	1,8	7,50	NMRV-P063	90L	4	2359
191,0	67	2,6	7,50	NMRV-P075	90L	4	2785
143,0	87	1,4	10,00	NMRV-P063	90L	4	2597
143,0	88	2,1	10,00	NMRV-P075	90L	4	3065
143,0	89	3,6	10,00	NMRV-P090	90L	4	3391
125,0	101	1,7	7,50	NMRV-P075	100L	6	3227
125,0	102	3,0	7,50	NMRV-P090	100L	6	3570
95,0	126	1,1	15,00	NMRV-P063	90L	4	2973
95,0	129	1,6	15,00	NMRV-P075	90L	4	3509
95,0	131	2,9	15,00	NMRV-P090	90L	4	3882
94,0	131	1,4	10,00	NMRV-P075	100L	6	3551
94,0	133	2,4	10,00	NMRV-P090	100L	6	3929
71,5	166	1,3	20,00	NMRV-P075	90L	4	3862

1,50 kW

n2 [rpm]	M2 [Nm]	fs	i	Gear reducer	Size	Motor Pole	Fr2 [N]
71,5	170	2,1	20,00	NMRV-P090	90L	4	4273
71,5	173	3,5	20,00	NMRV-P110	90L	4	5399
63,0	190	1,1	15,00	NMRV-P075	100L	6	4065
63,0	194	1,9	15,00	NMRV-P090	100L	6	4498
61,0	194	2,1	23,29	HW040+NMRV-P090	90L	4	4464
61,0	196	2,1	23,29	HW040+NMRV-P110	90L	4	5640
57,0	208	1,7	25,00	NMRV-P090	90L	4	4603
57,0	213	3,0	25,00	NMRV-P110	90L	4	5816
48,0	238	1,7	30,00	NMRV-P090	90L	4	4891
48,0	241	2,9	30,00	NMRV-P110	90L	4	6181
47,5	250	1,5	20,00	NMRV-P090	100L	6	4951
47,5	256	2,4	20,00	NMRV-P110	100L	6	6256
46,3	255	1,8	31,05	HW040+NMRV-P090	90L	4	4924
46,3	255	2,1	31,05	HW040+NMRV-P110	90L	4	6222
38,0	305	1,2	25,00	NMRV-P090	100L	6	5333
37,4	313	2,0	25,00	NMRV-P110	100L	6	6739
36,0	305	1,2	40,00	NMRV-P090	90L	4	5383
36,0	317	2,1	40,00	NMRV-P110	90L	4	6803
34,0	340	1,4	42,00	HW040+NMRV-P090	90L	4	5433
34,0	340	1,4	42,00	HW040+NMRV-P110	90L	4	6865
31,3	347	1,2	30,00	NMRV-P090	100L	6	5667
31,3	352	1,9	30,00	NMRV-P110	100L	6	7161
30,6	373	2,0	46,58	HW040+NMRV-P110	90L	4	7157
30,2	368	1,4	46,58	HW040+NMRV-P090	90L	4	5637
29,0	381	1,6	50,00	NMRV-P110	90L	4	7328
24,0	445	1,3	60,00	NMRV-P110	90L	4	7787
23,2	457	1,4	40,00	NMRV-P110	100L	6	7882
23,2	489	1,2	63,00	HW040+NMRV-P090	90L	4	6234
23,0	485	1,6	62,11	HW040+NMRV-P110	90L	4	7822
19,2	549	1,1	50,00	NMRV-P110	100L	6	8491
19,2	556	1,7	50,00	NMRV130	100L	6	11105
18,4	591	1,4	77,63	HW040+NMRV-P110	90L	4	8485
18,4	553	1,4	80,00	NMRV130	90L	4	11210
17,1	643	1,4	84,00	HW040+NMRV-P110	90L	4	8670
16,2	640	1,3	60,00	NMRV130	100L	6	11801
16,2	649	1,8	60,00	NMRV150	100L	6	16133
15,3	652	1,4	93,16	HW040+NMRV-P110	90L	4	9017
14,3	730	1,5	100,00	NMRV-P063/110	90L	4	8198
14,3	739	1,5	100,00	NMRV-P063/130	90L	4	10722
14,1	784	1,3	105,00	HW040+NMRV-P110	90L	4	9340
14,1	651	1,1	100,00	NMRV130	90L	4	12076
12,0	792	1,0	80,00	NMRV130	100L	6	12989

1,50 kW

n2 [rpm]	M2 [Nm]	fs	i	Gear reducer	Motor		Fr2 [N]
					Size	Pole	
12,0	805	1,4	80,00	NMRV150	100L	6	17757
11,0	853	1,3	126,00	HW040+NMRV-P110	90L	4	9902
9,5	1055	1,1	150,00	NMRV-P063/110	90L	4	9384
9,5	1042	1,5	150,00	NMRV-P063/130	90L	4	12274
9,5	1052	1,9	150,00	NMRV-P063/150	90L	4	18000
9,0	930	1,0	100,00	NMRV150	100L	6	18000
7,2	1371	1,2	200,00	NMRV-P063/130	90L	4	13500
7,2	1371	1,5	200,00	NMRV-P063/150	90L	4	18000
5,7	1669	1,2	250,00	NMRV-P063/150	90L	4	18000
4,8	1985	1,2	300,00	NMRV-P063/150	90L	4	18000
3,6	2350	1,1	400,00	NMRV-P063/150	90L	4	18000

2,20 kW

n2 [rpm]	M2 [Nm]	fs	i	Gear reducer	Motor		Fr2 [N]
					Size	Pole	
191,7	98	1,8	7,50	NMRV-P075	100LA	4	2785
191,7	99	3,0	7,50	NMRV-P090	100LA	4	3081
144,0	129	1,5	10,00	NMRV-P075	100LA	4	3065
144,0	130	2,5	10,00	NMRV-P090	100LA	4	3391
128,0	144	1,2	7,50	NMRV-P075	112M	6	3227
128,0	146	2,1	7,50	NMRV-P090	112M	6	3570
96,0	191	1,7	10,00	NMRV-P090	112M	6	3929
95,7	189	1,1	15,00	NMRV-P075	100LA	4	3509
95,7	191	2,0	15,00	NMRV-P090	100LA	4	3882
72,0	249	1,5	20,00	NMRV-P090	100LA	4	4273
72,0	251	2,5	20,00	NMRV-P110	100LA	4	5399
64,0	279	1,3	15,00	NMRV-P090	112M	6	4498
57,2	303	1,2	25,00	NMRV-P090	100LA	4	4603
57,2	310	2,1	25,00	NMRV-P110	100LA	4	5816
48,5	368	1,7	20,00	NMRV-P110	112M	6	6256
48,3	351	2,0	30,00	NMRV-P110	100LA	4	6181
48,0	359	1,0	20,00	NMRV-P090	112M	6	4951
47,7	346	1,2	30,00	NMRV-P090	100LA	4	4891
38,0	449	1,4	25,00	NMRV-P110	112M	6	6739
36,5	462	1,4	40,00	NMRV-P110	100LA	4	6803
32,0	506	1,4	30,00	NMRV-P110	112M	6	7161
28,6	555	1,1	50,00	NMRV-P110	100LA	4	7328
28,6	555	1,7	50,00	NMRV130	100LA	4	9584
24,2	640	1,3	60,00	NMRV130	100LA	4	10185
24,0	657	1,0	40,00	NMRV-P110	112M	6	7882
24,0	648	1,8	60,00	NMRV150	100LA	4	13924
19,6	799	1,1	50,00	NMRV130	112M	6	11105

2,20 kW

n2 [rpm]	M2 [Nm]	fs	i	Gear reducer	Size	Motor Pole	Fr2 [N]
18,3	806	1,3	80,00	NMRV150	100LA	4	15325
17,8	805	1,0	80,00	NMRV130	100LA	4	11210
16,0	932	1,3	60,00	NMRV150	112M	6	16133
14,0	948	1,0	100,00	NMRV150	100LA	4	16508

3,00 kW

n2 [rpm]	M2 [Nm]	fs	i	Gear reducer	Size	Motor Pole	Fr2 [N]
193,0	132	1,3	7,50	NMRV-P075	112MS	4	2785
193,0	133	2,3	7,50	NMRV-P090	112MS	4	3081
145,0	174	1,1	10,00	NMRV-P075	112MS	4	3065
145,0	176	1,8	10,00	NMRV-P090	112MS	4	3391
97,0	258	1,5	15,00	NMRV-P090	112MS	4	3882
73,0	336	1,1	20,00	NMRV-P090	112MS	4	4273
73,0	340	1,8	20,00	NMRV-P110	112MS	4	5399
58,0	420	1,5	25,00	NMRV-P110	112MS	4	5816
49,0	496	1,2	20,00	NMRV-P110	132S	6	6256
48,0	474	1,5	30,00	NMRV-P110	112MS	4	6181
38,4	606	1,1	25,00	NMRV-P110	132S	6	6739
36,0	624	1,1	40,00	NMRV-P110	112MS	4	6803
32,0	682	1,0	30,00	NMRV-P110	132S	6	7161
29,0	751	1,2	50,00	NMRV130	112MS	4	9584
24,0	877	1,4	60,00	NMRV150	112MS	4	13924
18,0	1091	1,0	80,00	NMRV150	112MS	4	15325

4,00 kW

n2 [rpm]	M2 [Nm]	fs	i	Gear reducer	Size	Motor Pole	Fr2 [N]
193,0	176	1,0	7,50	NMRV-P075	112M	4	2785
193,0	178	1,7	7,50	NMRV-P090	112M	4	3081
145,0	234	1,4	10,00	NMRV-P090	112M	4	3391
97,0	344	1,1	15,00	NMRV-P090	112M	4	3882
73,0	453	1,4	20,00	NMRV-P110	112M	4	5399
58,4	560	1,1	25,00	NMRV-P110	112M	4	5816
48,3	633	1,1	30,00	NMRV-P110	112M	4	6181
24,0	1170	1,0	60,00	NMRV150	112M	4	13924

NRV030

Mn ₂ [Nm]	i	Pn ₁ [kW]	n ₂ [rpm]	Fr1 [N]	Fr2 [N]
12	5,00	0,76	560,0	115	474
12	7,50	0,52	373,0	125	542
12	10,00	0,40	280,0	140	597
12	15,00	0,28	187,0	140	683
11	20,00	0,21	140,0	146	752
14	25,00	0,22	112,0	210	810
14	30,00	0,19	93,0	210	861
13	40,00	0,14	70,0	127	948
12	50,00	0,11	56,0	128	1021
11	60,00	0,09	47,0	126	1085
9	80,00	0,06	35,0	130	1194

NRV040

Mn ₂ [Nm]	i	Pn ₁ [kW]	n ₂ [rpm]	Fr1 [N]	Fr2 [N]
21	5,00	1,40	560,0	200	912
25	7,50	1,10	373,0	233	1044
27	10,00	0,90	280,0	272	1149
27	15,00	0,62	187,0	291	1315
27	20,00	0,47	140,0	204	1447
25	25,00	0,36	112,0	236	1559
31	30,00	0,39	93,0	350	1657
30	40,00	0,30	70,0	350	1824
27	50,00	0,23	56,0	350	1964
26	60,00	0,19	47,0	350	2087
23	80,00	0,14	35,0	350	2298
21	100,00	0,11	28,0	350	2475

NRV050

Mn ₂ [Nm]	i	Pn ₁ [kW]	n ₂ [rpm]	Fr1 [N]	Fr2 [N]
42	5,00	2,70	560,0	280	1251
46	7,50	2,00	373,0	324	1433
49	10,00	1,60	280,0	378	1577
48	15,00	1,10	187,0	399	1805
48	20,00	0,85	140,0	417	1987
44	25,00	0,64	112,0	482	2140
55	30,00	0,70	93,0	490	2274
52	40,00	0,52	70,0	490	2503
50	50,00	0,42	56,0	490	2696
48	60,00	0,35	47,0	490	2865

NRV050

Mn_2 [Nm]	i	Pn_1 [kW]	n_2 [rpm]	Fr_1 [N]	Fr_2 [N]
44	80,00	0,26	35,0	490	3153
37	100,00	0,19	28,0	490	3397

NRV030/040

Mn ₂ [Nm]	i	Pn ₁ [kW]	n ₂ [rpm]	Fr1 [N]	Fr2 [N]
71	100,00	31,44	28,0	140	2769
72	150,00	0,22	18,7	140	3169
65	200,00	0,16	14,0	140	3488
61	250,00	0,13	11,2	140	3490
73	300,00	42,18	9,3	140	3490
65	400,00	0,10	7,0	140	3490
61	500,00	0,07	5,6	146	3490
73	600,00	0,08	4,7	146	3490
73	750,00	0,06	3,7	210	3490
73	900,00	0,06	3,1	210	3490
73	1200,00	0,04	2,3	127	3490
73	1500,00	57,58	1,9	128	3490
73	1800,00	0,03	1,6	126	3490
65	2400,00	60,95	1,2	126	3490
60	3000,00	0,02	0,9	126	3490
48	4000,00	0,01	0,7	128	3490
43	5000,00	0,01	0,6	128	3490

NRV030/050

Mn ₂ [Nm]	i	Pn ₁ [kW]	n ₂ [rpm]	Fr1 [N]	Fr2 [N]
93	100,00	0,40	28,0	140	3800
128	150,00	0,40	18,7	140	4350
120	200,00	59,29	14,0	140	4788
110	250,00	0,23	11,2	140	4840
145	300,00	82,39	9,3	140	4840
124	400,00	78,29	7,0	140	4840
120	500,00	0,16	5,6	140	4840
145	600,00	89,69	4,7	146	4840
145	750,00	94,47	3,7	210	4840
145	900,00	0,11	3,1	210	4840
145	1200,00	105,75	2,3	127	4840
145	1500,00	0,07	1,9	128	4840
145	1800,00	0,07	1,6	126	4840
124	2400,00	114,11	1,2	126	4840
120	3000,00	0,04	0,9	126	4840
82	4000,00	0,02	0,7	128	4840
79	5000,00	102,13	0,6	128	4840

NRV-P030/063

Mn_2 [Nm]	i	Pn_1 [kW]	n_2 [rpm]	Fr_1 [N]	Fr_2 [N]
93	100,00	0,40	28,0	140	4967
130	150,00	0,40	18,7	140	5686
164	200,00	0,40	14,0	140	6259
197	250,00	0,40	11,2	140	6270
255	300,00	153,46	9,3	125	6270
255	400,00	155,24	7,0	140	6270
236	500,00	0,31	5,6	140	6270
207	600,00	0,21	4,7	146	6270
257	750,00	0,22	3,7	210	6270
256	900,00	0,19	3,1	210	6270
234	1200,00	0,14	2,3	127	6270
216	1500,00	0,11	1,9	128	6270
199	1800,00	0,09	1,6	126	6270
243	2400,00	0,09	1,2	126	6270
236	3000,00	0,08	0,9	126	6270
226	4000,00	0,06	0,7	130	6270
150	5000,00	188,67	0,6	128	6270

NRV040/050

Mn_2 [Nm]	i	Pn_1 [kW]	n_2 [rpm]	Fr_1 [N]	Fr_2 [N]
137	100,00	0,58	28,0	272	3800
135	150,00	0,41	18,7	272	4350
120	200,00	0,29	14,0	272	4788
110	250,00	0,23	11,2	272	4840
145	300,00	80,52	9,3	272	4840
124	400,00	0,19	7,0	272	4840
137	500,00	0,15	5,6	350	3800
145	600,00	85,37	4,7	204	4840
145	750,00	88,57	3,7	236	4840
135	900,00	0,09	3,1	350	4350
145	1200,00	97,06	2,3	350	4840
145	1500,00	102,69	1,9	350	4840
145	1800,00	0,06	1,6	350	4840
124	2400,00	102,01	1,2	350	4840
120	3000,00	0,04	0,9	350	4840
120	4000,00	0,03	0,7	350	4840
120	5000,00	127,94	0,6	350	4840

NRV-P040/063

Mn_2 [Nm]	i	Pn_1 [kW]	n2 [rpm]	Fr1 [N]	Fr2 [N]
213	100,00	0,90	28,0	272	4967
260	150,00	0,78	18,7	272	5686
253	200,00	0,60	14,0	272	6259
231	250,00	0,46	11,2	272	6270
271	300,00	0,49	9,3	272	6270
255	400,00	151,71	7,0	272	6270
231	500,00	0,24	5,6	204	6270
271	600,00	0,26	4,7	204	6270
271	750,00	0,22	3,7	236	6270
271	900,00	0,19	3,1	350	6270
271	1200,00	0,15	2,3	350	6270
271	1500,00	0,13	1,9	350	6270
271	1800,00	0,11	1,6	350	6270
255	2400,00	202,28	1,2	350	6270
236	3000,00	0,07	0,9	350	6270
236	4000,00	221,77	0,7	350	6270
236	5000,00	241,94	0,6	350	6270

NRV-P040/075

Mn_2 [Nm]	i	Pn_1 [kW]	n2 [rpm]	Fr1 [N]	Fr2 [N]
216	100,00	0,90	28,0	272	5863
308	150,00	0,90	18,7	272	6712
389	200,00	0,90	14,0	272	7380
380	250,00	0,73	11,2	272	7380
444	300,00	0,77	9,3	272	7380
414	400,00	0,58	7,0	272	7380
368	500,00	0,45	5,6	272	7380
444	600,00	0,41	4,7	204	7380
444	750,00	0,34	3,7	236	7380
444	900,00	0,29	3,1	350	7380
444	1200,00	0,23	2,3	350	7380
444	1500,00	0,20	1,9	350	7380
444	1800,00	0,17	1,6	350	7380
414	2400,00	311,72	1,2	350	7380
368	3000,00	0,10	0,9	350	7380
368	4000,00	0,08	0,7	350	7380
368	5000,00	363,28	0,6	350	7380

NRV-P040/090

Mn_2 [Nm]	i	Pn_1 [kW]	n2 [rpm]	Fr1 [N]	Fr2 [N]
222	100,00	0,90	28,0	272	6487
316	150,00	0,90	18,7	272	7426
405	200,00	0,90	14,0	272	8174
486	250,00	0,90	11,2	272	8180
543	300,00	0,90	9,3	272	8180
610	400,00	0,82	7,0	272	8180
560	500,00	0,64	5,6	272	8180
535	600,00	0,47	4,7	204	8180
494	750,00	0,36	3,7	236	8180
618	900,00	0,39	3,1	350	8180
601	1200,00	0,30	2,3	350	8180
544	1500,00	0,23	1,9	350	8180
516	1800,00	0,19	1,6	350	8180
610	2400,00	437,07	1,2	350	8180
560	3000,00	0,14	0,9	350	8180
560	4000,00	0,12	0,7	350	8180
560	5000,00	0,10	0,6	350	8180

NRV-P050/090

Mn_2 [Nm]	i	Pn_1 [kW]	n2 [rpm]	Fr1 [N]	Fr2 [N]
398	100,00	1,60	28,0	378	6487
568	150,00	1,60	18,7	378	7426
610	200,00	1,34	14,0	378	8174
570	250,00	1,04	11,2	378	8180
700	300,00	1,15	9,3	378	8180
610	400,00	0,81	7,0	378	8180
570	500,00	0,56	5,6	417	8180
700	600,00	0,62	4,7	417	8180
700	750,00	378,18	3,7	482	8180
700	900,00	0,44	3,1	490	8180
700	1200,00	0,34	2,3	490	8180
700	1500,00	437,60	1,9	490	8180
700	1800,00	0,25	1,6	490	8180
610	2400,00	430,54	1,2	490	8180
560	3000,00	0,14	0,9	490	8180
560	4000,00	0,11	0,7	490	8180
560	5000,00	0,10	0,6	490	8180

NRV-P050/110

Mn_2 [Nm]	i	Pn_1 [kW]	n_2 [rpm]	Fr_1 [N]	Fr_2 [N]
398	100,00	1,60	28,0	378	8198
576	150,00	1,60	18,7	378	9384
748	200,00	1,60	14,0	378	10320
911	250,00	1,60	11,2	378	10320
976	300,00	1,60	9,3	378	10320
1185	400,00	1,50	7,0	378	10320
902	500,00	0,85	5,6	417	10320
967	600,00	0,85	4,7	417	10320
888	750,00	0,64	3,7	482	10320
1109	900,00	0,70	3,1	490	10320
1055	1200,00	0,52	2,3	490	10320
1008	1500,00	0,42	1,9	490	10320
965	1800,00	0,35	1,6	490	10320
1185	2400,00	0,33	1,2	490	10320
1100	3000,00	0,26	0,9	490	10320
1100	4000,00	0,21	0,7	490	10320
1100	5000,00	912,60	0,6	490	10320

NRV030

Mn ₂ [Nm]	i	Pn ₁ [kW]	n ₂ [rpm]	Fr1 [N]	Fr2 [N]
18	5,00	0,76	350,0	150	554
18	7,50	0,52	233,0	150	634
18	10,00	0,40	175,0	169	698
18	15,00	0,28	117,0	169	799
17	20,00	0,21	88,0	179	880
21	25,00	0,22	70,0	210	948
20	30,00	0,19	58,0	210	1007
18	40,00	0,14	44,0	210	1108
17	50,00	0,11	35,0	210	1194
15	60,00	0,09	29,0	210	1269
12	80,00	0,06	22,0	210	1396

NRV040

Mn ₂ [Nm]	i	Pn ₁ [kW]	n ₂ [rpm]	Fr1 [N]	Fr2 [N]
34	5,00	1,40	350,0	250	1066
39	7,50	1,10	233,0	291	1221
42	10,00	0,90	175,0	343	1344
42	15,00	0,62	117,0	343	1538
41	20,00	0,47	88,0	350	1693
37	25,00	0,36	70,0	350	1824
45	30,00	0,39	58,0	350	1938
43	40,00	0,30	44,0	350	2133
40	50,00	0,23	35,0	350	2298
36	60,00	0,19	29,0	350	2442
31	80,00	0,13	22,0	350	2687
28	100,00	0,11	18,0	350	2895

NRV050

Mn ₂ [Nm]	i	Pn ₁ [kW]	n ₂ [rpm]	Fr1 [N]	Fr2 [N]
65	5,00	2,68	350,0	350	1464
72	7,50	2,00	233,0	396	1676
75	10,00	1,58	175,0	490	1844
75	15,00	1,10	117,0	490	2111
74	20,00	0,85	88,0	490	2324
67	25,00	0,64	70,0	490	2503
84	30,00	0,70	58,0	490	2660
77	40,00	0,52	44,0	490	2927
73	50,00	0,42	35,0	490	3153
68	60,00	0,35	29,0	490	3351

NRV050

Mn_2 [Nm]	i	Pn_1 [kW]	n2 [rpm]	Fr1 [N]	Fr2 [N]
61	80,00	0,26	22,0	490	3688
52	100,00	0,19	18,0	490	3973

NRV-P063

Mn_2 [Nm]	i	Pn_1 [kW]	n2 [rpm]	Fr1 [N]	Fr2 [N]
121	7,50	3,30	233,0	500	2190
124	10,00	2,60	175,0	579	2411
139	15,00	2,00	117,0	646	2759
135	20,00	1,50	88,0	700	3037
127	25,00	1,17	70,0	700	3272
149	30,00	1,20	58,0	700	3477
142	40,00	0,90	44,0	700	3827
136	50,00	0,73	35,0	700	4122
128	60,00	0,61	29,0	700	4380
116	80,00	0,45	22,0	700	4821
111	100,00	0,38	18,0	700	5193

NRV-P075

Mn_2 [Nm]	i	Pn_1 [kW]	n2 [rpm]	Fr1 [N]	Fr2 [N]
176	7,50	4,80	233,0	700	2585
187	10,00	3,88	175,0	839	2845
212	15,00	3,00	117,0	962	3257
219	20,00	2,40	88,0	980	3585
200	25,00	1,80	70,0	980	3862
230	30,00	1,80	58,0	980	4104
226	40,00	1,40	44,0	980	4517
212	50,00	1,09	35,0	980	4865
201	60,00	0,91	29,0	980	5170
184	80,00	0,68	22,0	980	5691
171	100,00	0,55	18,0	980	6130

NRV-P090

Mn_2 [Nm]	i	Pn_1 [kW]	n2 [rpm]	Fr1 [N]	Fr2 [N]
303	7,50	8,19	233,0	900	2860
324	10,00	6,65	175,0	1082	3148
376	15,00	5,25	117,0	1257	3604
370	20,00	3,96	88,0	1270	3967

NRV-P090

Mn_2 [Nm]	i	Pn_1 [kW]	n_2 [rpm]	Fr_1 [N]	Fr_2 [N]
354	25,00	3,10	70,0	1270	4273
405	30,00	3,10	58,0	1270	4541
369	40,00	2,20	44,0	1270	4998
355	50,00	1,76	35,0	1270	5383
326	60,00	1,40	29,0	1270	5721
271	80,00	0,95	22,0	1270	6297
257	100,00	0,77	18,0	1270	6783

NRV-P110

Mn_2 [Nm]	i	Pn_1 [kW]	n_2 [rpm]	Fr_1 [N]	Fr_2 [N]
612	20,00	6,47	88,0	1700	5012
643	25,00	5,50	70,0	1700	5399
688	30,00	5,20	58,0	1700	5737
662	40,00	3,80	44,0	1700	6315
627	50,00	2,99	35,0	1700	6803
585	60,00	2,39	29,0	1700	7229
484	80,00	1,60	22,0	1700	7956
459	100,00	1,29	18,0	1700	8571

NRV130

Mn_2 [Nm]	i	Pn_1 [kW]	n_2 [rpm]	Fr_1 [N]	Fr_2 [N]
930	50,00	4,48	35,0	2100	8897
855	60,00	3,58	29,0	2100	9455
783	80,00	2,60	22,0	2100	10406
703	100,00	1,98	18,0	2100	11210

NRV150

Mn_2 [Nm]	i	Pn_1 [kW]	n_2 [rpm]	Fr_1 [N]	Fr_2 [N]
1187	60,00	4,90	29,0	2800	12926
1084	80,00	3,60	22,0	2800	14226
950	100,00	2,68	18,0	2800	15325

NRV030/040

Mn ₂ [Nm]	i	Pn ₁ [kW]	n ₂ [rpm]	Fr1 [N]	Fr2 [N]
71	100,00	0,20	17,5	169	2769
72	150,00	0,15	11,7	169	3169
65	200,00	0,10	8,8	169	3488
61	250,00	0,08	7,0	169	3490
73	300,00	0,09	5,8	169	3490
65	400,00	0,07	4,4	169	3490
61	500,00	0,05	3,5	179	3490
73	600,00	0,05	2,9	179	3490
73	750,00	0,04	2,3	210	3490
73	900,00	0,04	1,9	210	3490
73	1200,00	0,03	1,5	210	3490
73	1500,00	0,03	1,2	210	3490
73	1800,00	43,60	1,0	210	3490
65	2400,00	0,02	0,7	210	3490
60	3000,00	0,01	0,6	210	3490
48	4000,00	0,01	0,4	210	3490
43	5000,00	0,01	0,4	210	3490

NRV030/050

Mn ₂ [Nm]	i	Pn ₁ [kW]	n ₂ [rpm]	Fr1 [N]	Fr2 [N]
137	100,00	0,38	17,5	169	3800
135	150,00	40,83	11,7	169	4350
120	200,00	38,40	8,8	169	4788
110	250,00	37,36	7,0	169	4840
145	300,00	0,18	5,8	169	4840
124	400,00	0,13	4,4	169	4840
120	500,00	52,99	3,5	169	4840
145	600,00	0,10	2,9	179	4840
145	750,00	64,18	2,3	210	4840
145	900,00	0,07	1,9	210	4840
145	1200,00	0,06	1,5	210	4840
145	1500,00	79,08	1,2	210	4840
145	1800,00	85,16	1,0	210	4840
124	2400,00	0,03	0,7	210	4840
120	3000,00	0,03	0,6	210	4840
82	4000,00	0,02	0,4	210	4840
79	5000,00	71,81	0,4	210	4840

NRV-P030/063

Mn ₂ [Nm]	i	Pn ₁ [kW]	n ₂ [rpm]	Fr1 [N]	Fr2 [N]
143	100,00	0,40	17,5	169	4967
201	150,00	0,40	11,7	169	5686
253	200,00	0,40	8,8	169	6259
231	250,00	0,30	7,0	169	6270
255	300,00	98,17	5,8	150	6270
255	400,00	100,53	4,4	169	6270
236	500,00	0,20	3,5	169	6270
271	600,00	0,18	2,9	179	6270
271	750,00	0,16	2,3	210	6270
271	900,00	0,14	1,9	210	6270
271	1200,00	0,11	1,5	210	6270
271	1500,00	0,10	1,2	210	6270
271	1800,00	0,09	1,0	210	6270
255	2400,00	160,47	0,7	210	6270
236	3000,00	159,93	0,6	210	6270
236	4000,00	184,81	0,4	210	6270
150	5000,00	0,03	0,4	210	6270

NRV040/050

Mn ₂ [Nm]	i	Pn ₁ [kW]	n ₂ [rpm]	Fr1 [N]	Fr2 [N]
137	100,00	37,39	17,5	343	3800
135	150,00	0,27	11,7	343	4350
120	200,00	0,19	8,8	343	4788
110	250,00	0,15	7,0	343	4840
145	300,00	0,17	5,8	343	4840
124	400,00	0,12	4,4	343	4840
137	500,00	0,10	3,5	350	3800
145	600,00	0,09	2,9	350	4840
145	750,00	58,27	2,3	350	4840
135	900,00	57,44	1,9	350	4350
145	1200,00	0,06	1,5	350	4840
145	1500,00	70,29	1,2	350	4840
145	1800,00	0,04	1,0	350	4840
124	2400,00	0,03	0,7	350	4840
120	3000,00	0,03	0,6	350	4840
120	4000,00	0,02	0,4	350	4840
120	5000,00	0,02	0,4	350	4840

NRV-P040/063

Mn_2 [Nm]	i	Pn_1 [kW]	n_2 [rpm]	Fr_1 [N]	Fr_2 [N]
257	100,00	70,13	17,5	343	4967
260	150,00	0,50	11,7	343	5686
253	200,00	0,39	8,8	343	6259
231	250,00	0,30	7,0	343	6270
271	300,00	0,32	5,8	343	6270
255	400,00	98,17	4,4	343	6270
231	500,00	0,16	3,5	350	6270
271	600,00	0,17	2,9	350	6270
271	750,00	0,14	2,3	350	6270
271	900,00	0,13	1,9	350	6270
271	1200,00	0,10	1,5	350	6270
271	1500,00	0,09	1,2	350	6270
271	1800,00	0,08	1,0	350	6270
255	2400,00	141,43	0,7	350	6270
236	3000,00	140,96	0,6	350	6270
236	4000,00	156,92	0,4	350	6270
236	5000,00	0,04	0,4	350	6270

NRV-P040/075

Mn_2 [Nm]	i	Pn_1 [kW]	n_2 [rpm]	Fr_1 [N]	Fr_2 [N]
334	100,00	0,90	17,5	343	5863
425	150,00	0,80	11,7	343	6712
420	200,00	0,63	8,8	343	7380
380	250,00	0,47	7,0	343	7380
444	300,00	0,50	5,8	343	7380
414	400,00	151,27	4,4	343	7380
368	500,00	0,29	3,5	343	7380
444	600,00	0,27	2,9	350	7380
444	750,00	0,22	2,3	350	7380
444	900,00	0,20	1,9	350	7380
444	1200,00	0,16	1,5	350	7380
444	1500,00	0,13	1,2	350	7380
444	1800,00	0,12	1,0	350	7380
414	2400,00	217,94	0,7	350	7380
368	3000,00	0,07	0,6	350	7380
368	4000,00	0,06	0,4	350	7380
368	5000,00	0,05	0,4	350	7380

NRV-P040/090

Mn ₂ [Nm]	i	Pn ₁ [kW]	n ₂ [rpm]	Fr1 [N]	Fr2 [N]
342	100,00	0,90	17,5	343	6487
488	150,00	0,90	11,7	343	7426
610	200,00	0,88	8,8	343	8174
570	250,00	0,68	7,0	343	8180
700	300,00	0,75	5,8	343	8180
610	400,00	212,11	4,4	343	8180
560	500,00	0,42	3,5	343	8180
700	600,00	0,40	2,9	350	8180
700	750,00	0,34	2,3	350	8180
700	900,00	0,30	1,9	350	8180
700	1200,00	0,24	1,5	350	8180
700	1500,00	0,20	1,2	350	8180
700	1800,00	0,18	1,0	350	8180
610	2400,00	0,13	0,7	350	8180
560	3000,00	0,10	0,6	350	8180
560	4000,00	0,08	0,4	350	8180
560	5000,00	368,60	0,4	350	8180

NRV-P050/090

Mn ₂ [Nm]	i	Pn ₁ [kW]	n ₂ [rpm]	Fr1 [N]	Fr2 [N]
590	100,00	1,52	17,5	490	6487
660	150,00	1,19	11,7	490	7426
610	200,00	0,86	8,8	490	8174
570	250,00	0,67	7,0	490	8180
700	300,00	0,73	5,8	490	8180
610	400,00	0,52	4,4	490	8180
570	500,00	0,36	3,5	490	8180
700	600,00	0,40	2,9	490	8180
700	750,00	0,33	2,3	490	8180
700	900,00	0,29	1,9	490	8180
700	1200,00	0,23	1,5	490	8180
700	1500,00	0,20	1,2	490	8180
700	1800,00	0,18	1,0	490	8180
610	2400,00	0,13	0,7	490	8180
560	3000,00	0,10	0,6	490	8180
560	4000,00	0,08	0,4	490	8180
560	5000,00	0,07	0,4	490	8180

NRV-P050/110

Mn ₂ [Nm]	i	Pn ₁ [kW]	n ₂ [rpm]	Fr1 [N]	Fr2 [N]
615	100,00	1,58	17,5	490	8198
889	150,00	1,58	11,7	490	9384
1139	200,00	1,56	8,8	490	10320
1173	250,00	1,32	7,0	490	10320
1265	300,00	1,33	5,8	490	10320
1185	400,00	0,96	4,4	490	10320
1173	500,00	0,72	3,5	490	10320
1265	600,00	0,72	2,9	490	10320
1265	750,00	449,32	2,3	490	10320
1265	900,00	0,53	1,9	490	10320
1265	1200,00	0,42	1,5	490	10320
1265	1500,00	0,36	1,2	490	10320
1265	1800,00	0,32	1,0	490	10320
1185	2400,00	0,23	0,7	490	10320
1100	3000,00	541,86	0,6	490	10320
1100	4000,00	0,15	0,4	490	10320
1100	5000,00	0,13	0,4	490	10320

NRV-P063/110

Mn ₂ [Nm]	i	Pn ₁ [kW]	n ₂ [rpm]	Fr1 [N]	Fr2 [N]
1017	100,00	2,60	17,5	579	8198
1196	150,00	2,12	11,7	579	9384
1139	200,00	1,55	8,8	579	10320
1173	250,00	1,31	7,0	579	10320
1265	300,00	1,32	5,8	579	10320
1185	400,00	0,96	4,4	579	10320
1173	500,00	0,69	3,5	700	10320
1265	600,00	0,70	2,9	700	10320
1265	750,00	433,25	2,3	700	10320
1265	900,00	0,51	1,9	700	10320
1265	1200,00	0,40	1,5	700	10320
1265	1500,00	0,34	1,2	700	10320
1265	1800,00	0,30	1,0	700	10320
1185	2400,00	519,67	0,7	700	10320
1100	3000,00	0,17	0,6	700	10320
1100	4000,00	0,14	0,4	700	10320
1100	5000,00	0,12	0,4	700	10320

NRV-P063/130

Mn ₂ [Nm]	i	Pn ₁ [kW]	n ₂ [rpm]	Fr1 [N]	Fr2 [N]
1030	100,00	2,60	17,5	579	10722
1451	150,00	2,60	11,7	579	12274
1600	200,00	2,18	8,8	579	13500
1530	250,00	1,71	7,0	579	13500
1760	300,00	1,81	5,8	579	13500
1650	400,00	1,33	4,4	579	13500
1550	500,00	1,05	3,5	579	13500
1760	600,00	0,96	2,9	700	13500
1760	750,00	0,79	2,3	700	13500
1760	900,00	0,69	1,9	700	13500
1760	1200,00	0,55	1,5	700	13500
1760	1500,00	696,74	1,2	700	13500
1760	1800,00	737,78	1,0	700	13500
1650	2400,00	0,30	0,7	700	13500
1550	3000,00	712,62	0,6	700	13500
1550	4000,00	0,19	0,4	700	13500
1550	5000,00	856,29	0,4	700	13500

NRV-P063/150

Mn ₂ [Nm]	i	Pn ₁ [kW]	n ₂ [rpm]	Fr1 [N]	Fr2 [N]
1860	150,00	3,30	11,7	500	18000
1910	200,00	2,60	8,8	579	18000
2050	250,00	572,89	7,0	579	18000
2134	300,00	2,00	5,8	646	18000
2670	400,00	2,12	4,4	579	18000
2330	500,00	1,58	3,5	579	18000
2670	600,00	1,46	2,9	646	18000
2330	750,00	1,08	2,3	646	18000
2100	900,00	0,77	1,9	700	18000
2670	1200,00	977,25	1,5	700	18000
2330	1500,00	907,83	1,2	700	18000
2100	1800,00	0,46	1,0	700	18000
2670	2400,00	0,48	0,7	700	18000
2330	3000,00	1071,23	0,6	700	18000
2330	4000,00	0,29	0,4	700	18000
2330	5000,00	0,26	0,4	700	18000

NRV030

Mn_2 [Nm]	i	Pn_1 [kW]	n_2 [rpm]	Fr_1 [N]	Fr_2 [N]
18	5,00	0,61	280,0	150	597
18	7,50	0,41	187,0	150	683
18	10,00	0,32	140,0	169	752
18	15,00	0,23	93,0	169	861
17	20,00	0,17	70,0	180	948
21	25,00	0,18	56,0	210	1021
20	30,00	0,15	47,0	210	1085
18	40,00	0,11	35,0	210	1194
17	50,00	0,09	28,0	210	1286
15	60,00	0,07	23,0	210	1367
12	80,00	0,05	18,0	210	1504

NRV040

Mn_2 [Nm]	i	Pn_1 [kW]	n_2 [rpm]	Fr_1 [N]	Fr_2 [N]
34	5,00	1,12	280,0	250	1149
40	7,50	0,90	187,0	292	1315
42	10,00	0,72	140,0	344	1447
42	15,00	0,49	93,0	344	1657
41	20,00	0,38	70,0	350	1824
37	25,00	0,29	56,0	350	1964
46	30,00	0,32	47,0	350	2087
43	40,00	0,24	35,0	350	2298
40	50,00	0,19	28,0	350	2475
36	60,00	0,15	23,0	350	2630
31	80,00	0,11	18,0	350	2895
28	100,00	0,09	14,0	350	3118

NRV050

Mn_2 [Nm]	i	Pn_1 [kW]	n_2 [rpm]	Fr_1 [N]	Fr_2 [N]
65	5,00	2,14	280,0	350	1577
73	7,50	1,62	187,0	396	1805
75	10,00	1,26	140,0	490	1987
77	15,00	0,91	93,0	490	2274
74	20,00	0,68	70,0	490	2503
67	25,00	0,51	56,0	490	2696
84	30,00	0,56	47,0	490	2865
78	40,00	0,42	35,0	490	3153
73	50,00	0,33	28,0	490	3397
68	60,00	0,28	23,0	490	3610

NRV050

Mn_2 [Nm]	i	Pn_1 [kW]	n2 [rpm]	Fr1 [N]	Fr2 [N]
62	80,00	0,21	18,0	490	3973
52	100,00	0,15	14,0	490	4280

NRV-P063

Mn_2 [Nm]	i	Pn_1 [kW]	n2 [rpm]	Fr1 [N]	Fr2 [N]
122	7,50	2,68	187,0	500	2359
125	10,00	2,11	140,0	595	2597
140	15,00	1,63	93,0	660	2973
138	20,00	1,23	70,0	700	3272
127	25,00	0,94	56,0	700	3524
152	30,00	0,99	47,0	700	3745
142	40,00	0,73	35,0	700	4122
136	50,00	0,60	28,0	700	4440
128	60,00	0,50	23,0	700	4719
116	80,00	0,37	18,0	700	5193
112	100,00	0,32	14,0	700	5595

NRV-P075

Mn_2 [Nm]	i	Pn_1 [kW]	n2 [rpm]	Fr1 [N]	Fr2 [N]
176	7,50	3,87	187,0	700	2785
187	10,00	3,12	140,0	857	3065
215	15,00	2,44	93,0	979	3509
220	20,00	1,94	70,0	980	3862
202	25,00	1,46	56,0	980	4160
230	30,00	1,46	47,0	980	4421
230	40,00	1,15	35,0	980	4865
212	50,00	0,89	28,0	980	5241
200	60,00	0,74	23,0	980	5569
184	80,00	0,55	18,0	980	6130
171	100,00	0,45	14,0	980	6603

NRV-P090

Mn_2 [Nm]	i	Pn_1 [kW]	n2 [rpm]	Fr1 [N]	Fr2 [N]
303	7,50	6,58	187,0	900	3081
324	10,00	5,34	140,0	1082	3391
376	15,00	4,22	93,0	1257	3882
370	20,00	3,19	70,0	1270	4273

NRV-P090

Mn ₂ [Nm]	i	Pn ₁ [kW]	n ₂ [rpm]	Fr1 [N]	Fr2 [N]
355	25,00	2,51	56,0	1270	4603
410	30,00	2,54	47,0	1270	4891
376	40,00	1,81	35,0	1270	5383
355	50,00	1,43	28,0	1270	5799
334	60,00	1,17	23,0	1270	6163
271	80,00	0,78	18,0	1270	6783
257	100,00	0,63	14,0	1270	7306

NRV-P110

Mn ₂ [Nm]	i	Pn ₁ [kW]	n ₂ [rpm]	Fr1 [N]	Fr2 [N]
612	20,00	5,22	70,0	1700	5399
645	25,00	4,45	56,0	1700	5816
690	30,00	4,21	47,0	1700	6181
667	40,00	3,09	35,0	1700	6803
627	50,00	2,42	28,0	1700	7328
585	60,00	1,93	23,0	1700	7787
490	80,00	1,32	18,0	1700	8571
459	100,00	1,05	14,0	1700	9232

NRV130

Mn ₂ [Nm]	i	Pn ₁ [kW]	n ₂ [rpm]	Fr1 [N]	Fr2 [N]
930	50,00	3,59	28,0	2100	9584
855	60,00	2,86	23,0	2100	10185
798	80,00	2,12	18,0	2100	11210
703	100,00	1,59	14,0	2100	12076

NRV150

Mn ₂ [Nm]	i	Pn ₁ [kW]	n ₂ [rpm]	Fr1 [N]	Fr2 [N]
1197	60,00	3,95	23,0	2800	13924
1093	80,00	2,90	18,0	2800	15325
950	100,00	2,14	14,0	2800	16508

NRV030/040

Mn ₂ [Nm]	i	Pn ₁ [kW]	n ₂ [rpm]	Fr1 [N]	Fr2 [N]
71	100,00	0,16	14,0	169	2769
72	150,00	0,12	9,3	169	3169
65	200,00	0,08	7,0	169	3488
61	250,00	0,07	5,6	169	3490
73	300,00	0,07	4,7	169	3490
65	400,00	0,05	3,5	169	3490
61	500,00	0,04	2,8	180	3490
73	600,00	0,04	2,3	180	3490
73	750,00	0,04	1,9	210	3490
73	900,00	0,03	1,6	210	3490
73	1200,00	0,03	1,2	210	3490
73	1500,00	32,39	0,9	210	3490
73	1800,00	0,02	0,8	210	3490
65	2400,00	34,57	0,6	210	3490
60	3000,00	0,01	0,5	210	3490
48	4000,00	0,01	0,4	210	3490
43	5000,00	32,16	0,3	210	3490

NRV030/050

Mn ₂ [Nm]	i	Pn ₁ [kW]	n ₂ [rpm]	Fr1 [N]	Fr2 [N]
137	100,00	0,31	14,0	169	3800
135	150,00	32,66	9,3	169	4350
120	200,00	30,72	7,0	169	4788
110	250,00	0,12	5,6	169	4840
145	300,00	42,68	4,7	169	4840
124	400,00	0,10	3,5	169	4840
120	500,00	0,08	2,8	169	4840
145	600,00	47,88	2,3	180	4840
145	750,00	51,34	1,9	210	4840
145	900,00	0,06	1,6	210	4840
145	1200,00	59,05	1,2	210	4840
145	1500,00	63,26	0,9	210	4840
145	1800,00	0,04	0,8	210	4840
124	2400,00	64,74	0,6	210	4840
120	3000,00	0,02	0,5	210	4840
82	4000,00	0,01	0,4	210	4840
79	5000,00	57,45	0,3	210	4840

NRV-P030/063

Mn_2 [Nm]	i	Pn_1 [kW]	n_2 [rpm]	Fr_1 [N]	Fr_2 [N]
150	100,00	0,34	14,0	169	4967
211	150,00	0,34	9,3	169	5686
253	200,00	63,84	7,0	169	6259
231	250,00	0,24	5,6	169	6270
255	300,00	78,53	4,7	150	6270
255	400,00	80,43	3,5	169	6270
236	500,00	0,16	2,8	169	6270
271	600,00	0,15	2,3	180	6270
271	750,00	0,13	1,9	210	6270
271	900,00	0,11	1,6	210	6270
271	1200,00	0,09	1,2	210	6270
271	1500,00	0,08	0,9	210	6270
271	1800,00	0,07	0,8	210	6270
255	2400,00	128,37	0,6	210	6270
236	3000,00	0,04	0,5	210	6270
236	4000,00	0,04	0,4	210	6270
150	5000,00	106,13	0,3	210	6270

NRV040/050

Mn_2 [Nm]	i	Pn_1 [kW]	n_2 [rpm]	Fr_1 [N]	Fr_2 [N]
137	100,00	0,30	14,0	344	3800
135	150,00	0,21	9,3	344	4350
120	200,00	29,99	7,0	344	4788
110	250,00	0,12	5,6	344	4840
145	300,00	0,14	4,7	344	4840
124	400,00	39,60	3,5	344	4840
137	500,00	0,08	2,8	350	3800
145	600,00	44,85	2,3	350	4840
145	750,00	46,62	1,9	350	4840
135	900,00	45,95	1,6	350	4350
145	1200,00	53,68	1,2	350	4840
145	1500,00	0,04	0,9	350	4840
145	1800,00	0,03	0,8	350	4840
124	2400,00	57,06	0,6	350	4840
120	3000,00	0,02	0,5	350	4840
120	4000,00	0,02	0,4	350	4840
120	5000,00	0,01	0,3	350	4840

NRV-P040/063

Mn_2 [Nm]	i	Pn_1 [kW]	n_2 [rpm]	Fr_1 [N]	Fr_2 [N]
257	100,00	56,11	14,0	344	4967
260	150,00	0,40	9,3	344	5686
253	200,00	62,33	7,0	344	6259
231	250,00	0,24	5,6	344	6270
271	300,00	0,26	4,7	344	6270
255	400,00	78,53	3,5	344	6270
231	500,00	0,13	2,8	350	6270
271	600,00	0,14	2,3	350	6270
271	750,00	0,11	1,9	350	6270
271	900,00	0,10	1,6	350	6270
271	1200,00	0,08	1,2	350	6270
271	1500,00	0,07	0,9	350	6270
271	1800,00	0,06	0,8	350	6270
255	2400,00	113,14	0,6	350	6270
236	3000,00	0,04	0,5	350	6270
236	4000,00	125,53	0,4	350	6270
236	5000,00	138,61	0,3	350	6270

NRV-P040/075

Mn_2 [Nm]	i	Pn_1 [kW]	n_2 [rpm]	Fr_1 [N]	Fr_2 [N]
352	100,00	0,76	14,0	344	5863
425	150,00	0,64	9,3	344	6712
420	200,00	0,50	7,0	344	7380
380	250,00	0,38	5,6	344	7380
444	300,00	0,40	4,7	344	7380
414	400,00	121,02	3,5	344	7380
368	500,00	0,24	2,8	344	7380
444	600,00	0,21	2,3	350	7380
444	750,00	0,18	1,9	350	7380
444	900,00	0,16	1,6	350	7380
444	1200,00	0,13	1,2	350	7380
444	1500,00	0,11	0,9	350	7380
444	1800,00	0,10	0,8	350	7380
414	2400,00	174,35	0,6	350	7380
368	3000,00	169,33	0,5	350	7380
368	4000,00	0,05	0,4	350	7380
368	5000,00	208,13	0,3	350	7380

NRV-P040/090

Mn_2 [Nm]	i	Pn_1 [kW]	n2 [rpm]	Fr1 [N]	Fr2 [N]
361	100,00	0,76	14,0	344	6487
515	150,00	0,76	9,3	344	7426
610	200,00	0,70	7,0	344	8174
570	250,00	0,55	5,6	344	8180
700	300,00	0,60	4,7	344	8180
610	400,00	0,42	3,5	344	8180
560	500,00	0,33	2,8	344	8180
700	600,00	0,32	2,3	350	8180
700	750,00	201,53	1,9	350	8180
700	900,00	215,72	1,6	350	8180
700	1200,00	0,19	1,2	350	8180
700	1500,00	243,11	0,9	350	8180
700	1800,00	0,14	0,8	350	8180
610	2400,00	244,46	0,6	350	8180
560	3000,00	0,08	0,5	350	8180
560	4000,00	0,07	0,4	350	8180
560	5000,00	294,88	0,3	350	8180

NRV-P050/090

Mn_2 [Nm]	i	Pn_1 [kW]	n2 [rpm]	Fr1 [N]	Fr2 [N]
590	100,00	1,21	14,0	490	6487
660	150,00	0,95	9,3	490	7426
610	200,00	0,69	7,0	490	8174
570	250,00	0,53	5,6	490	8180
700	300,00	0,59	4,7	490	8180
610	400,00	0,41	3,5	490	8180
570	500,00	0,29	2,8	490	8180
700	600,00	0,32	2,3	490	8180
700	750,00	198,91	1,9	490	8180
700	900,00	0,23	1,6	490	8180
700	1200,00	0,19	1,2	490	8180
700	1500,00	239,31	0,9	490	8180
700	1800,00	0,14	0,8	490	8180
610	2400,00	0,10	0,6	490	8180
560	3000,00	0,08	0,5	490	8180
560	4000,00	0,07	0,4	490	8180
560	5000,00	0,06	0,3	490	8180

NRV-P050/110

Mn ₂ [Nm]	i	Pn ₁ [kW]	n ₂ [rpm]	Fr1 [N]	Fr2 [N]
648	100,00	1,33	14,0	490	8198
936	150,00	1,33	9,3	490	9384
1139	200,00	1,25	7,0	490	10320
1173	250,00	1,05	5,6	490	10320
1265	300,00	318,14	4,7	490	10320
1185	400,00	0,77	3,5	490	10320
1173	500,00	0,57	2,8	490	10320
1265	600,00	0,58	2,3	490	10320
1265	750,00	0,48	1,9	490	10320
1265	900,00	0,42	1,6	490	10320
1265	1200,00	0,34	1,2	490	10320
1265	1500,00	0,29	0,9	490	10320
1265	1800,00	0,26	0,8	490	10320
1185	2400,00	0,19	0,6	490	10320
1100	3000,00	433,49	0,5	490	10320
1100	4000,00	0,12	0,4	490	10320
1100	5000,00	520,18	0,3	490	10320

NRV-P063/110

Mn ₂ [Nm]	i	Pn ₁ [kW]	n ₂ [rpm]	Fr1 [N]	Fr2 [N]
1110	100,00	2,28	14,0	595	8198
1196	150,00	1,70	9,3	595	9384
1139	200,00	1,25	7,0	595	10320
1173	250,00	1,05	5,6	595	10320
1265	300,00	318,14	4,7	595	10320
1185	400,00	0,77	3,5	595	10320
1173	500,00	0,56	2,8	700	10320
1265	600,00	0,56	2,3	700	10320
1265	750,00	0,47	1,9	700	10320
1265	900,00	0,41	1,6	700	10320
1265	1200,00	389,84	1,2	700	10320
1265	1500,00	0,28	0,9	700	10320
1265	1800,00	0,24	0,8	700	10320
1185	2400,00	0,18	0,6	700	10320
1100	3000,00	0,14	0,5	700	10320
1100	4000,00	0,11	0,4	700	10320
1100	5000,00	0,10	0,3	700	10320

NRV-P063/130

Mn ₂ [Nm]	i	Pn ₁ [kW]	n ₂ [rpm]	Fr1 [N]	Fr2 [N]
1123	100,00	2,28	14,0	595	10722
1584	150,00	2,28	9,3	595	12274
1600	200,00	1,75	7,0	595	13500
1530	250,00	1,37	5,6	595	13500
1760	300,00	436,12	4,7	595	13500
1650	400,00	427,74	3,5	595	13500
1550	500,00	0,84	2,8	595	13500
1760	600,00	0,77	2,3	700	13500
1760	750,00	480,29	1,9	700	13500
1760	900,00	0,56	1,6	700	13500
1760	1200,00	534,40	1,2	700	13500
1760	1500,00	0,38	0,9	700	13500
1760	1800,00	0,33	0,8	700	13500
1650	2400,00	590,68	0,6	700	13500
1550	3000,00	581,73	0,5	700	13500
1550	4000,00	0,16	0,4	700	13500
1550	5000,00	0,14	0,3	700	13500

NRV-P063/150

Mn ₂ [Nm]	i	Pn ₁ [kW]	n ₂ [rpm]	Fr1 [N]	Fr2 [N]
1971	150,00	2,81	9,3	500	18000
2084	200,00	2,28	7,0	595	18000
2050	250,00	1,84	5,6	595	18000
2312	300,00	1,75	4,7	660	18000
2670	400,00	1,70	3,5	595	18000
2330	500,00	1,27	2,8	595	18000
2670	600,00	1,18	2,3	660	18000
2330	750,00	0,87	1,9	660	18000
2100	900,00	0,62	1,6	700	18000
2670	1200,00	0,66	1,2	700	18000
2330	1500,00	0,49	0,9	700	18000
2100	1800,00	0,37	0,8	700	18000
2670	2400,00	0,39	0,6	700	18000
2330	3000,00	0,29	0,5	700	18000
2330	4000,00	0,24	0,4	700	18000
2330	5000,00	1059,46	0,3	700	18000

NRV030

Mn ₂ [Nm]	i	Pn ₁ [kW]	n ₂ [rpm]	Fr1 [N]	Fr2 [N]
18	5,00	0,50	228,0	175	639
18	7,50	0,34	152,0	175	732
18	10,00	0,26	114,0	197	805
18	15,00	0,19	76,0	197	922
17	20,00	0,14	57,0	210	1015
21	25,00	0,15	46,0	210	1093
20	30,00	0,12	38,0	210	1162
18	40,00	0,09	29,0	210	1278
17	50,00	0,08	23,0	210	1377
15	60,00	0,06	19,0	210	1463
12	80,00	0,04	14,0	210	1611

NRV040

Mn ₂ [Nm]	i	Pn ₁ [kW]	n ₂ [rpm]	Fr1 [N]	Fr2 [N]
34	5,00	0,92	228,0	290	1230
40	7,50	0,74	152,0	327	1408
42	10,00	0,60	114,0	350	1550
42	15,00	0,41	76,0	350	1774
41	20,00	0,31	57,0	350	1953
37	25,00	0,24	46,0	350	2104
46	30,00	0,27	38,0	350	2235
43	40,00	0,20	29,0	350	2460
40	50,00	0,16	23,0	350	2650
36	60,00	0,13	19,0	350	2816
31	80,00	0,09	14,0	350	3100
28	100,00	0,07	11,0	350	3339

NRV050

Mn ₂ [Nm]	i	Pn ₁ [kW]	n ₂ [rpm]	Fr1 [N]	Fr2 [N]
65	5,00	1,74	228,0	400	1689
73	7,50	1,34	152,0	448	1933
75	10,00	1,04	114,0	490	2127
77	15,00	0,75	76,0	490	2435
74	20,00	0,56	57,0	490	2680
67	25,00	0,42	46,0	490	2887
84	30,00	0,47	38,0	490	3068
78	40,00	0,35	29,0	490	3377
73	50,00	0,28	23,0	490	3638
68	60,00	0,23	19,0	490	3866

NRV050

Mn_2 [Nm]	i	Pn_1 [kW]	n2 [rpm]	Fr1 [N]	Fr2 [N]
62	80,00	0,18	14,0	490	4255
52	100,00	0,13	11,0	490	4583

NRV-P063

Mn_2 [Nm]	i	Pn_1 [kW]	n2 [rpm]	Fr1 [N]	Fr2 [N]
122	7,50	2,19	152,0	580	2527
125	10,00	1,73	114,0	667	2781
140	15,00	1,34	76,0	700	3183
138	20,00	1,02	57,0	700	3504
127	25,00	0,78	46,0	700	3774
152	30,00	0,82	38,0	700	4011
142	40,00	0,61	29,0	700	4414
136	50,00	0,50	23,0	700	4755
128	60,00	0,41	19,0	700	5053
116	80,00	0,31	14,0	700	5562
112	100,00	0,27	11,0	700	5991

NRV-P075

Mn_2 [Nm]	i	Pn_1 [kW]	n2 [rpm]	Fr1 [N]	Fr2 [N]
176	7,50	3,16	152,0	810	2982
187	10,00	2,57	114,0	968	3282
215	15,00	2,03	76,0	980	3757
220	20,00	1,62	57,0	980	4135
202	25,00	1,22	46,0	980	4455
230	30,00	1,23	38,0	980	4734
230	40,00	0,98	29,0	980	5210
212	50,00	0,76	23,0	980	5613
200	60,00	0,63	19,0	980	5964
184	80,00	0,48	14,0	980	6565
171	100,00	0,39	11,0	980	7071

NRV-P090

Mn_2 [Nm]	i	Pn_1 [kW]	n2 [rpm]	Fr1 [N]	Fr2 [N]
303	7,50	5,38	152,0	1040	3300
324	10,00	4,39	114,0	1270	3632
376	15,00	3,47	76,0	1270	4157
370	20,00	2,64	57,0	1270	4576

NRV-P090

Mn_2 [Nm]	i	Pn_1 [kW]	n_2 [rpm]	Fr_1 [N]	Fr_2 [N]
355	25,00	2,07	46,0	1270	4929
410	30,00	2,10	38,0	1270	5238
376	40,00	1,51	29,0	1270	5765
355	50,00	1,19	23,0	1270	6210
334	60,00	0,98	19,0	1270	6599
271	80,00	0,65	14,0	1270	7264
257	100,00	0,53	11,0	1270	7824

NRV-P110

Mn_2 [Nm]	i	Pn_1 [kW]	n_2 [rpm]	Fr_1 [N]	Fr_2 [N]
612	20,00	4,29	57,0	1700	5782
645	25,00	3,68	46,0	1700	6228
690	30,00	3,48	38,0	1700	6619
667	40,00	2,57	29,0	1700	7285
627	50,00	2,01	23,0	1700	7847
585	60,00	1,62	19,0	1700	8339
490	80,00	1,10	14,0	1700	9178
459	100,00	0,88	11,0	1700	9887

NRV130

Mn_2 [Nm]	i	Pn_1 [kW]	n_2 [rpm]	Fr_1 [N]	Fr_2 [N]
930	50,00	3,04	23,0	2100	10264
855	60,00	2,43	19,0	2100	10907
798	80,00	1,83	14,0	2100	12005
703	100,00	1,40	11,0	2100	12931

NRV150

Mn_2 [Nm]	i	Pn_1 [kW]	n_2 [rpm]	Fr_1 [N]	Fr_2 [N]
1197	60,00	3,35	19,0	2800	14911
1093	80,00	2,47	14,0	2800	16411
950	100,00	1,86	11,0	2800	17679

NRV030/040

Mn ₂ [Nm]	i	Pn ₁ [kW]	n ₂ [rpm]	Fr1 [N]	Fr2 [N]
71	100,00	0,13	11,4	197	2769
72	150,00	0,10	7,6	197	3169
65	200,00	0,07	5,7	197	3488
61	250,00	0,05	4,6	197	3490
73	300,00	0,06	3,8	197	3490
65	400,00	0,04	2,9	197	3490
61	500,00	0,03	2,3	210	3490
73	600,00	0,03	1,9	210	3490
73	750,00	0,03	1,5	210	3490
73	900,00	0,03	1,3	210	3490
73	1200,00	0,02	1,0	210	3490
73	1500,00	0,02	0,8	210	3490
73	1800,00	29,54	0,6	210	3490
65	2400,00	0,01	0,5	210	3490
60	3000,00	0,01	0,4	210	3490
48	4000,00	0,01	0,3	210	3490
43	5000,00	0,01	0,2	210	3490

NRV030/050

Mn ₂ [Nm]	i	Pn ₁ [kW]	n ₂ [rpm]	Fr1 [N]	Fr2 [N]
137	100,00	0,25	11,4	197	3800
135	150,00	0,18	7,6	197	4350
120	200,00	0,13	5,7	197	4788
110	250,00	0,10	4,6	197	4840
145	300,00	0,12	3,8	197	4840
124	400,00	33,43	2,9	197	4840
120	500,00	34,94	2,3	197	4840
145	600,00	0,07	1,9	210	4840
145	750,00	0,06	1,5	210	4840
145	900,00	0,05	1,3	210	4840
145	1200,00	0,04	1,0	210	4840
145	1500,00	53,42	0,8	210	4840
145	1800,00	0,03	0,6	210	4840
124	2400,00	0,02	0,5	210	4840
120	3000,00	0,02	0,4	210	4840
82	4000,00	0,01	0,3	210	4840
79	5000,00	48,51	0,2	210	4840

NRV-P030/063

Mn_2 [Nm]	i	Pn_1 [kW]	n2 [rpm]	Fr1 [N]	Fr2 [N]
158	100,00	0,29	11,4	197	4967
222	150,00	0,29	7,6	197	5686
253	200,00	52,62	5,7	197	6259
231	250,00	0,20	4,6	197	6270
255	300,00	64,71	3,8	175	6270
255	400,00	66,29	2,9	197	6270
236	500,00	0,13	2,3	197	6270
271	600,00	0,12	1,9	210	6270
271	750,00	0,11	1,5	210	6270
271	900,00	0,09	1,3	210	6270
271	1200,00	0,08	1,0	210	6270
271	1500,00	0,07	0,8	210	6270
271	1800,00	0,06	0,6	210	6270
255	2400,00	108,71	0,5	210	6270
236	3000,00	108,35	0,4	210	6270
236	4000,00	0,03	0,3	210	6270
150	5000,00	0,02	0,2	210	6270

NRV040/050

Mn_2 [Nm]	i	Pn_1 [kW]	n2 [rpm]	Fr1 [N]	Fr2 [N]
137	100,00	24,64	11,4	350	3800
135	150,00	26,28	7,6	350	4350
120	200,00	0,12	5,7	350	4788
110	250,00	0,10	4,6	350	4840
145	300,00	34,34	3,8	350	4840
124	400,00	32,63	2,9	350	4840
137	500,00	0,07	2,3	350	3800
145	600,00	36,98	1,9	350	4840
145	750,00	38,46	1,5	350	4840
135	900,00	0,04	1,3	350	4350
145	1200,00	44,38	1,0	350	4840
145	1500,00	0,03	0,8	350	4840
145	1800,00	0,03	0,6	350	4840
124	2400,00	0,02	0,5	350	4840
120	3000,00	0,02	0,4	350	4840
120	4000,00	0,01	0,3	350	4840
120	5000,00	0,01	0,2	350	4840

NRV-P040/063

Mn_2 [Nm]	i	Pn_1 [kW]	n2 [rpm]	Fr1 [N]	Fr2 [N]
257	100,00	46,23	11,4	350	4967
260	150,00	0,33	7,6	350	5686
253	200,00	51,36	5,7	350	6259
231	250,00	0,20	4,6	350	6270
271	300,00	0,21	3,8	350	6270
255	400,00	64,71	2,9	350	6270
231	500,00	0,11	2,3	350	6270
271	600,00	0,11	1,9	350	6270
271	750,00	0,09	1,5	350	6270
271	900,00	0,09	1,3	350	6270
271	1200,00	0,07	1,0	350	6270
271	1500,00	0,06	0,8	350	6270
271	1800,00	0,05	0,6	350	6270
255	2400,00	95,36	0,5	350	6270
236	3000,00	0,03	0,4	350	6270
236	4000,00	0,03	0,3	350	6270
236	5000,00	0,02	0,2	350	6270

NRV-P040/075

Mn_2 [Nm]	i	Pn_1 [kW]	n2 [rpm]	Fr1 [N]	Fr2 [N]
368	100,00	0,65	11,4	350	5863
425	150,00	0,53	7,6	350	6712
420	200,00	0,41	5,7	350	7380
380	250,00	0,31	4,6	350	7380
444	300,00	0,33	3,8	350	7380
414	400,00	99,72	2,9	350	7380
368	500,00	0,19	2,3	350	7380
444	600,00	0,18	1,9	350	7380
444	750,00	0,15	1,5	350	7380
444	900,00	0,13	1,3	350	7380
444	1200,00	0,11	1,0	350	7380
444	1500,00	0,09	0,8	350	7380
444	1800,00	0,08	0,6	350	7380
414	2400,00	0,06	0,5	350	7380
368	3000,00	0,05	0,4	350	7380
368	4000,00	0,04	0,3	350	7380
368	5000,00	0,04	0,2	350	7380

NRV-P040/090

Mn ₂ [Nm]	i	Pn ₁ [kW]	n ₂ [rpm]	Fr1 [N]	Fr2 [N]
377	100,00	0,65	11,4	350	6487
538	150,00	0,65	7,6	350	7426
610	200,00	0,58	5,7	350	8174
570	250,00	0,45	4,6	350	8180
700	300,00	0,49	3,8	350	8180
610	400,00	0,35	2,9	350	8180
560	500,00	0,27	2,3	350	8180
700	600,00	0,27	1,9	350	8180
700	750,00	0,22	1,5	350	8180
700	900,00	180,75	1,3	350	8180
700	1200,00	0,16	1,0	350	8180
700	1500,00	0,14	0,8	350	8180
700	1800,00	218,80	0,6	350	8180
610	2400,00	0,09	0,5	350	8180
560	3000,00	202,20	0,4	350	8180
560	4000,00	0,06	0,3	350	8180
560	5000,00	0,05	0,2	350	8180

NRV-P050/090

Mn ₂ [Nm]	i	Pn ₁ [kW]	n ₂ [rpm]	Fr1 [N]	Fr2 [N]
590	100,00	1,00	11,4	490	6487
660	150,00	0,78	7,6	490	7426
610	200,00	0,56	5,7	490	8174
570	250,00	0,44	4,6	490	8180
700	300,00	0,48	3,8	490	8180
610	400,00	0,34	2,9	490	8180
570	500,00	119,62	2,3	490	8180
700	600,00	0,26	1,9	490	8180
700	750,00	0,22	1,5	490	8180
700	900,00	0,20	1,3	490	8180
700	1200,00	0,16	1,0	490	8180
700	1500,00	0,13	0,8	490	8180
700	1800,00	0,12	0,6	490	8180
610	2400,00	202,49	0,5	490	8180
560	3000,00	198,72	0,4	490	8180
560	4000,00	0,06	0,3	490	8180
560	5000,00	240,12	0,2	490	8180

NRV-P050/110

Mn ₂ [Nm]	i	Pn ₁ [kW]	n ₂ [rpm]	Fr1 [N]	Fr2 [N]
702	100,00	1,19	11,4	490	8198
1014	150,00	1,19	7,6	490	9384
1139	200,00	1,03	5,7	490	10320
1173	250,00	0,87	4,6	490	10320
1265	300,00	0,87	3,8	490	10320
1185	400,00	0,63	2,9	490	10320
1173	500,00	0,47	2,3	490	10320
1265	600,00	0,48	1,9	490	10320
1265	750,00	296,55	1,5	490	10320
1265	900,00	0,35	1,3	490	10320
1265	1200,00	0,28	1,0	490	10320
1265	1500,00	0,24	0,8	490	10320
1265	1800,00	0,22	0,6	490	10320
1185	2400,00	0,16	0,5	490	10320
1100	3000,00	0,12	0,4	490	10320
1100	4000,00	0,10	0,3	490	10320
1100	5000,00	441,23	0,2	490	10320

NRV-P063/110

Mn ₂ [Nm]	i	Pn ₁ [kW]	n ₂ [rpm]	Fr1 [N]	Fr2 [N]
1127	100,00	1,90	11,4	667	8198
1196	150,00	209,65	7,6	667	9384
1139	200,00	1,02	5,7	667	10320
1173	250,00	0,87	4,6	667	10320
1265	300,00	0,87	3,8	667	10320
1185	400,00	252,46	2,9	667	10320
1173	500,00	0,46	2,3	700	10320
1265	600,00	0,47	1,9	700	10320
1265	750,00	0,39	1,5	700	10320
1265	900,00	0,34	1,3	700	10320
1265	1200,00	0,27	1,0	700	10320
1265	1500,00	0,23	0,8	700	10320
1265	1800,00	0,20	0,6	700	10320
1185	2400,00	0,15	0,5	700	10320
1100	3000,00	0,11	0,4	700	10320
1100	4000,00	0,09	0,3	700	10320
1100	5000,00	420,22	0,2	700	10320

NRV-P063/130

Mn ₂ [Nm]	i	Pn ₁ [kW]	n ₂ [rpm]	Fr1 [N]	Fr2 [N]
1183	100,00	1,97	11,4	667	10722
1668	150,00	1,97	7,6	667	12274
1600	200,00	287,76	5,7	667	13500
1530	250,00	1,13	4,6	667	13500
1760	300,00	1,19	3,8	667	13500
1650	400,00	0,88	2,9	667	13500
1550	500,00	0,69	2,3	667	13500
1760	600,00	0,64	1,9	700	13500
1760	750,00	0,53	1,5	700	13500
1760	900,00	0,47	1,3	700	13500
1760	1200,00	0,37	1,0	700	13500
1760	1500,00	0,32	0,8	700	13500
1760	1800,00	0,28	0,6	700	13500
1650	2400,00	0,21	0,5	700	13500
1550	3000,00	486,04	0,4	700	13500
1550	4000,00	0,13	0,3	700	13500
1550	5000,00	592,12	0,2	700	13500

NRV-P063/150

Mn ₂ [Nm]	i	Pn ₁ [kW]	n ₂ [rpm]	Fr1 [N]	Fr2 [N]
2148	150,00	2,51	7,6	580	18000
2195	200,00	1,97	5,7	667	18000
2050	250,00	378,52	4,6	667	18000
2340	300,00	1,45	3,8	700	18000
2670	400,00	1,40	2,9	667	18000
2330	500,00	1,04	2,3	667	18000
2670	600,00	0,97	1,9	700	18000
2330	750,00	0,72	1,5	700	18000
2100	900,00	0,52	1,3	700	18000
2670	1200,00	0,55	1,0	700	18000
2330	1500,00	0,41	0,8	700	18000
2100	1800,00	0,31	0,6	700	18000
2670	2400,00	0,33	0,5	700	18000
2330	3000,00	0,24	0,4	700	18000
2330	4000,00	0,20	0,3	700	18000
2330	5000,00	0,18	0,2	700	18000

NRV030

Mn ₂ [Nm]	i	Pn ₁ [kW]	n ₂ [rpm]	Fr1 [N]	Fr2 [N]
18	5,00	0,40	180,0	175	692
18	7,50	0,27	120,0	175	792
18	10,00	0,21	90,0	197	871
18	15,00	0,15	60,0	197	997
17	20,00	0,11	45,0	210	1098
21	25,00	0,12	36,0	210	1183
20	30,00	0,10	30,0	210	1257
18	40,00	0,08	23,0	210	1383
17	50,00	0,06	18,0	210	1490
15	60,00	0,05	15,0	210	1583
12	80,00	0,03	11,0	210	1743

NRV040

Mn ₂ [Nm]	i	Pn ₁ [kW]	n ₂ [rpm]	Fr1 [N]	Fr2 [N]
34	5,00	0,74	180,0	290	1331
40	7,50	0,59	120,0	318	1524
42	10,00	0,48	90,0	350	1677
42	15,00	0,33	60,0	350	1920
41	20,00	0,25	45,0	350	2113
37	25,00	0,19	36,0	350	2276
46	30,00	0,22	30,0	350	2419
43	40,00	0,16	23,0	350	2662
40	50,00	0,13	18,0	350	2868
36	60,00	0,10	15,0	350	3047
31	80,00	0,07	11,0	350	3354
28	100,00	0,06	9,0	350	3490

NRV050

Mn ₂ [Nm]	i	Pn ₁ [kW]	n ₂ [rpm]	Fr1 [N]	Fr2 [N]
65	5,00	1,39	180,0	400	1827
73	7,50	1,07	120,0	444	2091
75	10,00	0,83	90,0	490	2302
77	15,00	0,60	60,0	490	2635
74	20,00	0,45	45,0	490	2900
67	25,00	0,34	36,0	490	3124
84	30,00	0,38	30,0	490	3320
78	40,00	0,29	23,0	490	3654
73	50,00	0,23	18,0	490	3936
68	60,00	0,19	15,0	490	4183

NRV050

Mn_2 [Nm]	i	Pn_1 [kW]	n_2 [rpm]	Fr1 [N]	Fr2 [N]
62	80,00	0,15	11,0	490	4604
52	100,00	0,11	9,0	490	4840

NRV-P063

Mn_2 [Nm]	i	Pn_1 [kW]	n_2 [rpm]	Fr1 [N]	Fr2 [N]
122	7,50	1,74	120,0	580	2734
125	10,00	1,39	90,0	661	3009
140	15,00	1,07	60,0	700	3444
138	20,00	0,83	45,0	700	3791
127	25,00	0,63	36,0	700	4084
152	30,00	0,67	30,0	700	4339
142	40,00	0,51	23,0	700	4776
136	50,00	0,41	18,0	700	5145
128	60,00	0,34	15,0	700	5467
116	80,00	0,26	11,0	700	6018
112	100,00	0,22	9,0	700	6270

NRV-P075

Mn_2 [Nm]	i	Pn_1 [kW]	n_2 [rpm]	Fr1 [N]	Fr2 [N]
176	7,50	2,51	120,0	810	3227
187	10,00	2,05	90,0	975	3551
215	15,00	1,63	60,0	980	4065
220	20,00	1,30	45,0	980	4474
202	25,00	0,98	36,0	980	4820
230	30,00	0,98	30,0	980	5122
230	40,00	0,79	23,0	980	5637
212	50,00	0,62	18,0	980	6073
200	60,00	0,51	15,0	980	6453
184	80,00	0,39	11,0	980	7103
171	100,00	0,32	9,0	980	7380

NRV-P090

Mn_2 [Nm]	i	Pn_1 [kW]	n_2 [rpm]	Fr1 [N]	Fr2 [N]
303	7,50	4,28	120,0	1040	3570
324	10,00	3,51	90,0	1270	3929
376	15,00	2,78	60,0	1270	4498
370	20,00	2,13	45,0	1270	4951

NRV-P090

Mn_2 [Nm]	i	Pn_1 [kW]	n2 [rpm]	Fr1 [N]	Fr2 [N]
355	25,00	1,67	36,0	1270	5333
410	30,00	1,69	30,0	1270	5667
376	40,00	1,23	23,0	1270	6238
355	50,00	0,97	18,0	1270	6719
334	60,00	0,81	15,0	1270	7140
271	80,00	0,53	11,0	1270	7859
257	100,00	0,44	9,0	1270	8180

NRV-P110

Mn_2 [Nm]	i	Pn_1 [kW]	n2 [rpm]	Fr1 [N]	Fr2 [N]
612	20,00	3,43	45,0	1700	6256
645	25,00	2,97	36,0	1700	6739
690	30,00	2,81	30,0	1700	7161
667	40,00	2,10	23,0	1700	7882
627	50,00	1,64	18,0	1700	8491
585	60,00	1,33	15,0	1700	9023
490	80,00	0,90	11,0	1700	9931
459	100,00	0,73	9,0	1700	10320

NRV130

Mn_2 [Nm]	i	Pn_1 [kW]	n2 [rpm]	Fr1 [N]	Fr2 [N]
930	50,00	2,40	18,0	2100	11105
855	60,00	1,92	15,0	2100	11801
798	80,00	1,45	11,0	2100	12989
703	100,00	1,10	9,0	2100	13500

NRV150

Mn_2 [Nm]	i	Pn_1 [kW]	n2 [rpm]	Fr1 [N]	Fr2 [N]
1197	60,00	2,65	15,0	2800	16133
1093	80,00	1,95	11,0	2800	17757
950	100,00	1,47	9,0	2800	18000

NRV030/040

Mn ₂ [Nm]	i	Pn ₁ [kW]	n ₂ [rpm]	Fr1 [N]	Fr2 [N]
71	100,00	0,11	9,0	197	2769
72	150,00	0,08	6,0	197	3169
65	200,00	0,05	4,5	197	3488
61	250,00	10,92	3,6	197	3490
73	300,00	0,05	3,0	197	3490
65	400,00	0,04	2,3	197	3490
61	500,00	0,03	1,8	210	3490
73	600,00	0,03	1,5	210	3490
73	750,00	0,02	1,2	210	3490
73	900,00	0,02	1,0	210	3490
73	1200,00	20,82	0,8	210	3490
73	1500,00	0,01	0,6	210	3490
73	1800,00	0,01	0,5	210	3490
65	2400,00	0,01	0,4	210	3490
60	3000,00	0,01	0,3	210	3490
48	4000,00	0,01	0,2	210	3490
43	5000,00	0,00	0,2	210	3490

NRV030/050

Mn ₂ [Nm]	i	Pn ₁ [kW]	n ₂ [rpm]	Fr1 [N]	Fr2 [N]
137	100,00	20,18	9,0	197	3800
135	150,00	0,14	6,0	197	4350
120	200,00	0,10	4,5	197	4788
110	250,00	0,08	3,6	197	4840
145	300,00	28,12	3,0	197	4840
124	400,00	0,07	2,3	197	4840
120	500,00	0,06	1,8	197	4840
145	600,00	0,05	1,5	210	4840
145	750,00	35,04	1,2	210	4840
145	900,00	0,04	1,0	210	4840
145	1200,00	0,03	0,8	210	4840
145	1500,00	43,80	0,6	210	4840
145	1800,00	0,03	0,5	210	4840
124	2400,00	0,02	0,4	210	4840
120	3000,00	0,02	0,3	210	4840
82	4000,00	0,01	0,2	210	4840
79	5000,00	0,01	0,2	210	4840

NRV-P030/063

Mn_2 [Nm]	i	Pn_1 [kW]	n2 [rpm]	Fr1 [N]	Fr2 [N]
166	100,00	0,24	9,0	197	4967
233	150,00	0,24	6,0	197	5686
253	200,00	42,05	4,5	197	6259
231	250,00	40,11	3,6	197	6270
255	300,00	51,70	3,0	175	6270
255	400,00	52,98	2,3	197	6270
236	500,00	52,80	1,8	197	6270
271	600,00	0,10	1,5	210	6270
271	750,00	0,09	1,2	210	6270
271	900,00	0,08	1,0	210	6270
271	1200,00	0,06	0,8	210	6270
271	1500,00	0,05	0,6	210	6270
271	1800,00	0,05	0,5	210	6270
255	2400,00	89,40	0,4	210	6270
236	3000,00	89,11	0,3	210	6270
236	4000,00	0,03	0,2	210	6270
150	5000,00	0,01	0,2	210	6270

NRV040/050

Mn_2 [Nm]	i	Pn_1 [kW]	n2 [rpm]	Fr1 [N]	Fr2 [N]
137	100,00	0,20	9,0	350	3800
135	150,00	21,00	6,0	350	4350
120	200,00	0,10	4,5	350	4788
110	250,00	19,21	3,6	350	4840
145	300,00	27,44	3,0	350	4840
124	400,00	0,07	2,3	350	4840
137	500,00	0,06	1,8	350	3800
145	600,00	0,05	1,5	350	4840
145	750,00	31,20	1,2	350	4840
135	900,00	0,04	1,0	350	4350
145	1200,00	0,03	0,8	350	4840
145	1500,00	39,27	0,6	350	4840
145	1800,00	0,02	0,5	350	4840
124	2400,00	0,02	0,4	350	4840
120	3000,00	0,01	0,3	350	4840
120	4000,00	0,01	0,2	350	4840
120	5000,00	0,01	0,2	350	4840

NRV-P040/063

Mn_2 [Nm]	i	Pn_1 [kW]	n2 [rpm]	Fr1 [N]	Fr2 [N]
257	100,00	36,94	9,0	350	4967
260	150,00	0,27	6,0	350	5686
253	200,00	0,21	4,5	350	6259
231	250,00	0,16	3,6	350	6270
271	300,00	0,17	3,0	350	6270
255	400,00	51,70	2,3	350	6270
231	500,00	0,09	1,8	350	6270
271	600,00	0,09	1,5	350	6270
271	750,00	0,08	1,2	350	6270
271	900,00	0,07	1,0	350	6270
271	1200,00	0,06	0,8	350	6270
271	1500,00	0,05	0,6	350	6270
271	1800,00	0,04	0,5	350	6270
255	2400,00	78,02	0,4	350	6270
236	3000,00	0,03	0,3	350	6270
236	4000,00	87,29	0,2	350	6270
236	5000,00	0,02	0,2	350	6270

NRV-P040/075

Mn_2 [Nm]	i	Pn_1 [kW]	n2 [rpm]	Fr1 [N]	Fr2 [N]
384	100,00	0,55	9,0	350	5863
425	150,00	0,42	6,0	350	6712
420	200,00	0,33	4,5	350	7380
380	250,00	0,25	3,6	350	7380
444	300,00	0,26	3,0	350	7380
414	400,00	0,20	2,3	350	7380
368	500,00	0,15	1,8	350	7380
444	600,00	0,14	1,5	350	7380
444	750,00	0,12	1,2	350	7380
444	900,00	0,11	1,0	350	7380
444	1200,00	0,09	0,8	350	7380
444	1500,00	0,08	0,6	350	7380
444	1800,00	0,07	0,5	350	7380
414	2400,00	0,05	0,4	350	7380
368	3000,00	0,04	0,3	350	7380
368	4000,00	131,07	0,2	350	7380
368	5000,00	0,03	0,2	350	7380

NRV-P040/090

Mn_2 [Nm]	i	Pn_1 [kW]	n2 [rpm]	Fr1 [N]	Fr2 [N]
394	100,00	0,55	9,0	350	6487
562	150,00	0,55	6,0	350	7426
610	200,00	0,46	4,5	350	8174
570	250,00	89,89	3,6	350	8180
700	300,00	0,40	3,0	350	8180
610	400,00	0,28	2,3	350	8180
560	500,00	0,22	1,8	350	8180
700	600,00	0,22	1,5	350	8180
700	750,00	0,18	1,2	350	8180
700	900,00	0,16	1,0	350	8180
700	1200,00	0,13	0,8	350	8180
700	1500,00	0,11	0,6	350	8180
700	1800,00	0,10	0,5	350	8180
610	2400,00	0,07	0,4	350	8180
560	3000,00	0,06	0,3	350	8180
560	4000,00	0,05	0,2	350	8180
560	5000,00	206,80	0,2	350	8180

NRV-P050/090

Mn_2 [Nm]	i	Pn_1 [kW]	n2 [rpm]	Fr1 [N]	Fr2 [N]
590	100,00	0,80	9,0	490	6487
660	150,00	0,63	6,0	490	7426
610	200,00	0,45	4,5	490	8174
570	250,00	0,35	3,6	490	8180
700	300,00	0,39	3,0	490	8180
610	400,00	0,27	2,3	490	8180
570	500,00	96,89	1,8	490	8180
700	600,00	0,21	1,5	490	8180
700	750,00	0,18	1,2	490	8180
700	900,00	142,70	1,0	490	8180
700	1200,00	153,84	0,8	490	8180
700	1500,00	0,11	0,6	490	8180
700	1800,00	0,10	0,5	490	8180
610	2400,00	0,07	0,4	490	8180
560	3000,00	0,05	0,3	490	8180
560	4000,00	0,04	0,2	490	8180
560	5000,00	0,04	0,2	490	8180

NRV-P050/110

Mn_2 [Nm]	i	Pn_1 [kW]	n2 [rpm]	Fr1 [N]	Fr2 [N]
754	100,00	1,02	9,0	490	8198
1090	150,00	1,02	6,0	490	9384
1139	200,00	0,82	4,5	490	10320
1173	250,00	0,69	3,6	490	10320
1265	300,00	0,70	3,0	490	10320
1185	400,00	202,13	2,3	490	10320
1173	500,00	0,38	1,8	490	10320
1265	600,00	0,39	1,5	490	10320
1265	750,00	0,32	1,2	490	10320
1265	900,00	0,29	1,0	490	10320
1265	1200,00	0,23	0,8	490	10320
1265	1500,00	0,20	0,6	490	10320
1265	1800,00	0,18	0,5	490	10320
1185	2400,00	0,13	0,4	490	10320
1100	3000,00	0,10	0,3	490	10320
1100	4000,00	0,08	0,2	490	10320
1100	5000,00	371,56	0,2	490	10320

NRV-P063/110

Mn_2 [Nm]	i	Pn_1 [kW]	n2 [rpm]	Fr1 [N]	Fr2 [N]
1127	100,00	1,52	9,0	661	8198
1196	150,00	1,12	6,0	661	9384
1139	200,00	0,82	4,5	661	10320
1173	250,00	0,69	3,6	661	10320
1265	300,00	0,70	3,0	661	10320
1185	400,00	202,13	2,3	661	10320
1173	500,00	0,38	1,8	700	10320
1265	600,00	0,38	1,5	700	10320
1265	750,00	0,31	1,2	700	10320
1265	900,00	0,28	1,0	700	10320
1265	1200,00	0,22	0,8	700	10320
1265	1500,00	0,19	0,6	700	10320
1265	1800,00	0,17	0,5	700	10320
1185	2400,00	0,12	0,4	700	10320
1100	3000,00	0,09	0,3	700	10320
1100	4000,00	0,08	0,2	700	10320
1100	5000,00	348,34	0,2	700	10320

NRV-P063/130

Mn_2 [Nm]	i	Pn_1 [kW]	n2 [rpm]	Fr1 [N]	Fr2 [N]
1270	100,00	1,70	9,0	661	10722
1700	150,00	1,61	6,0	661	12274
1600	200,00	230,38	4,5	661	13500
1530	250,00	0,90	3,6	661	13500
1760	300,00	286,96	3,0	661	13500
1650	400,00	0,70	2,3	661	13500
1550	500,00	277,18	1,8	661	13500
1760	600,00	0,52	1,5	700	13500
1760	750,00	0,43	1,2	700	13500
1760	900,00	0,38	1,0	700	13500
1760	1200,00	0,31	0,8	700	13500
1760	1500,00	0,26	0,6	700	13500
1760	1800,00	0,23	0,5	700	13500
1650	2400,00	405,47	0,4	700	13500
1550	3000,00	0,13	0,3	700	13500
1550	4000,00	0,11	0,2	700	13500
1550	5000,00	0,10	0,2	700	13500

NRV-P063/150

Mn_2 [Nm]	i	Pn_1 [kW]	n2 [rpm]	Fr1 [N]	Fr2 [N]
2325	150,00	2,16	6,0	580	18000
2340	200,00	1,68	4,5	661	18000
2050	250,00	1,21	3,6	661	18000
2340	300,00	1,16	3,0	700	18000
2670	400,00	1,12	2,3	661	18000
2330	500,00	416,66	1,8	661	18000
2670	600,00	0,77	1,5	700	18000
2330	750,00	0,58	1,2	700	18000
2100	900,00	0,42	1,0	700	18000
2670	1200,00	0,45	0,8	700	18000
2330	1500,00	0,33	0,6	700	18000
2100	1800,00	0,26	0,5	700	18000
2670	2400,00	0,27	0,4	700	18000
2330	3000,00	600,28	0,3	700	18000
2330	4000,00	0,17	0,2	700	18000
2330	5000,00	0,15	0,2	700	18000

NRV030

Mn_2 [Nm]	i	Pn_1 [kW]	n_2 [rpm]	Fr_1 [N]	Fr_2 [N]
18	5,00	0,22	100,0	210	841
18	7,50	0,16	67,0	210	963
18	10,00	0,12	50,0	210	1060
18	15,00	0,09	33,0	210	1213
17	20,00	0,07	25,0	210	1336
21	25,00	0,07	20,0	210	1439
20	30,00	0,06	17,0	210	1529
18	40,00	0,04	13,0	210	1683
17	50,00	0,04	10,0	210	1813
15	60,00	0,03	8,0	210	1830
12	80,00	0,02	6,0	210	1830

NRV040

Mn_2 [Nm]	i	Pn_1 [kW]	n_2 [rpm]	Fr_1 [N]	Fr_2 [N]
34	5,00	0,41	100,0	350	1619
40	7,50	0,34	67,0	350	1853
42	10,00	0,27	50,0	350	2040
42	15,00	0,19	33,0	350	2335
41	20,00	0,15	25,0	350	2570
37	25,00	0,11	20,0	350	2769
46	30,00	0,13	17,0	350	2942
43	40,00	0,10	13,0	350	3238
40	50,00	0,08	10,0	350	3488
36	60,00	0,06	8,0	350	3490
31	80,00	0,05	6,0	350	3490
28	100,00	0,04	5,0	350	3490

NRV050

Mn_2 [Nm]	i	Pn_1 [kW]	n_2 [rpm]	Fr_1 [N]	Fr_2 [N]
65	5,00	0,79	100,0	490	2222
73	7,50	0,61	67,0	490	2544
75	10,00	0,48	50,0	490	2800
77	15,00	0,35	33,0	490	3205
74	20,00	0,26	25,0	490	3528
67	25,00	0,20	20,0	490	3800
84	30,00	0,23	17,0	490	4038
78	40,00	0,17	13,0	490	4445
73	50,00	0,14	10,0	490	4788
68	60,00	0,11	8,0	490	4840

NRV050

Mn_2 [Nm]	i	Pn_1 [kW]	n2 [rpm]	Fr1 [N]	Fr2 [N]
62	80,00	0,09	6,0	490	4840
52	100,00	0,07	5,0	490	4840

NRV-P063

Mn_2 [Nm]	i	Pn_1 [kW]	n2 [rpm]	Fr1 [N]	Fr2 [N]
122	7,50	0,99	67,0	700	3325
125	10,00	0,80	50,0	700	3660
140	15,00	0,63	33,0	700	4190
138	20,00	0,48	25,0	700	4611
127	25,00	0,37	20,0	700	4967
152	30,00	0,40	17,0	700	5279
142	40,00	0,30	13,0	700	5810
136	50,00	0,25	10,0	700	6259
128	60,00	0,21	8,0	700	6270
116	80,00	0,16	6,0	700	6270
112	100,00	0,14	5,0	700	6270

NRV-P075

Mn_2 [Nm]	i	Pn_1 [kW]	n2 [rpm]	Fr1 [N]	Fr2 [N]
176	7,50	1,45	67,0	980	3925
187	10,00	1,18	50,0	980	4320
215	15,00	0,94	33,0	980	4945
220	20,00	0,75	25,0	980	5443
202	25,00	0,57	20,0	980	5863
230	30,00	0,58	17,0	980	6231
230	40,00	0,47	13,0	980	6858
212	50,00	0,37	10,0	980	7380
200	60,00	0,31	8,0	980	7380
184	80,00	0,24	6,0	980	7380
171	100,00	0,19	5,0	980	7380

NRV-P090

Mn_2 [Nm]	i	Pn_1 [kW]	n2 [rpm]	Fr1 [N]	Fr2 [N]
303	7,50	2,46	67,0	1270	4343
324	10,00	2,00	50,0	1270	4780
376	15,00	1,60	33,0	1270	5472
370	20,00	1,23	25,0	1270	6022

NRV-P090

Mn_2 [Nm]	i	Pn_1 [kW]	n_2 [rpm]	Fr_1 [N]	Fr_2 [N]
355	25,00	0,98	20,0	1270	6487
410	30,00	0,99	17,0	1270	6894
376	40,00	0,73	13,0	1270	7588
355	50,00	0,58	10,0	1270	8174
334	60,00	0,49	8,0	1270	8180
271	80,00	0,33	6,0	1270	8180
257	100,00	0,27	5,0	1270	8180

NRV-P110

Mn_2 [Nm]	i	Pn_1 [kW]	n_2 [rpm]	Fr_1 [N]	Fr_2 [N]
612	20,00	1,98	25,0	1700	7610
645	25,00	1,71	20,0	1700	8198
690	30,00	1,65	17,0	1700	8711
667	40,00	1,23	13,0	1700	9588
627	50,00	0,98	10,0	1700	10320
585	60,00	0,80	8,0	1700	10320
490	80,00	0,55	6,0	1700	10320
459	100,00	0,45	5,0	1700	10320

NRV130

Mn_2 [Nm]	i	Pn_1 [kW]	n_2 [rpm]	Fr_1 [N]	Fr_2 [N]
930	50,00	1,43	10,0	2100	13500
855	60,00	1,17	8,0	2100	13500
798	80,00	0,89	6,0	2100	13500
703	100,00	0,68	5,0	2100	13500

NRV150

Mn_2 [Nm]	i	Pn_1 [kW]	n_2 [rpm]	Fr_1 [N]	Fr_2 [N]
1197	60,00	1,61	8,0	2800	18000
1093	80,00	1,19	6,0	2800	18000
950	100,00	0,90	5,0	2800	18000

NRV030/040

Mn ₂ [Nm]	i	Pn ₁ [kW]	n ₂ [rpm]	Fr1 [N]	Fr2 [N]
71	100,00	0,06	5,0	210	2769
72	150,00	0,04	3,3	210	3169
65	200,00	0,03	2,5	210	3488
61	250,00	6,30	2,0	210	3490
73	300,00	0,03	1,7	210	3490
65	400,00	0,02	1,3	210	3490
61	500,00	0,01	1,0	210	3490
73	600,00	9,53	0,8	210	3490
73	750,00	0,01	0,7	210	3490
73	900,00	11,17	0,6	210	3490
73	1200,00	0,01	0,4	210	3490
73	1500,00	0,01	0,3	210	3490
73	1800,00	14,72	0,3	210	3490
65	2400,00	14,59	0,2	210	3490
60	3000,00	0,01	0,2	210	3490
48	4000,00	0,00	0,1	210	3490
43	5000,00	0,00	0,1	210	3490

NRV030/050

Mn ₂ [Nm]	i	Pn ₁ [kW]	n ₂ [rpm]	Fr1 [N]	Fr2 [N]
137	100,00	0,12	5,0	210	3800
135	150,00	0,08	3,3	210	4350
120	200,00	0,06	2,5	210	4788
110	250,00	0,04	2,0	210	4840
145	300,00	16,22	1,7	210	4840
124	400,00	15,41	1,3	210	4840
120	500,00	16,11	1,0	210	4840
145	600,00	0,03	0,8	210	4840
145	750,00	0,03	0,7	210	4840
145	900,00	21,82	0,6	210	4840
145	1200,00	23,87	0,4	210	4840
145	1500,00	26,36	0,3	210	4840
145	1800,00	0,02	0,3	210	4840
124	2400,00	27,32	0,2	210	4840
120	3000,00	28,56	0,2	210	4840
82	4000,00	0,01	0,1	210	4840
79	5000,00	23,94	0,1	210	4840

NRV-P030/063

Mn_2 [Nm]	i	Pn_1 [kW]	n_2 [rpm]	Fr_1 [N]	Fr_2 [N]
198	100,00	0,17	5,0	210	4967
260	150,00	0,16	3,3	210	5686
253	200,00	24,26	2,5	210	6259
231	250,00	0,09	2,0	210	6270
255	300,00	29,43	1,7	210	6270
255	400,00	30,56	1,3	210	6270
236	500,00	30,46	1,0	210	6270
271	600,00	0,06	0,8	210	6270
271	750,00	0,05	0,7	210	6270
271	900,00	0,04	0,6	210	6270
271	1200,00	0,04	0,4	210	6270
271	1500,00	0,03	0,3	210	6270
271	1800,00	0,03	0,3	210	6270
255	2400,00	54,18	0,2	210	6270
236	3000,00	54,00	0,2	210	6270
236	4000,00	62,53	0,1	210	6270
150	5000,00	44,22	0,1	210	6270

NRV040/050

Mn_2 [Nm]	i	Pn_1 [kW]	n_2 [rpm]	Fr_1 [N]	Fr_2 [N]
137	100,00	0,11	5,0	350	3800
135	150,00	0,08	3,3	350	4350
120	200,00	0,06	2,5	350	4788
110	250,00	0,04	2,0	350	4840
145	300,00	15,62	1,7	350	4840
124	400,00	0,04	1,3	350	4840
137	500,00	0,03	1,0	350	3800
145	600,00	0,03	0,8	350	4840
145	750,00	0,02	0,7	350	4840
135	900,00	0,02	0,6	350	4350
145	1200,00	0,02	0,4	350	4840
145	1500,00	0,01	0,3	350	4840
145	1800,00	0,01	0,3	350	4840
124	2400,00	0,01	0,2	350	4840
120	3000,00	24,64	0,2	350	4840
120	4000,00	0,01	0,1	350	4840
120	5000,00	0,01	0,1	350	4840

NRV-P040/063

Mn_2 [Nm]	i	Pn_1 [kW]	n_2 [rpm]	Fr_1 [N]	Fr_2 [N]
257	100,00	21,03	5,0	350	4967
260	150,00	0,15	3,3	350	5686
253	200,00	23,36	2,5	350	6259
231	250,00	0,09	2,0	350	6270
271	300,00	0,10	1,7	350	6270
255	400,00	29,43	1,3	350	6270
231	500,00	0,05	1,0	350	6270
271	600,00	0,05	0,8	350	6270
271	750,00	0,04	0,7	350	6270
271	900,00	0,04	0,6	350	6270
271	1200,00	0,03	0,4	350	6270
271	1500,00	0,03	0,3	350	6270
271	1800,00	0,03	0,3	350	6270
255	2400,00	46,75	0,2	350	6270
236	3000,00	0,02	0,2	350	6270
236	4000,00	52,80	0,1	350	6270
236	5000,00	59,40	0,1	350	6270

NRV-P040/075

Mn_2 [Nm]	i	Pn_1 [kW]	n_2 [rpm]	Fr_1 [N]	Fr_2 [N]
405	100,00	0,33	5,0	350	5863
425	150,00	0,24	3,3	350	6712
420	200,00	0,19	2,5	350	7380
380	250,00	0,14	2,0	350	7380
444	300,00	0,15	1,7	350	7380
414	400,00	0,11	1,3	350	7380
368	500,00	0,09	1,0	350	7380
444	600,00	0,08	0,8	350	7380
444	750,00	0,07	0,7	350	7380
444	900,00	0,06	0,6	350	7380
444	1200,00	0,05	0,4	350	7380
444	1500,00	0,04	0,3	350	7380
444	1800,00	0,04	0,3	350	7380
414	2400,00	0,03	0,2	350	7380
368	3000,00	0,02	0,2	350	7380
368	4000,00	79,29	0,1	350	7380
368	5000,00	89,20	0,1	350	7380

NRV-P040/090

Mn_2 [Nm]	i	Pn_1 [kW]	n2 [rpm]	Fr1 [N]	Fr2 [N]
484	100,00	0,38	5,0	350	6487
660	150,00	0,36	3,3	350	7426
610	200,00	0,26	2,5	350	8174
570	250,00	51,17	2,0	350	8180
700	300,00	0,23	1,7	350	8180
610	400,00	0,16	1,3	350	8180
560	500,00	0,12	1,0	350	8180
700	600,00	0,12	0,8	350	8180
700	750,00	0,10	0,7	350	8180
700	900,00	0,09	0,6	350	8180
700	1200,00	0,08	0,4	350	8180
700	1500,00	0,07	0,3	350	8180
700	1800,00	0,06	0,3	350	8180
610	2400,00	101,00	0,2	350	8180
560	3000,00	0,03	0,2	350	8180
560	4000,00	0,03	0,1	350	8180
560	5000,00	0,03	0,1	350	8180

NRV-P050/090

Mn_2 [Nm]	i	Pn_1 [kW]	n2 [rpm]	Fr1 [N]	Fr2 [N]
590	100,00	0,46	5,0	490	6487
660	150,00	0,36	3,3	490	7426
610	200,00	0,26	2,5	490	8174
570	250,00	50,55	2,0	490	8180
700	300,00	66,71	1,7	490	8180
610	400,00	0,16	1,3	490	8180
570	500,00	0,11	1,0	490	8180
700	600,00	0,12	0,8	490	8180
700	750,00	0,10	0,7	490	8180
700	900,00	0,09	0,6	490	8180
700	1200,00	91,17	0,4	490	8180
700	1500,00	0,07	0,3	490	8180
700	1800,00	0,06	0,3	490	8180
610	2400,00	99,06	0,2	490	8180
560	3000,00	0,03	0,2	490	8180
560	4000,00	0,03	0,1	490	8180
560	5000,00	0,03	0,1	490	8180

NRV-P050/110

Mn ₂ [Nm]	i	Pn ₁ [kW]	n ₂ [rpm]	Fr1 [N]	Fr2 [N]
927	100,00	0,72	5,0	490	8198
1196	150,00	0,64	3,3	490	9384
1139	200,00	0,47	2,5	490	10320
1173	250,00	0,40	2,0	490	10320
1265	300,00	0,40	1,7	490	10320
1185	400,00	0,29	1,3	490	10320
1173	500,00	0,22	1,0	490	10320
1265	600,00	133,58	0,8	490	10320
1265	750,00	0,19	0,7	490	10320
1265	900,00	0,17	0,6	490	10320
1265	1200,00	164,75	0,4	490	10320
1265	1500,00	0,12	0,3	490	10320
1265	1800,00	0,11	0,3	490	10320
1185	2400,00	0,08	0,2	490	10320
1100	3000,00	0,06	0,2	490	10320
1100	4000,00	0,05	0,1	490	10320
1100	5000,00	0,04	0,1	490	10320

NRV-P063/110

Mn ₂ [Nm]	i	Pn ₁ [kW]	n ₂ [rpm]	Fr1 [N]	Fr2 [N]
1127	100,00	0,88	5,0	700	8198
1196	150,00	0,64	3,3	700	9384
1139	200,00	0,47	2,5	700	10320
1173	250,00	0,40	2,0	700	10320
1265	300,00	0,40	1,7	700	10320
1185	400,00	0,29	1,3	700	10320
1173	500,00	0,22	1,0	700	10320
1265	600,00	131,80	0,8	700	10320
1265	750,00	0,18	0,7	700	10320
1265	900,00	0,17	0,6	700	10320
1265	1200,00	0,13	0,4	700	10320
1265	1500,00	0,12	0,3	700	10320
1265	1800,00	0,10	0,3	700	10320
1185	2400,00	0,07	0,2	700	10320
1100	3000,00	0,06	0,2	700	10320
1100	4000,00	0,05	0,1	700	10320
1100	5000,00	0,04	0,1	700	10320

NRV-P063/130

Mn ₂ [Nm]	i	Pn ₁ [kW]	n ₂ [rpm]	Fr1 [N]	Fr2 [N]
1530	100,00	1,18	5,0	700	10722
1700	150,00	0,93	3,3	700	12274
1600	200,00	0,66	2,5	700	13500
1530	250,00	130,25	2,0	700	13500
1760	300,00	0,55	1,7	700	13500
1650	400,00	0,41	1,3	700	13500
1550	500,00	0,32	1,0	700	13500
1760	600,00	180,68	0,8	700	13500
1760	750,00	0,25	0,7	700	13500
1760	900,00	205,32	0,6	700	13500
1760	1200,00	218,56	0,4	700	13500
1760	1500,00	0,16	0,3	700	13500
1760	1800,00	250,94	0,3	700	13500
1650	2400,00	246,12	0,2	700	13500
1550	3000,00	242,39	0,2	700	13500
1550	4000,00	0,07	0,1	700	13500
1550	5000,00	0,06	0,1	700	13500

NRV-P063/150

Mn ₂ [Nm]	i	Pn ₁ [kW]	n ₂ [rpm]	Fr1 [N]	Fr2 [N]
2340	150,00	1,23	3,3	700	18000
2340	200,00	0,97	2,5	700	18000
2050	250,00	174,52	2,0	700	18000
2340	300,00	0,68	1,7	700	18000
2670	400,00	258,30	1,3	700	18000
2330	500,00	0,48	1,0	700	18000
2670	600,00	0,45	0,8	700	18000
2330	750,00	0,34	0,7	700	18000
2100	900,00	228,20	0,6	700	18000
2670	1200,00	0,27	0,4	700	18000
2330	1500,00	0,20	0,3	700	18000
2100	1800,00	0,15	0,3	700	18000
2670	2400,00	0,16	0,2	700	18000
2330	3000,00	0,12	0,2	700	18000
2330	4000,00	0,10	0,1	700	18000
2330	5000,00	0,09	0,1	700	18000

IHW040+NMRV-P090

Mn ₂ [Nm]	i	Pn ₁ [kW]	n ₂ [rpm]	Fr1 [N]	Fr2 [N]
408	23,29	3,83	75,1	300	4343
460	31,05	3,27	56,4	400	4780
492	42,00	2,63	41,7	400	4780
518	46,58	2,54	37,6	400	5472
573	63,00	2,12	27,8	400	5472
444	77,63	1,41	22,5	400	6487
549	84,00	1,59	20,8	400	6022
556	93,16	1,54	18,8	400	6894
601	110,00	1,35	15,9	400	6022
615	126,00	1,31	13,9	400	6894
591	137,50	1,10	12,7	400	6487
468	155,26	0,87	11,3	400	8174
673	165,00	1,12	10,6	400	6894
418	186,32	0,69	9,4	400	8180
614	220,00	0,82	8,0	400	7588
469	252,00	0,60	6,9	400	8180
573	275,00	0,65	6,4	400	8174
552	304,55	0,57	5,8	400	8180
503	330,00	0,51	5,3	400	8180
612	383,33	0,51	4,6	400	8180
624	437,50	0,46	4,0	400	8180
534	460,00	0,40	3,8	400	8180
544	525,00	0,36	3,3	400	8180
426	613,33	0,27	2,9	400	8180
432	700,00	0,24	2,5	400	8180
351	766,67	0,19	2,3	400	8180
354	875,00	0,17	2,0	400	8180

IHW040+NMRV-P110

Mn ₂ [Nm]	i	Pn ₁ [kW]	n ₂ [rpm]	Fr1 [N]	Fr2 [N]
411	23,29	3,80	75,1	300	5488
535	31,05	3,80	56,4	300	6040
492	42,00	2,63	41,7	500	6040
780	46,58	3,77	37,6	300	6914
783	62,11	2,91	28,2	500	7610
829	77,63	2,53	22,5	500	8198
930	84,00	2,62	20,8	500	7610
917	93,16	2,50	18,8	500	8711
1014	105,00	2,34	16,7	500	8198
1109	126,00	2,33	13,9	500	8711
938	137,50	1,68	12,7	500	8198

IHW040+NMRV-P110

Mn_2 [Nm]	i	Pn_1 [kW]	n2 [rpm]	Fr1 [N]	Fr2 [N]
828	155,26	1,48	11,3	500	10320
1016	168,00	1,65	10,4	500	9588
739	186,32	1,15	9,4	500	10320
1115	220,00	1,42	8,0	500	9588
836	252,00	1,01	6,9	500	10320
1029	275,00	1,11	6,4	500	10320
978	304,55	0,96	5,8	500	10320
900	330,00	0,85	5,3	500	10320
937	383,33	0,74	4,6	500	10320
750	440,00	0,59	4,0	500	10320
959	460,00	0,67	3,8	500	10320
905	525,00	0,56	3,3	500	10320
793	613,33	0,46	2,9	500	10320
807	700,00	0,41	2,5	500	10320
638	766,67	0,32	2,3	500	10320
642	875,00	0,29	2,0	500	10320

IHW040+NMRV-P090

Mn ₂ [Nm]	i	Pn ₁ [kW]	n ₂ [rpm]	Fr1 [N]	Fr2 [N]
409	23,29	3,10	60,1	300	4343
460	31,05	2,65	45,1	400	4780
492	42,00	2,12	33,3	400	4780
518	46,58	2,07	30,1	400	5472
573	63,00	1,72	22,2	400	5472
444	77,63	1,15	18,0	400	6487
549	84,00	1,29	16,7	400	6022
556	93,16	1,27	15,0	400	6894
601	110,00	1,09	12,7	400	8174
615	126,00	1,07	11,1	400	6894
591	137,50	0,89	10,2	400	8180
468	155,26	0,72	9,0	400	8174
673	165,00	0,91	8,5	400	8180
418	186,32	0,57	7,5	400	8180
614	220,00	0,67	6,4	400	8180
469	252,00	0,50	5,6	400	8180
573	275,00	0,53	5,1	400	8180
552	304,55	0,47	4,6	400	8180
503	330,00	0,42	4,2	400	8180
612	383,33	0,42	3,6	400	8180
624	437,50	0,38	3,2	400	8180
534	460,00	0,33	3,0	400	8180
544	525,00	0,29	2,7	400	8180
426	613,33	0,22	2,3	400	8180
432	700,00	0,19	2,0	400	8180
351	766,67	0,16	1,8	400	8180
354	875,00	0,14	1,6	400	8180

IHW040+NMRV-P110

Mn ₂ [Nm]	i	Pn ₁ [kW]	n ₂ [rpm]	Fr1 [N]	Fr2 [N]
411	23,29	3,08	60,1	300	5488
535	31,05	3,08	45,1	300	6040
492	42,00	2,12	33,3	500	6040
780	46,58	3,07	30,1	300	6914
783	62,11	2,37	22,5	500	7610
829	77,63	2,06	18,0	500	8198
930	84,00	2,12	16,7	500	7610
917	93,16	2,07	15,0	500	8711
1014	105,00	1,90	13,3	500	8198
1109	126,00	1,91	11,1	500	8711
938	137,50	1,36	10,2	500	10320

IHW040+NMRV-P110

Mn_2 [Nm]	i	Pn_1 [kW]	n_2 [rpm]	Fr_1 [N]	Fr_2 [N]
828	155,26	1,22	9,0	500	10320
1016	168,00	1,35	8,3	500	9588
739	186,32	0,95	7,5	500	10320
1115	220,00	1,16	6,4	500	10320
836	252,00	0,83	5,6	500	10320
1029	275,00	0,90	5,1	500	10320
978	304,55	0,78	4,6	500	10320
900	330,00	0,70	4,2	500	10320
937	383,33	0,60	3,6	500	10320
750	440,00	0,48	3,2	500	10320
959	460,00	0,55	3,0	500	10320
905	525,00	0,46	2,7	500	10320
793	613,33	0,37	2,3	500	10320
807	700,00	0,33	2,0	500	10320
638	766,67	0,26	1,8	500	10320
642	875,00	0,23	1,6	500	10320

IHW040+NMRV-P090

Mn ₂ [Nm]	i	Pn ₁ [kW]	n ₂ [rpm]	Fr1 [N]	Fr2 [N]
409	23,29	2,54	49,0	300	4343
460	31,05	2,18	36,7	400	4780
492	42,00	1,74	27,1	400	6487
518	46,58	1,71	24,5	400	5472
573	63,00	1,42	18,1	400	7426
444	77,63	0,95	14,7	400	6487
549	84,00	1,06	13,6	400	8174
556	93,16	1,05	12,2	400	6894
601	110,00	0,90	10,4	400	8174
615	126,00	0,88	9,1	400	8180
591	137,50	0,73	8,3	400	8180
468	155,26	0,60	7,3	400	8174
673	165,00	0,75	6,9	400	8180
418	186,32	0,48	6,1	400	8180
614	220,00	0,55	5,2	400	8180
469	252,00	0,41	4,5	400	8180
573	275,00	0,44	4,2	400	8180
552	304,55	0,39	3,7	400	8180
503	330,00	0,35	3,5	400	8180
612	383,33	0,34	3,0	400	8180
624	437,50	0,31	2,6	400	8180
534	460,00	0,27	2,5	400	8180
544	525,00	0,24	2,2	400	8180
426	613,33	0,18	1,9	400	8180
432	700,00	0,16	1,6	400	8180
351	766,67	0,13	1,5	400	8180
354	875,00	0,12	1,3	400	8180

IHW040+NMRV-P110

Mn ₂ [Nm]	i	Pn ₁ [kW]	n ₂ [rpm]	Fr1 [N]	Fr2 [N]
411	23,29	2,54	49,0	300	5488
535	31,05	2,53	36,7	300	6040
492	42,00	1,74	27,1	500	8198
780	46,58	2,54	24,5	300	6914
783	62,11	1,96	18,4	500	7610
829	77,63	1,70	14,7	500	8198
930	84,00	1,75	13,6	500	10320
917	93,16	1,72	12,2	500	8711
1014	105,00	1,56	10,9	500	10320
1109	126,00	1,58	9,1	500	10320
938	137,50	1,12	8,3	500	10320

IHW040+NMRV-P110

Mn_2 [Nm]	i	Pn_1 [kW]	n2 [rpm]	Fr1 [N]	Fr2 [N]
828	155,26	1,01	7,3	500	10320
1016	168,00	1,12	6,8	500	10320
739	186,32	0,80	6,1	500	10320
1115	220,00	0,96	5,2	500	10320
836	252,00	0,69	4,5	500	10320
1029	275,00	0,74	4,2	500	10320
978	304,55	0,64	3,7	500	10320
900	330,00	0,58	3,5	500	10320
937	383,33	0,49	3,0	500	10320
750	440,00	0,39	2,6	500	10320
959	460,00	0,45	2,5	500	10320
905	525,00	0,37	2,2	500	10320
793	613,33	0,31	1,9	500	10320
807	700,00	0,27	1,6	500	10320
638	766,67	0,22	1,5	500	10320
642	875,00	0,19	1,3	500	10320

IHW040+NMRV-P090

Mn ₂ [Nm]	i	Pn ₁ [kW]	n ₂ [rpm]	Fr1 [N]	Fr2 [N]
409	23,29	2,02	38,6	300	5894
460	31,05	1,74	29,0	400	6487
492	42,00	1,39	21,4	400	6487
518	46,58	1,36	19,3	400	7426
573	63,00	1,13	14,3	400	7426
444	77,63	0,76	11,6	400	8180
549	84,00	0,84	10,7	400	8174
556	93,16	0,85	9,7	400	8180
601	110,00	0,71	8,2	400	8174
615	126,00	0,71	7,1	400	8180
591	137,50	0,58	6,5	400	8180
468	155,26	0,49	5,8	400	8180
673	165,00	0,60	5,5	400	8180
418	186,32	0,39	4,8	400	8180
614	220,00	0,44	4,1	400	8180
469	252,00	0,33	3,6	400	8180
573	275,00	0,35	3,3	400	8180
552	304,55	0,31	3,0	400	8180
503	330,00	0,28	2,7	400	8180
612	383,33	0,28	2,4	400	8180
624	437,50	0,25	2,1	400	8180
534	460,00	0,22	2,0	400	8180
544	525,00	0,19	1,7	400	8180
426	613,33	0,14	1,5	400	8180
432	700,00	0,13	1,3	400	8180
351	766,67	0,11	1,2	400	8180
354	875,00	0,09	1,0	400	8180

IHW040+NMRV-P110

Mn ₂ [Nm]	i	Pn ₁ [kW]	n ₂ [rpm]	Fr1 [N]	Fr2 [N]
411	23,29	2,02	38,6	300	7448
535	31,05	2,02	29,0	300	8198
492	42,00	1,39	21,4	500	8198
780	46,58	2,03	19,3	300	9384
783	62,11	1,57	14,5	500	10320
829	77,63	1,36	11,6	500	10320
930	84,00	1,39	10,7	500	10320
917	93,16	1,39	9,7	500	10320
1014	105,00	1,25	8,6	500	10320
1109	126,00	1,27	7,1	500	10320
938	137,50	0,89	6,5	500	10320

IHW040+NMRV-P110

Mn_2 [Nm]	i	Pn_1 [kW]	n_2 [rpm]	Fr_1 [N]	Fr_2 [N]
828	155,26	0,82	5,8	500	10320
1016	168,00	0,90	5,4	500	10320
739	186,32	0,64	4,8	500	10320
1115	220,00	0,77	4,1	500	10320
836	252,00	0,55	3,6	500	10320
1029	275,00	0,59	3,3	500	10320
978	304,55	0,51	3,0	500	10320
900	330,00	0,46	2,7	500	10320
937	383,33	0,39	2,4	500	10320
750	440,00	0,32	2,0	500	10320
959	460,00	0,36	2,0	500	10320
905	525,00	0,30	1,7	500	10320
793	613,33	0,24	1,5	500	10320
807	700,00	0,22	1,3	500	10320
638	766,67	0,17	1,2	500	10320
642	875,00	0,15	1,0	500	10320

ATTENTION!

The revised data and information, shown in this technical catalogue, replaces the data of the previous editions. Old data is now obsolete. All technical data, dimensions, weights in this catalogue are subject to changes without warning. Illustrations are not binding. You can find the above mentioned data and information on our site www.motovario.com; please periodically consult the technical documentation on the web site to be always updated about possible modifications of performances and characteristics of the product.

All supplies effected by MOTOVARIO are governed exclusively by the general terms of sale that you can find on our website:

<http://www.motovario.com/eng/corporate/sales-conditions>

